

Audi of America
A6 3.0T Sedan and Avant Technical Specifications
2009 Model Year



Technical Specifications		2009 Audi A6 3.0 TFSI	
ENGINE:			
Type	V6, supercharged, spark-ignition direct injection		
Arrangement	Front mounted, longitudinal		
Bore	3.33 in.	84.5 mm	
Stroke	3.50 in.	89 mm	
Displacement	2995 cc		
Compression ratio	10.5:1		
Fuel requirement	Premium unleaded (91 AKI)		
Horsepower (SAE)	300 hp	@	5100-6800 rpm
Max. Torque	310 lbs. ft.	@	2500-5100 rpm
ENGINE DESIGN:			
Cylinder block	Aluminium alloy		
Cylinder head	Aluminium alloy		
Valve train / intake	DOHC, mechanical charger module with 2 intercoolers, 2 charge movement plaps, chain driven, continuous camshaft adjustment for the intake and exhaust valves, 4 valves per cylinder		
Firing order	1 - 4 - 3 - 6 - 2 - 5		
Fuel injection / Ignition system	fully electronic management with drive-by-wire throttle control, petrol direct injection, cylinder-selective lambda control mapped ignition with solid-state high-voltage distribution, manifold-pressure controlled system		
Emission system	two close-coupled ceramic main catalytic converters		
ELECTRICAL SYSTEM:			
Battery	12 volts	110 amp/hr	
Alternator	14 volts	180 amp	
DRIVETRAIN:			
Transmission	six-speed automatic with Tiptronic® and DSP (Dynamic Shift Program)		
Type	quattro Tiptronic		
	Automatic		
Gear ratios: 1st	4.171:1		
2nd	2.340:1		
3rd	1.521:1		
4th	1.143:1		
5th	0.867:1		
6th	0.691:1		
Reverse	3.403:1		
Final Drive	3.088:1		
Front Differential	Hypoid gear, electronically locking (EDL)		
Center Differential	Torque sensing differential providing automatic and variable front to rear power proportioning		
Rear Differential	Hypoid gear, electronically locking (EDL)		
STEERING:			
Type	vehicle speed-sensitive power rack and pinion		
Ratio	16.0:1		
Turns (lock-to-lock)	2.74		
Turning circle (curb-to-curb)	39.0 ft.	11.9 m	
SUSPENSION:			
Front	Four link, anti roll bar, twin-tube-gas-filled shock absorbers		
Rear	Trapezoidal-link, twin-tube-gas-filled shock absorbers		
BRAKES:			
	Electronic stability program (ESP) with anti-lock brake, electronic rear brake pressure proportioning, vacuum power assist, asbestos free linings, dual diagonal circuits		
Front, size and type	12.6 in.	321 mm	- Ventilated disc
Rear, size and type	11.9 in.	302 mm	- Solid disc

Audi of America
A6 3.0T Sedan and Avant Technical Specifications
2009 Model Year



Technical Specifications (continued)		2009 Audi A6 3.0 TFSI				
BODY:						
Material	galvanized steel (Hood and front fenders are aluminum)					
Corrosion protection	Multi-step anti-corrosion protection (12 year limited warranty against corrosion perforation)					
WARRANTY/MAINTENANCE:	4-Year/50,000 mile new vehicle limited warranty					
CAPACITIES:						
quattro sedan & avant						
Engine oil	6.9 qt.	6.5 liter				
Fuel tank	21.1 gal.	80 liter				
Cooling system	10.1 qt.	9.6 liter				
EXTERIOR DIMENSIONS:						
		quattro sedan		quattro Avant		
Wheelbase		111.9 in.	2843 mm	111.9 in.	2843 mm	
Track:	front / rear	63.5/63.7 in.	1612 / 1618	62.7 / 62.9 in.	1592/1598	
Overall length		193.5 in.	4916 mm	194.2 in.	4933 mm	
Overall width		79.2 in.	2012 mm	79.2 in.	2012 mm	
Height (unloaded)		57.4 in.	1459 mm	58.2 in.	1478 mm	
Ground clearance (loaded)		4.6 in.	118 mm	4.6 in.	118 mm	
Curb weight	auto.	4123 lbs.		4222 lbs.		
Drag coefficient		Cw = 0.29				
INTERIOR DIMENSIONS:						
Model		Sedan			Avant	
Seating Capacity		5			5	
Head room	front / rear	38.7 in.	982 mm	/	37.8 in.	959 mm
w/sunroof	front / rear	37.5 in.	952 mm	/	37.5 in.	960 mm
Shoulder room	front / rear	57.1 in.	1450 mm	/	55.9 in.	1421 mm
Leg room	front / rear	41.3 in.	1050 mm	/	36.9 in.	938 mm
Int. vol. (EPA)	front / rear	52.8 cu ft / 45.14 cu ft = total of 97.94 cu. ft.				
Int. vol. (EPA)	front / rear	51 cu ft / 45.19 cu ft = total of 96.19 cu. ft. (with sunroof)				
Luggage capacity (EPA)		15.9 cu. ft.				
		SAE certified interior cargo volume with rear seats folded down = 63.83 cu. Ft.				
PERFORMANCE:						
		quattro sedan		quattro Avant		
0-60 mph		5.9 sec.		6.1 sec.		
1/4 mile		sec.		sec.		
Top speed		Electronically limited to 130 mph (209 km/h) on all A6 models				
FUEL ECONOMY: EPA estimate						
		quattro sedan		quattro Avant		
City		18 mpg		18 mpg		
Highway		26 mpg		26 mpg		
Combined		21 mpg		21 mpg		

Audi A6

Dimensions

09/08

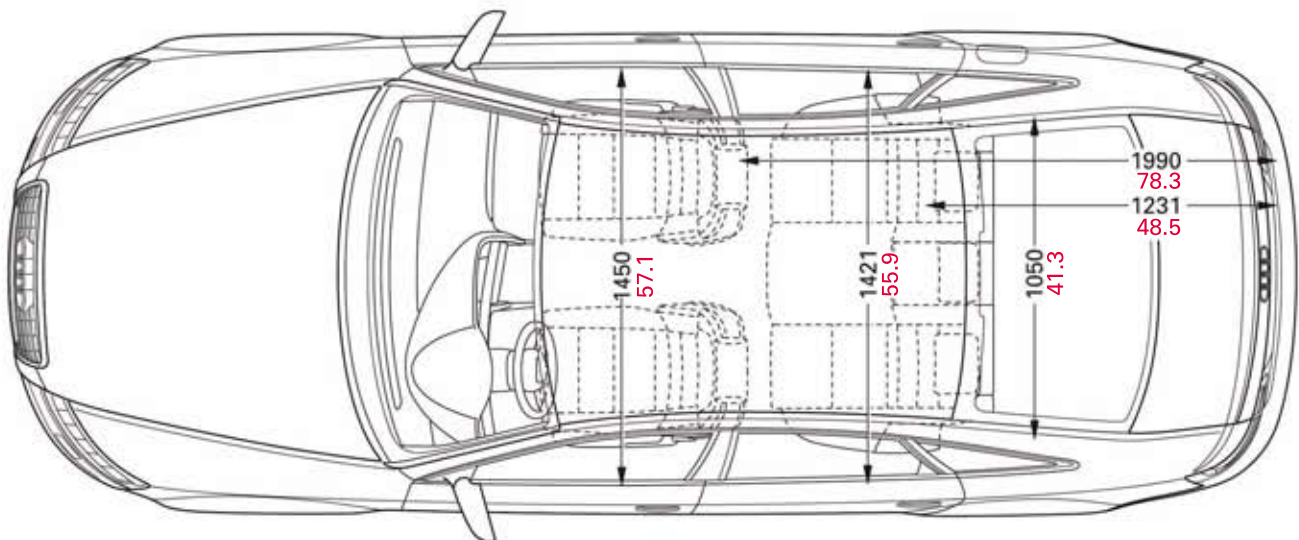
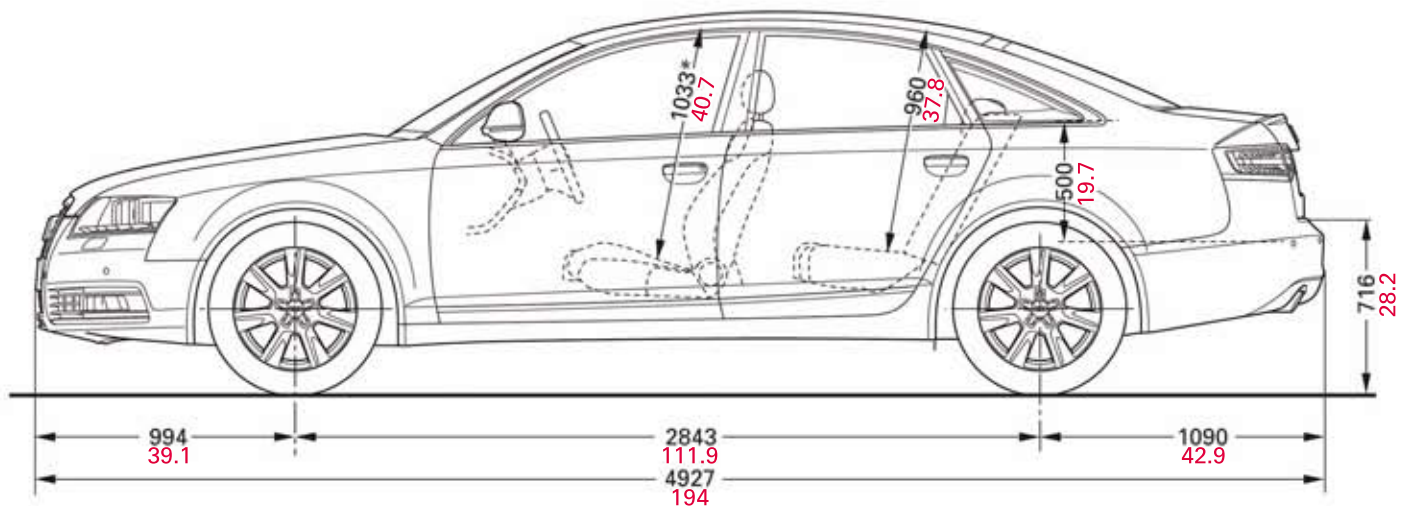
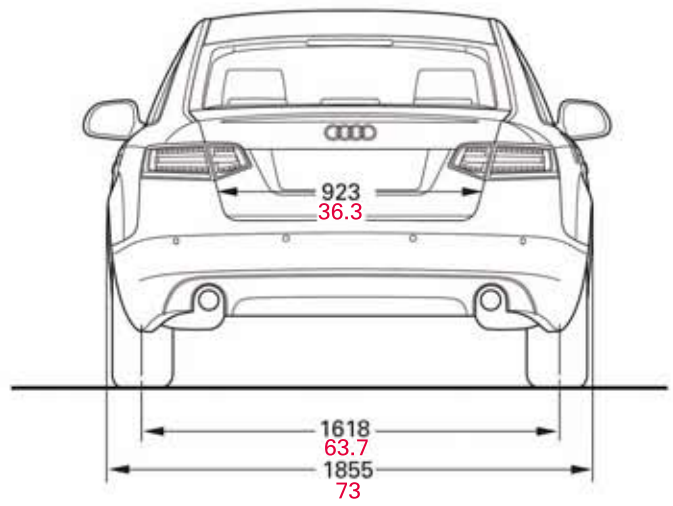
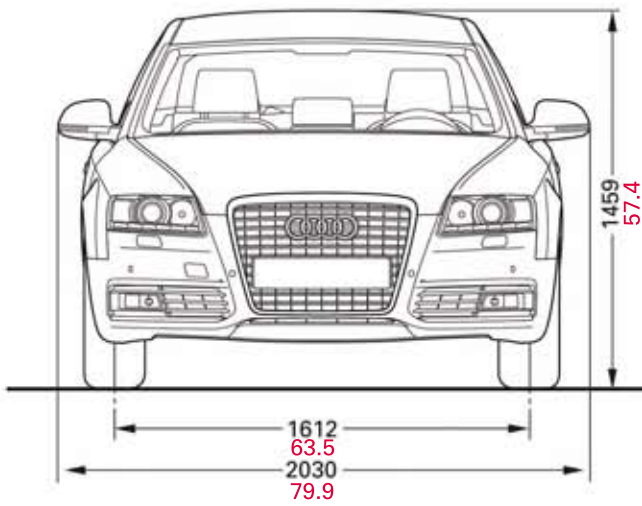

* maximum headroom

Dimensions in millimeters and inches

Dimensions of vehicle unloaded