

Audi of America
A6 3.2 Sedan Technical Specifications
2009 Model Year



Technical Specifications		2009 Audi A6 3.2 FSI	
ENGINE:			
Type	V6, spark-ignition direct injection		
Arrangement	Front mounted, longitudinal		
Bore	3.33 in.	84.5 mm	
Stroke	3.65 in.	92.8 mm	
Displacement	191 cu. in.	3123 cc	
Compression ratio	12.5:1		
Fuel requirement	Regular unleaded (87 AKI), Premium unleaded (91 AKI) recommended for maximum performance		
Horsepower (SAE)	255 hp	@	6500 rpm
Max. Torque	243 lbs. ft.	@	3250 rpm
ENGINE DESIGN:			
Cylinder block	Aluminium alloy		
Cylinder head	Aluminium alloy		
Valve train / intake	DOHC, chain driven, continuous camshaft adjustment for the intake and exhaust valves, 4 valves per cylinder		
Firing order	1 - 4 - 3 - 6 - 2 - 5		
Fuel injection / Ignition system	fully electronic management with drive-by-wire throttle control, petrol direct injection, cylinder-selective lambda control mapped ignition with solid-state high-voltage distribution, manifold-pressure controlled system		
Emission system	two close-coupled ceramic main catalytic converters		
ELECTRICAL SYSTEM:			
Battery	12 volts	110 amp/hr	
Alternator	14 volts	180 amp	
DRIVETRAIN:			
Transmission	multitronic CVT		
Type	FrontTrak multitronic CVT		
	Automatic		
Gear ratios:	1st	2.510:1	
	2nd	1.476:1	
	3rd	1.095:1	
	4th	0.820:1	
	5th	0.636:1	
	6th	0.500:1	
	7th	0.382:1	
	Reverse	2.510:1	
	Final Drive	4.877:1	
Front Differential	Hypoid gear, electronically locking (EDL)		
Center Differential			
Rear Differential			
STEERING:			
Type	vehicle speed-sensitive power rack and pinion		
Ratio	16.1:1		
Turns (lock-to-lock)	2.74		
Turning circle (curb-to-curb)	39.0 ft.	11.9 m	
SUSPENSION:			
Front	Four link, anti roll bar, twin-tube-gas-filled shock absorbers		
Rear	Trapezoidal-link, twin-tube-gas-filled shock absorbers		
BRAKES:			
	Electronic stability program (ESP 8) with anti-lock brake, electronic rear brake pressure proportioning, vacuum power assist, asbestos free linings, dual diagonal circuits		
Front, size and type	12.6 in.	321 mm	- Ventilated disc
Rear, size and type	11.9 in.	302 mm	- Solid disc

Audi of America
A6 3.2 Sedan Technical Specifications
2009 Model Year



Technical Specifications (continued)		2009 Audi A6 3.2 FSI	
BODY:			
Material	galvanized steel (Hood and front fenders are aluminum)		
Corrosion protection	Multi-step anti-corrosion protection (12 year limited warranty against corrosion perforation)		
WARRANTY/MAINTENANCE:			
		4-Year/50,000 mile new vehicle limited warranty	
		12-Month/5,000 mile (whichever occurs first) NO CHARGE first scheduled maintenance	
CAPACITIES:			
FrontTrak multitronic CVT			
Engine oil	6.9 qt.	6.5 liter	
Fuel tank	21.1 gal.	80 liter	
Cooling system	10.1 qt.	9.6 liter	
EXTERIOR DIMENSIONS:			
FrontTrak multitronic CVT			
Wheelbase	111.9 in.	2843 mm	
Track: front / rear	63.5 / 63.7 in.	1612 / 1618	
Overall length	193.5 in.	4916 mm	
Overall width	79.2 in.	2012 mm	
Height (unloaded)	57.4 in.	1459 mm	
Ground clearance (loaded)	4.6 in.	118 mm	
Curb weight man. / auto.	3847 lbs.		
Drag coefficient	Cw = 0.29		
INTERIOR DIMENSIONS:			
Sedan			
Model			
Seating Capacity	5		
Head room front / rear	38.7 in.	982 mm	37.8 in. 959 mm
w/sunroof front / rear	37.5 in.	952 mm	37.8 in. 960 mm
Shoulder room front / rear	57.1 in.	1450 mm	55.9 in. 1421 mm
Leg room front / rear	41.3 in.	1050 mm	36.9 in. 938 mm
Int. vol. (EPA) front / rear	52.8 cu ft / 45.14 cu ft = total of 97.94 cu. ft.		
Int. vol. (EPA) front / rear	51 cu ft / 45.19 cu ft = total of 96.19 cu. ft. (with sunroof)		
Luggage capacity (EPA)	15.9 cu. ft.		
PERFORMANCE:			
FrontTrak multitronic CVT			
0-50 mph (0-80kmh)	5.3		
0-60 mph (0-100 km/h)	6.9		
1/4 mile	15.2		
Top speed	Electronically limited to 130 mph (209 km/h) on all A6 models		
FUEL ECONOMY:			
		EPA estimate	2008 EPA figures
FrontTrak multitronic CVT			
City	18	mpg	
Highway	27	mpg	
Combined	21	mpg	

Audi A6

Dimensions

09/08

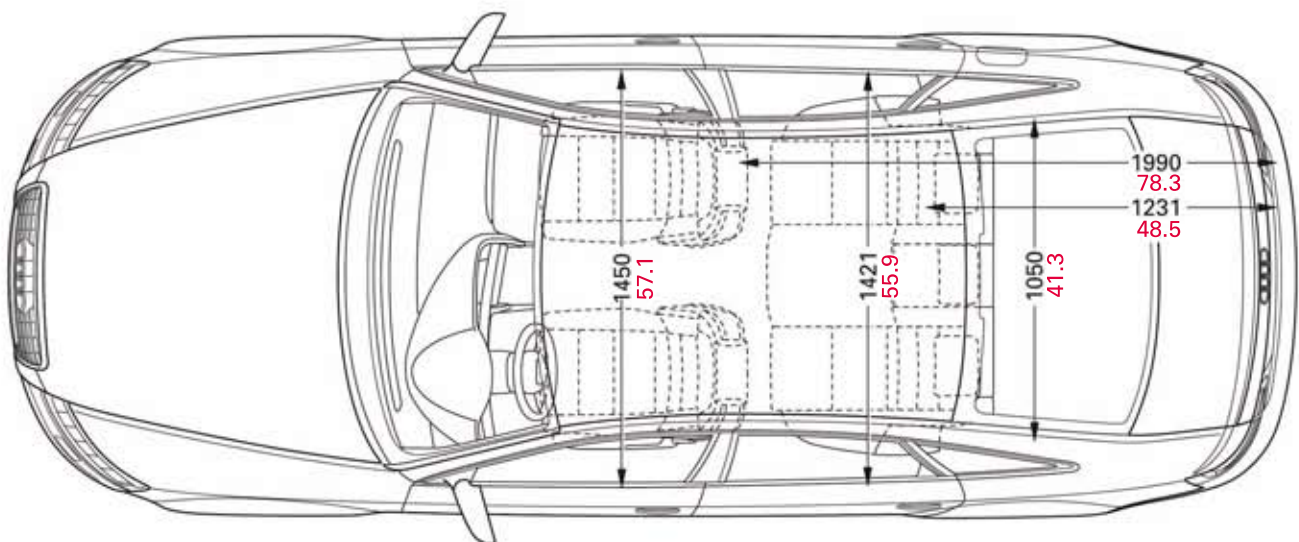
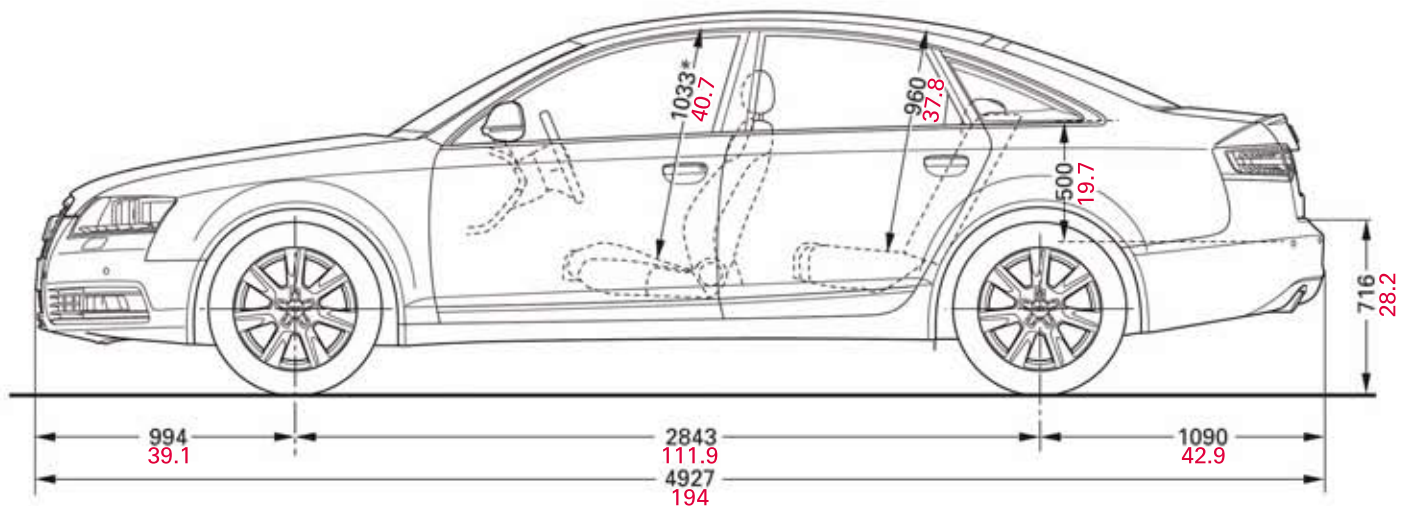
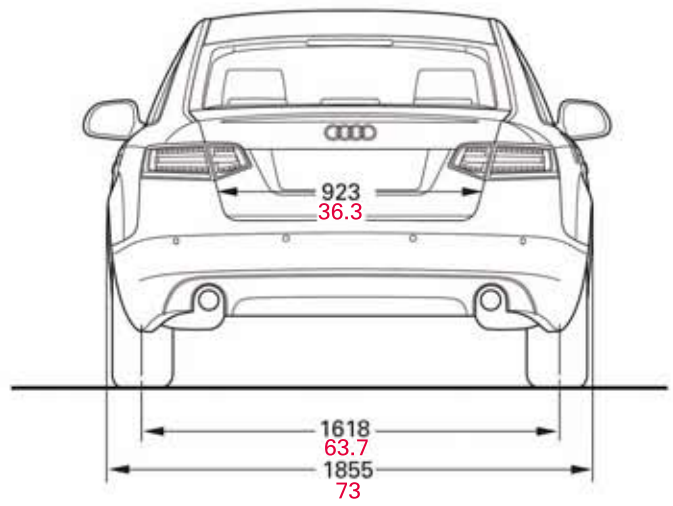
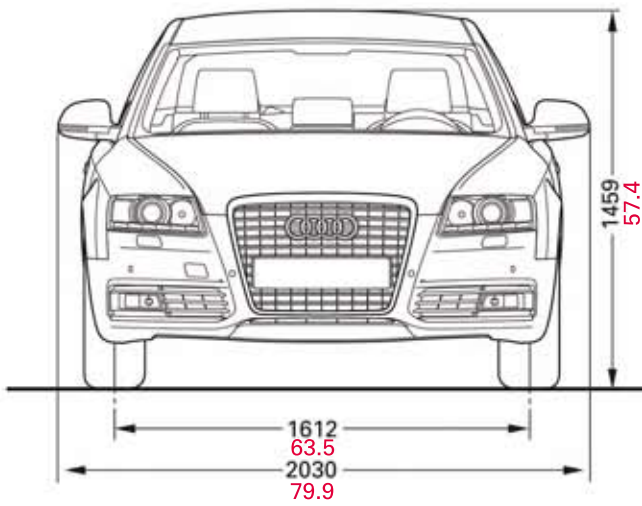

* maximum headroom

Dimensions in millimeters and inches

Dimensions of vehicle unloaded