

Audi of America  
A6 4.2 Sedan Technical Specifications  
2009 Model Year



Technical Specifications		2009 Audi A6 4.2 FSI quattro sedan	
<b>ENGINE:</b>			
Type	V8 spark-ignition direct injection		
Arrangement	Front mounted, longitudinal		
Bore	3.33 in.	84.5 mm	
Stroke	3.65 in.	92.8 mm	
Displacement	254 cu. in.	4163 cc	
Compression ratio	12.5:1		
Fuel requirement	min. Premium unleaded (91 AKI), Premium unleaded plus (95 AKI) recommended for maximum performance		
Horsepower (SAE)	350 hp	6800 rpm	
Max. Torque	325 lbs. ft.	3500 rpm	
<b>ENGINE DESIGN:</b>			
Cylinder block	Aluminium alloy		
Cylinder head	Aluminium alloy		
Valve train / intake	DOHC, chain driven, continuous camshaft adjustment for intake and exhaust valves 4 valve		
Firing order	1 - 5 - 4 - 8 - 6 - 3 - 7 - 2		
Fuel injection / Ignition system	fully electronic sequential injection, coordinated torque control, hot-film air mass measurement, drive-by-wire throttle control, mapped ignition with solid-state high-voltage distribution, adaptive lambda control		
Emission system	two close-coupled ceramic main catalytic converters, secondary air system		
<b>ELECTRICAL SYSTEM:</b>			
Battery	12 volts	110 amp/hr	
Alternator	14 volts	190 amp	
<b>DRIVETRAIN:</b>			
Transmission	six-speed automatic with Tiptronic® and automatic shift lock		
Type	Automatic		
Gear ratios:	1st	4.171:1	
	2nd	2.340:1	
	3rd	1.521:1	
	4th	1.143:1	
	5th	0.867:1	
	6th	0.691:1	
	Reverse	3.403:1	
	Final Drive	3.309:1	
Front Differential	Hypoid gear, electronically locking (EDL)		
Center Differential	Torque sensing differential providing automatic and variable front to rear power proportioning		
Rear Differential	Hypoid gear, electronically locking (EDL)		
<b>STEERING:</b>			
Type	vehicle speed-sensitive power rack and pinion		
Ratio	14.6:1		
Turns (lock-to-lock)	2.49		
Turning circle (curb-to-curb)	39.0 ft.	11.9 m	
<b>SUSPENSION:</b>			
Front	Four link, anti roll bar, twin-tube-gas-filled shock absorbers		
Rear	Trapezoidal-link, twin-tube-gas-filled shock absorbers		
<b>BRAKES:</b>			
	Electronic stability program (ESP 8) with anti-lock brake, electronic rear brake pressure proportioning, vacuum power assist, asbestos free linings, dual diagonal circuits		
Front, size and type	13.7 in.	347 mm	- Ventilated disc
Rear, size and type	13.0 in.	330 mm	- Ventilated disc

Audi of America  
A6 4.2 Sedan Technical Specifications  
2009 Model Year



Technical Specifications (continued)		2009 Audi A6 4.2 FSI quattro sedan	
<b>BODY:</b>			
Material	galvanized steel		
Corrosion protection	Multi-step anti-corrosion protection (12 year limited warranty against corrosion perforation)		
<b>WARRANTY/MAINTENANCE:</b>			
4-Year/50,000 mile new vehicle limited warranty			
12-Month/5,000 mile (whichever occurs first) NO CHARGE first scheduled maintenance			
<b>CAPACITIES:</b>			
Engine oil	8.9 qt.	8.4 liter	
Fuel tank	21.1 gal.	80 liter	
Cooling system	12.7 qt.	12.0 liter	
<b>EXTERIOR DIMENSIONS:</b>			
Wheelbase	111.9 in.	2843 mm	
Track: front / rear	63.5 / 64 in	1612/1618	
Overall length	193.5 in.	4916 mm	
Overall width	79.2 in.	2012 mm	
Height (unloaded)	57.4 in.	1459 mm	
Ground clearance (loaded)	4.6 in.	118 mm	
Curb weight	4211 lbs.		
Drag coefficient	Cw = 0.29		
<b>INTERIOR DIMENSIONS:</b>			
Seating Capacity	5		
Head room front / rear	38.7 in.	982 mm	/ 37.8 in. 959 mm
w/sunroof front / rear	37.5 in.	952 mm	/ 37.8 in. 960 mm
Shoulder room front / rear	57.1 in.	1450 mm	/ 55.9 in. 1421 mm
Leg room front / rear	41.3 in.	1050 mm	/ 36.9 in. 938 mm
Int. vol. (EPA) front / rear	52.8 cu. ft.	/	45.14 cu. ft. = total of 97.94 cu. ft
Luggage capacity (EPA)	15.9 cu. ft.		
<b>PERFORMANCE:</b>			
0-50 mph (0-80kmh)	4.4 sec.		
0-60 mph (0-100 km/h)	5.8 sec.		
1/4 mile	14.2 sec.		
Top speed	Top speed is electronically limited to 130 mph (209 km/h)		
<b>FUEL ECONOMY:</b> 2009 EPA estimates			
City	16 mpg		
Highway	23 mpg		
Combined	18 mpg		

# Audi A6

## Dimensions

09/08

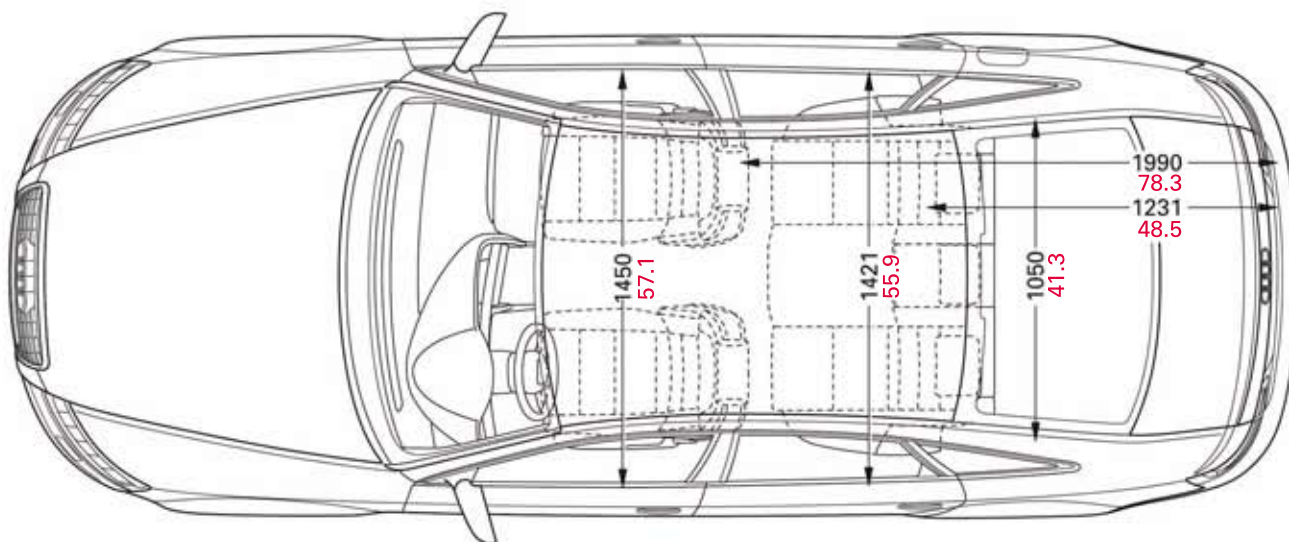
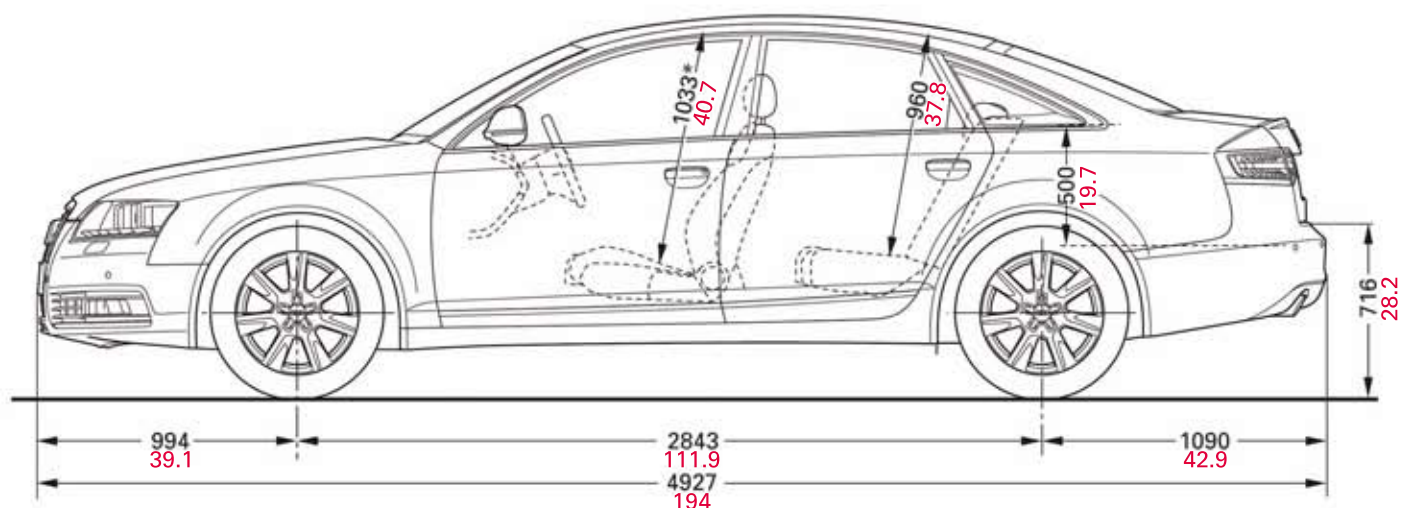
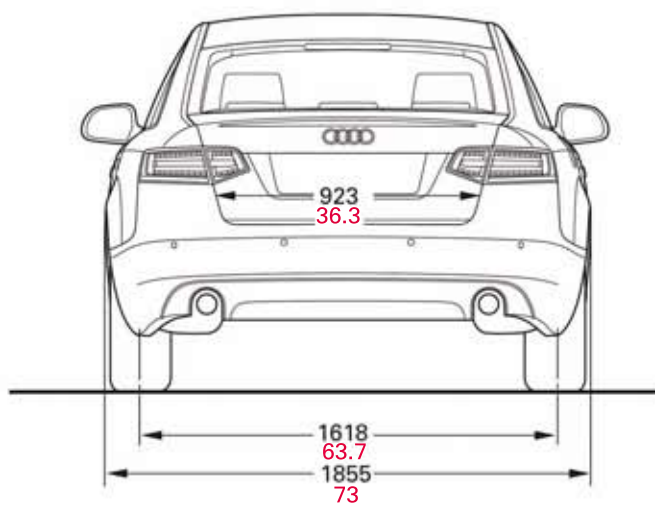
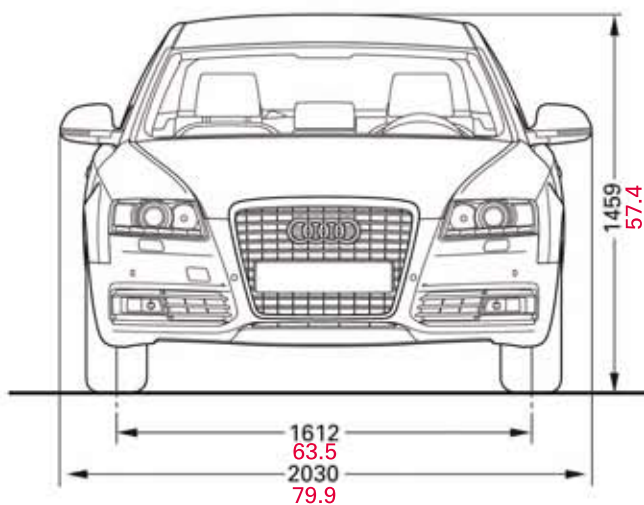

\* maximum headroom

Dimensions in millimeters and inches

Dimensions of vehicle unloaded