

## Audi > B3 Platform > 1994 - 1998

### Electrical Equipment

### 96 - Lights, Switches - Interior, Anti-theft

#### Ignition/starter switch, removing and installing

##### WARNING!

Airbags and related equipment (e.g. steering wheel) must only be disassembled, assembled and repaired by trained Audi Service Department personnel.

- ◆ Before working on any airbag, steering wheel or steering column components, always disconnect the battery.
- ◆ For m.y. 1994 and 1995 vehicles, disconnecting the battery alone will NOT prevent the accidental deployment of the airbag(s). Always disconnect the airbag power supply harness connector, and refer to the all airbag system Warnings and Cautions => Repair Manual, "Body Exterior, Interior" Repair Group 69.
- ◆ Make sure that no person is in the vehicle when connecting the battery Ground strap.

##### CAUTION!

Before disconnecting the battery, determine the correct coding for the anti-theft radio.

##### Notes:

- ▶ Ignition/starter switch can be removed and installed without removing the steering column.
- ▶ Ignition/starter switch terminal identification => page [96-14](#).
- Where applicable (m.y. 1994 and 1995), disconnect airbag power supply connector => Repair Manual, Body Exterior, Interior, Repair Group 69.
- Remove airbag => Repair Manual, Body Exterior, Interior, Repair Group 69.
- Remove steering wheel and steering column switches => Repair Manual, Suspension, Wheels, Brakes, Steering, Repair Group 48.

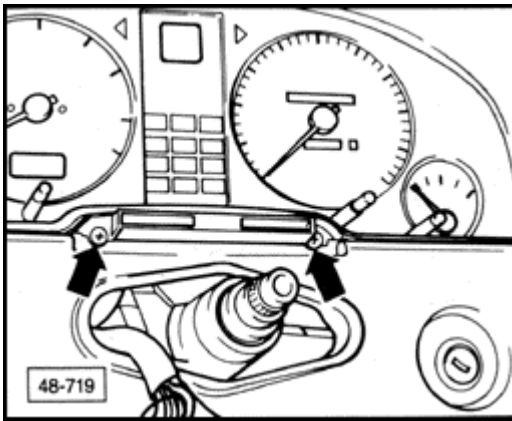

- Remove instrument cluster mounting screws (arrows).
- Place clean, soft towel or equivalent over exposed portion of steering column.
- Carefully tip back instrument cluster; be careful not to scratch face plate.
- Remove indicator lamps (with wiring harness) from instrument cluster as necessary.
- Unlock and disconnect instrument cluster harness connectors from behind ( => page [90-26](#)).
- Remove instrument cluster.

## Removing

### Note:

*The ignition/starter switch and lock housing is shown removed from instrument panel for illustration purposes only.*

- Disconnect ignition/starter switch connector.

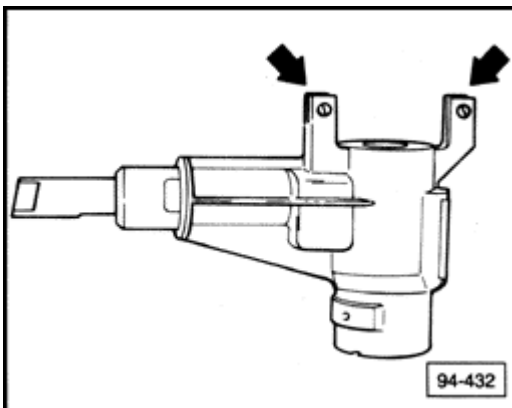

- Using a small screwdriver, remove safety paint from switch screws (arrows).
- Remove switch screws.

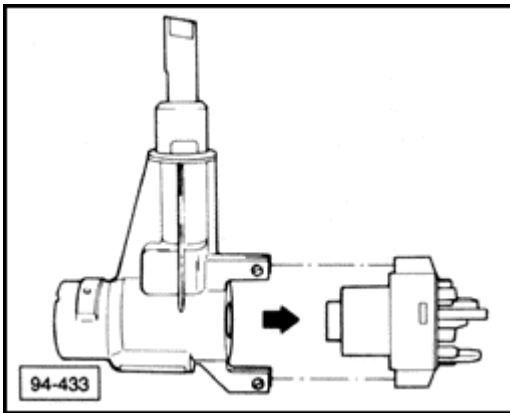

- Remove ignition/starter switch in direction shown (arrow).

### Installing

- Turn ignition/starter switch to off position.
- Insert switch into lock housing until seated.
- Apply thread-locking compound to screws, then install and tighten.

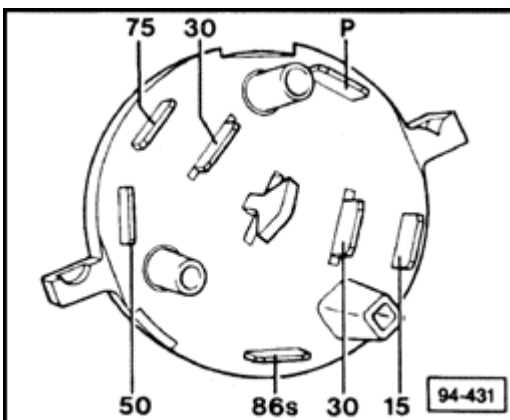

### Ignition/starter switch, terminal Identification

Wire routing and terminal connections => applicable wiring diagram.