

- Turn eccentric pulley counterclockwise using pin wrench 3387 (tab - **A** - of eccentric pulley must not be bent), until die T10008 can be pulled free of stress.

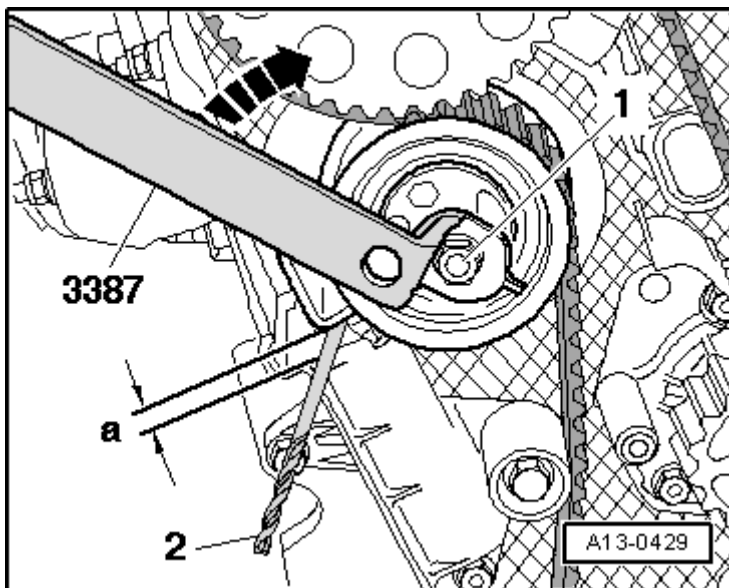

- Rotate eccentric pulley clockwise in - **direction of arrow** - until a drill bit - **2** - with dimension - **a** - can be pulled through between tensioning lever and housing of tensioning device.
- Specified dimension - **a** - : 8 mm
- Hold the tensioner roller in this position and tighten securing nut - **1** - with tensioner roller to 27 Nm.

Continuation for all vehicles