

Copyright VW AG

Technical Service Handbook (HST)

ElsaPro Job no.: 30744

DMS Repair Order number: **undefined**

VIN: [REDACTED]

Model year: **2014**

Model code: **4G251A**

Model description: **A6 Sal. qu. 3.0 V6228 A8**

Engine code: **CTUA**

Transmission code: **QCZ**

License plate:

Final drive code:

User name: [REDACTED]

Service advisor - name: [REDACTED] ([REDACTED])

Basic filtering of vehicle description

Brand	Model year	Model code	Engine code	Transmission code	Final drive code
A	2014	4G2% - A6	CTUA	%	%

Technical Service Bulletin

Transaction No.: **2044717/2**

87 Faint noise heard in cabin from air conditioning circuit

Release date: Sep 19, 2016

Condition

REVISION HISTORY		
Revision	Date	Purpose
2	-	Revised <i>Warranty</i> (Added 3.0 liter SRTs)
1	7/8/2016	Initial publication

A faint, high-pitched “whine” or high frequency buzzing noise is heard in the cabin when the air conditioning is set to “Low” and the fan speed is no higher than 2. The audio system must be off and there should be no other noises in the cabin, otherwise the noise may not be heard.

Technical Background

This noise can be created due to an anomaly in the acoustic characteristic in the refrigerant circuit under these specific settings (air conditioning set to “Low” and fan speed no higher than 2). There is no technical fault with the air conditioning system and no functional issue with the climate control system.

Production Solution

Not applicable. The refrigerant circuit architecture in the A6 and A7 models to which this bulletin applies is no longer in production.

Service

The noise symptom must be readily duplicated before any repair is performed. It is a good idea to ask the customer to duplicate the noise symptom for the technician to ensure that the repair resolves the customer’s specific complaint.

If the noise cannot be duplicated, do not perform any repair to the vehicle. If the noise can be duplicated consistently, proceed as follows:

- 1.

Perform a complete recovery and flush of the air conditioning refrigerant circuit (Figure 1 and Figure 2).

- Remove the air conditioning compressor, empty the compressor of the PAG oil completely, then reinstall it to the vehicle. The compressor does not need to be replaced.

⚠ Note:

It is imperative that the compressor mounting bolt centering sleeves be reinstalled with the compressor (Figure 3). Failure to reinstall these sleeves will result in compressor failure (as well as possible engine and/or ancillary component damage) in a short period of time. If any sleeves were misplaced during the removal and reinstallation process, new sleeves should be ordered and installed on the compressor housing before reassembly. Compressor or consequential component damage resulting from a failure to install the centering sleeves will not be accepted under warranty.

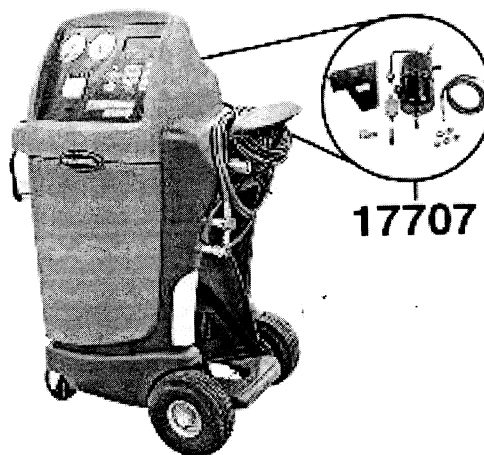

Figure 1. A/C flushing unit.

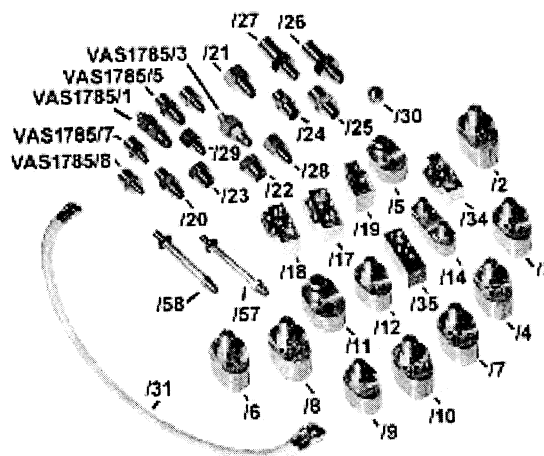

Figure 2. Flushing fitting set.

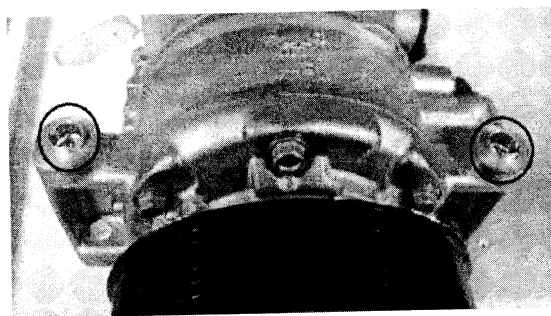

Figure 3. Mounting bolt centering sleeves on the air conditioning compressor housing.

- Replace the low side refrigerant line that connects the air conditioning compressor suction port to the hybrid refrigerant line to the expansion valve (Figure 4). Be certain to use new O-rings at these and all refrigerant circuit joints that are disconnected.

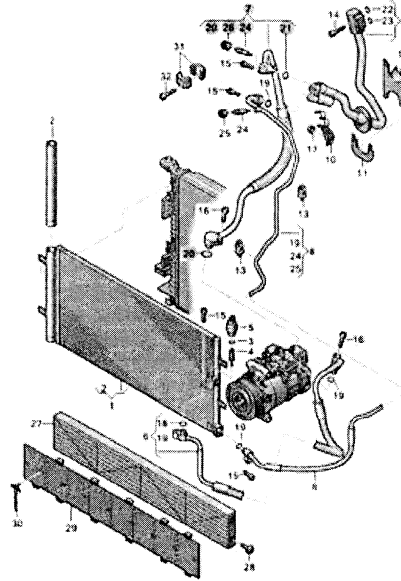

Figure 4. Low side line to be replaced.

4. Install the balance weight (part number 4G0513621A) to the line in the position shown in the illustration (Figure 5).

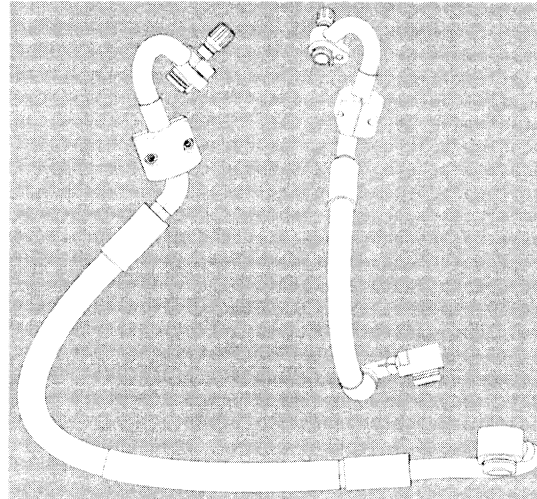

Figure 5. Balance weight position on low side line.

5. Recharge the refrigerant circuit with the specified volume. Replace the PAG oil completely with new PAG oil at the specified volume. Do not reuse the original oil extracted during the system flush. Use only the Denso PAG oil (part number G 052300A2) (Figure 6). Do not use a substitute.

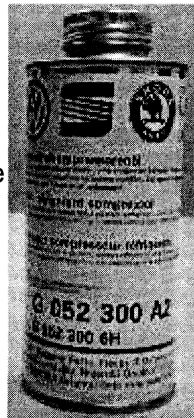

Figure 6. Denso PAG oil.

6. No additional air conditioning components need to be replaced. Recheck the air conditioning system under

the same settings used to duplicate the noise symptom and confirm that the noise issue is resolved.

Warranty

Claim Type:	<ul style="list-style-type: none"> • 110 up to 48 Months/50,000 Miles. • G10 for CPO covered vehicles – Verify Owner. • If vehicle is outside any warranty, this Technical Service Bulletin is informational only. 		
Service Number:	8745		
Damage Code:	0020		
Labor Operations:	Refrigerant drain+fill (if necessary)	8703 1700	60 TU
	Compressor remove+reinstall (for 3.0 liter A6 or A7)	8734 1908	160 TU
	Compressor remove+reinstall (for 2.0 liter A6)	8734 1913	70 TU
	Receiver-drier insert remove+reinstall (A6 with 2.0 TFSI)	8755 5500	40 TU
	-or-		
	Receiver-drier insert remove+reinstall (A6 and A7 with 3.0 liter engine)		
	Additional radiator front remove and reinstall	19 80 19 41	90 TU
	Charge air compressor remove and reinstall	21 14 19 41	160 TU
	Charge air coolers remove and reinstall	21 43 20 91	190 TU
	Receiver-drier insert remove+reinstall	87 55 55 50	10 TU
	Cover (plenum) remove+reinstall	8522 1900	20 TU
	Expansion valve remove+reinstall (Includes compressor/evaporator line remove and reinstall)	8770 1950	30 TU
	Crossmember remove+reinstall	5034 1900	90 TU
Air conditioner clean	8701 2950	110 TU	
Diagnostic Time:	GFF	No allowance	0 TU
	Road test prior to service procedure	0121 0002	10 TU
	Road test after service procedure	0121 0004	10 TU
	Technical diagnosis at dealer's discretion (Refer to Section 2.2.1.2 and Audi Warranty Online for DADP allowance details)		
Claim Comment:	As per TSB #2044717/2		

All warranty claims submitted for payment must be in accordance with the *Audi Warranty Policies and Procedures Manual*. Claims are subject to review or audit by Audi Warranty.

Required Parts and Tools

--	--	--

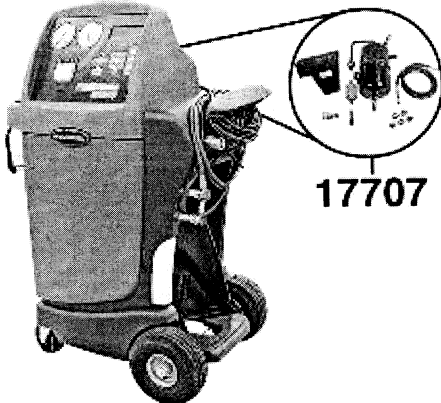
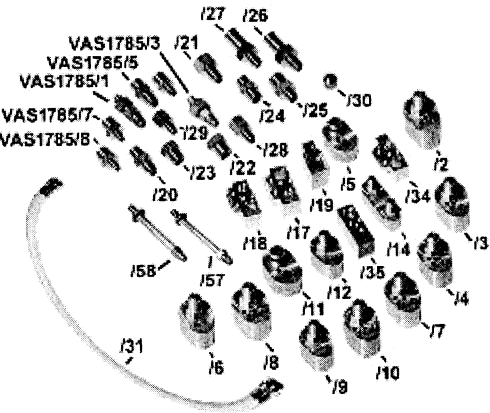
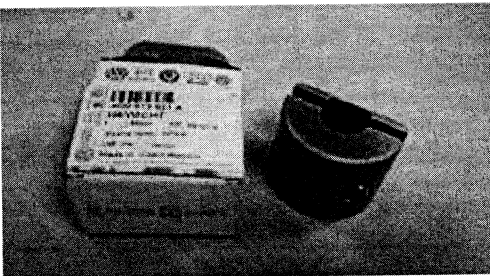
Part Number	Part Description	Quantity
ROB134APF	 <p>Robinair A/C Service Unit</p>	1
VAS 6338/1	 <p>Refrigerant Circuits Adapter Set</p>	1
<p>4G0260707X</p> <p>Use appropriate part number for the hose according to the VIN in ETKA</p>	<p>Air conditioner hose (Compressor to hybrid line)</p>	1
4G0513621A	 <p>Balance Weight</p>	1
G 052300A2		0.5

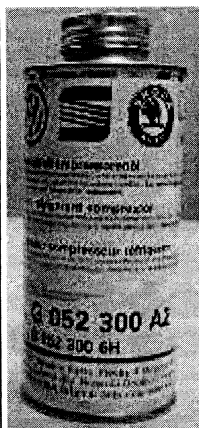

PAG oil for Denso Refrigerant Compressors

Additional Information

All parts and service references provided in this TSB (2044717) are subject to change and/or removal. Always check with your Parts Department and service manuals for the latest information.

©2016 Audi of America, Inc. All rights reserved. Information contained in this document is based on the latest information available at the time of printing and is subject to the copyright and other intellectual property rights of Audi of America, Inc., its affiliated companies and its licensors. All rights are reserved to make changes at any time without notice. No part of this document may be reproduced, stored in a retrieval system, or transmitted in any form or by any means, electronic, mechanical, photocopying, recording, or otherwise, nor may these materials be modified or reposted to other sites without the prior expressed written permission of the publisher.