

**Audi > C5 > 1998-2005**  
**Engine Mechanical**  
**15 - Valve train, servicing**

**Camshafts and camshaft adjusters, removing and installing**

**Special tools, testers and auxiliary items required**

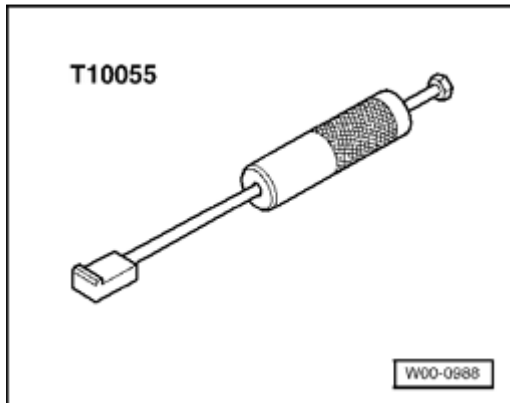

◆ extractor T10055

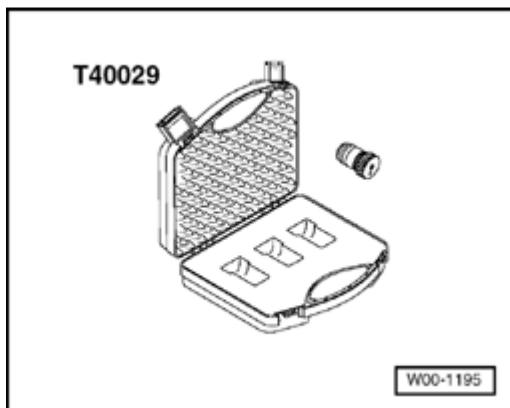

- ◆ locating pin T40029
- ◆ Drill with plastic brush attachment
- ◆ Protective glasses
- ◆ Sealants
- ◆ See Parts catalog

**Removing**

- Remove toothed belt ⇒ [Toothed belt, removing and installing](#) .
- Remove respective camshaft gears.
- Remove combination valve for Secondary Air Injection ⇒ [Left combination valve for secondary air injection, removing and installing](#) or ⇒ [Right combination valve for secondary air injection, removing and installing](#) .

### Right side cylinder head

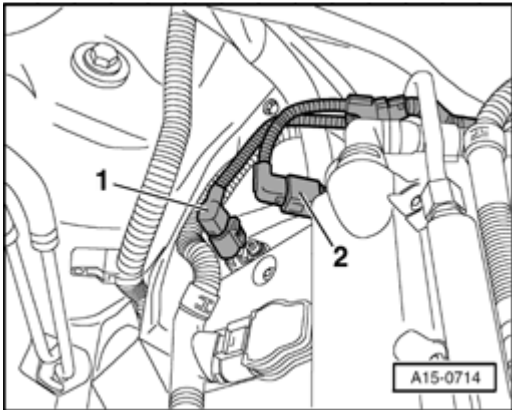

- Disconnect electrical harness connectors - 1 - and - 2 - at Camshaft Position (CMP) sensor G40 and Camshaft Position (CMP) sensor 3 G300 .

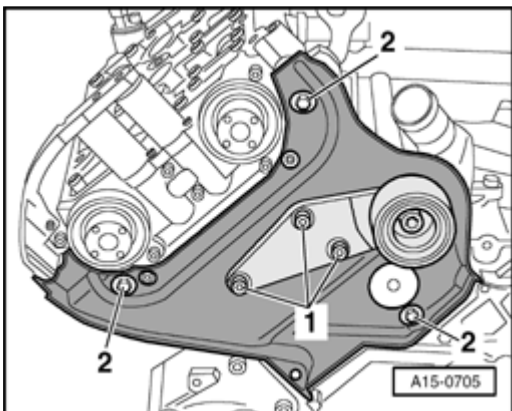

- Unscrew bolts - 1 - and remove bracket with idler roller.
- Unscrew bolts - 2 - and remove toothed belt guard at rear right.

### Left side cylinder head

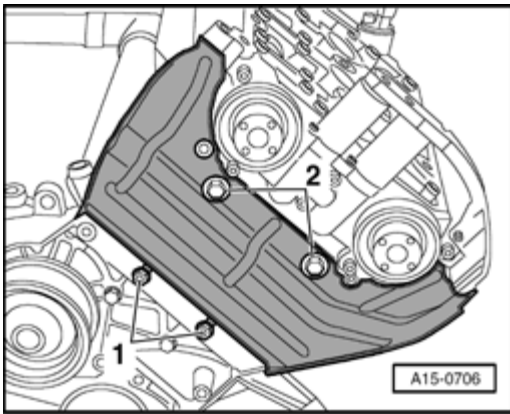

- Unscrew bolts - 1 - and - 2 - and remove toothed belt guard at rear left.

### All

- Remove camshaft adjuster gauge T40030 from camshafts.

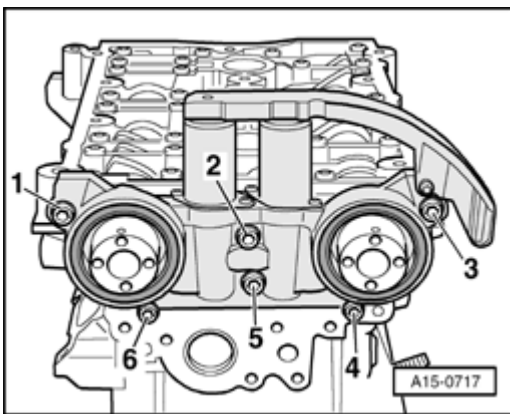

- Unscrew bolts - 1 to 6- and remove housing for camshaft adjustment valves.

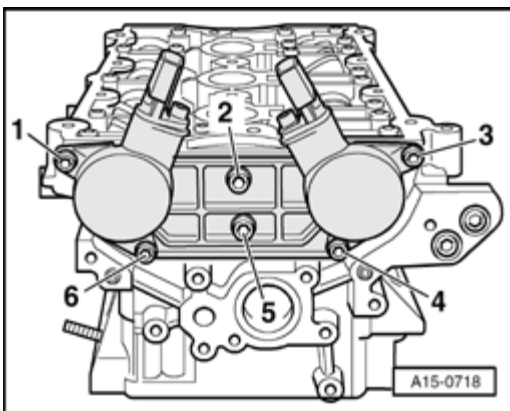

- Unscrew bolts - 1 to 6- and remove housing for Camshaft Position (CMP) sensor.

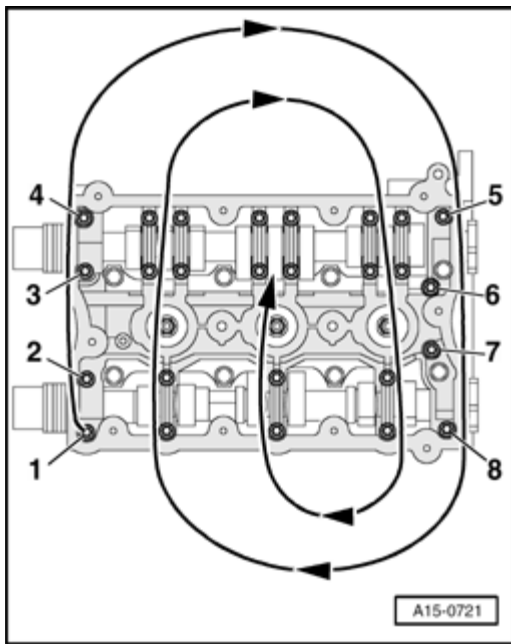

- Loosen bolts of guide frame in numbered sequence shown and follow arrows.

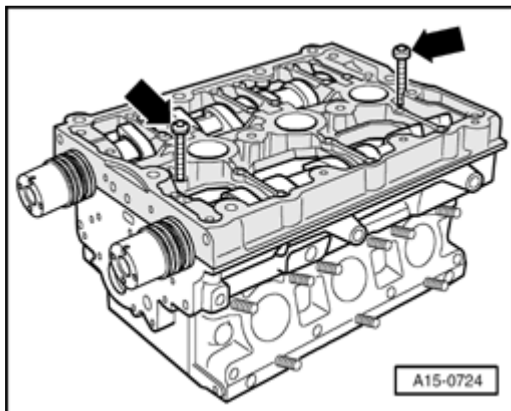

- Press off guide frame with M6 bolts (arrows).
- Carefully remove guide frame.

### **CAUTION!**

**Wear protective glasses.**

- Using rotating plastic brush, remove remaining sealant from cylinder head and guide frame.
- Clean sealing surfaces so they are free of oil and grease.

### **Installing**

**Note:**

- ◆ *Replace gaskets and O-rings.*
- ◆ Crankshaft aligned using locking pin T40026 .
- Oil camshaft journal surface.

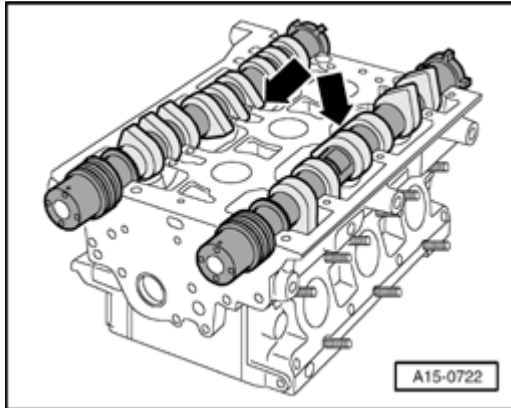
**Left side cylinder head**

- Insert camshaft into cylinder head as depicted in illustration.
- ◆ Cams at cylinder 5 point downward evenly (arrows).

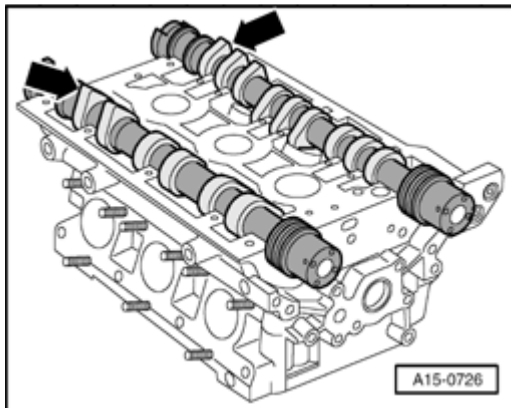
**Right side cylinder head**

- Insert camshaft into cylinder head as depicted in illustration.
- ◆ Cams at cylinder 3 point upward evenly (arrows).

**All**

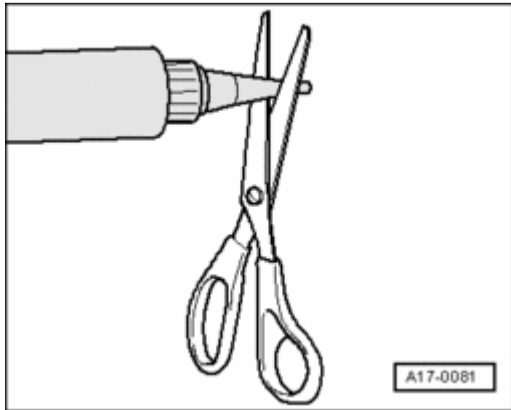

- Cut tube nozzle at front marking (jet diameter approx. 1 mm).

**Note:**

- \* Sealant bead must be applied according to exact specifications, otherwise excess sealant could get into the camshaft bearings.

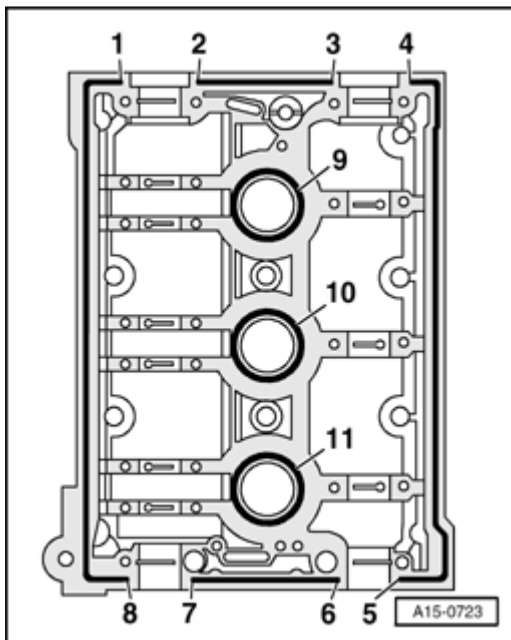

- Apply sealant to clean sealing surface of guide frame as depicted in illustration.

- \* Thickness of sealant bead: Approx. 1.2 mm
- \* Distance of sealant bead to the camshaft bearings at the specified locations - 1 to 8-: at least 5 mm
- \* In addition, for sealing surfaces around spark plug bores, obtain a sealant ring each, - 9 - to - 11 -

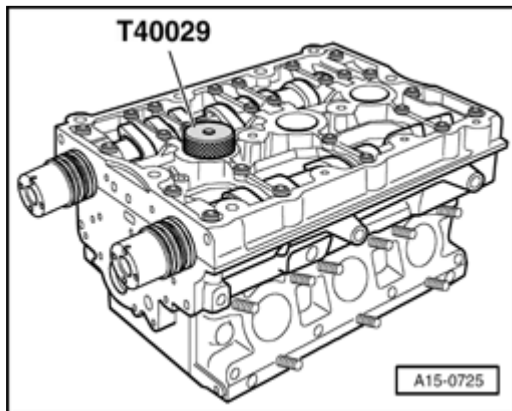

- Immediately set guide frame in place and align using locating pin T40029 .

**Note:**

- \* *Setting in place and tightening the guide frame should occur without interruptions, since the sealant starts to harden immediately.*
- \* *After installing guide frame, allow sealant to dry for approx. 30 minutes.*

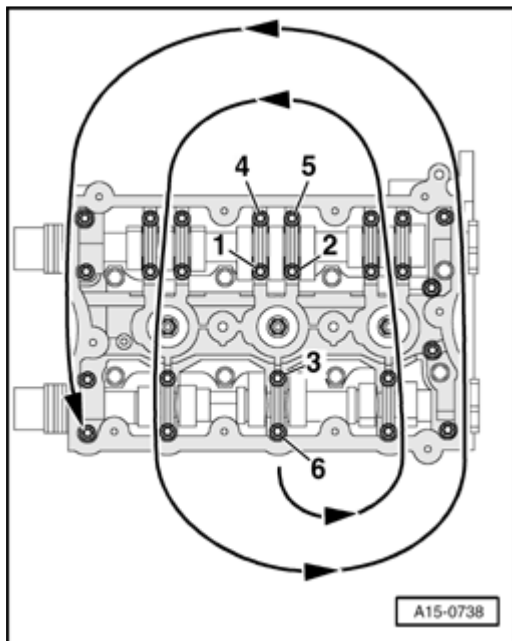

- Tighten bolts of guide frame in numbered sequence and follow arrows.

\* Guide frame must make full contact with cylinder head surface

- Tighten bolts of guide frame to final tightening torque (10 Nm).

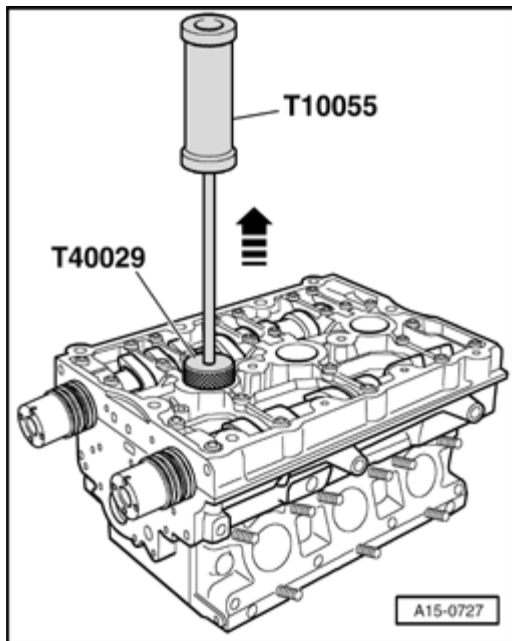

- Using extractor T10055 , remove locating pin T40029 from cylinder head.

### **Left side cylinder head**

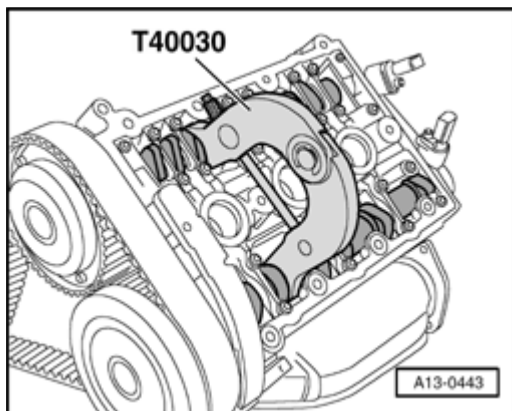

- Insert camshaft adjuster gauge T40030 at camshafts.
- Spread camshaft adjuster gauge T40030 with threaded shaft (tightening torque 10 Nm) until it is seated without axial play.

### **Right side cylinder head**

- Install camshaft gear of exhaust camshaft.



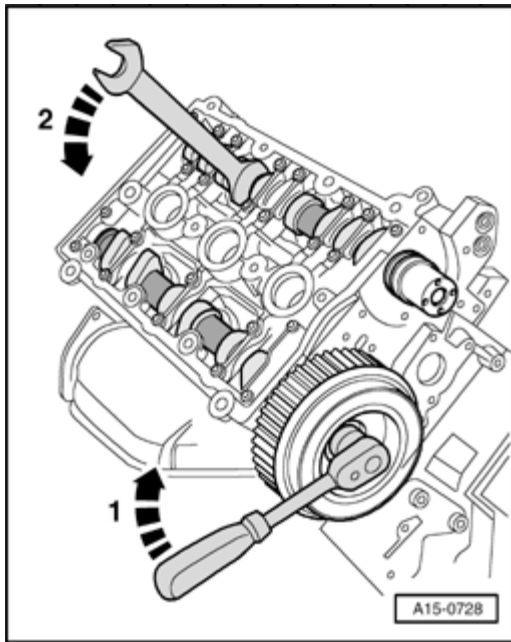

- In each case, turn exhaust camshaft (arrow - 1 - ) and intake camshaft (arrow - 2 - ) 30 ° in direction of arrow...

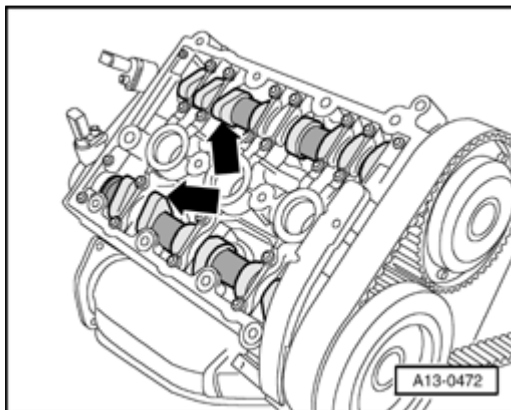

- ...until cams (arrows) of cylinder 3 at intake and exhaust camshafts are as shown in illustration.

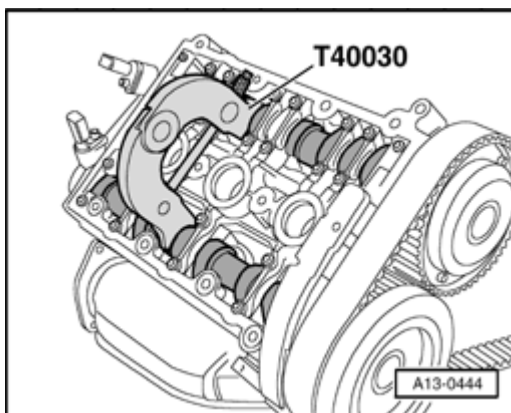

- Insert camshaft adjuster gauge T40030 at camshafts.
- Remove exhaust camshaft gear again.

## All

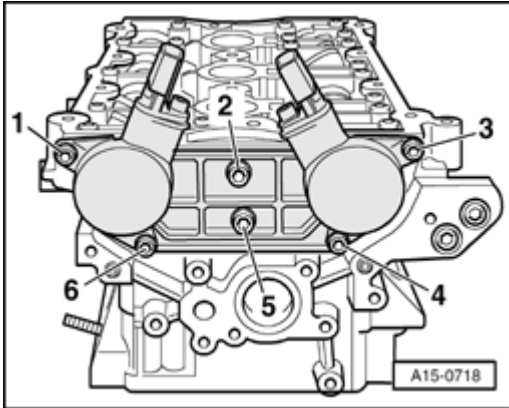

- Install Camshaft Position (CMP) sensor housing and tighten bolts -1 to 6-

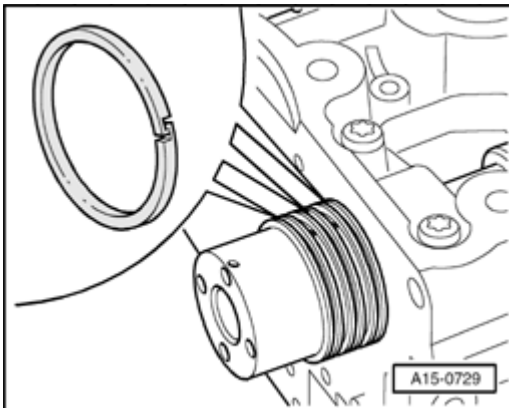

- Check whether piston rings are installed at camshafts and whether piston ring ends are engaged with each other.

## Note:

- ◆ *If ends of installed piston rings are not the locking type (cannot be locked together):*
- ◆ *Always orient the rings so that the gaps (of all three rings) are at the top of the camshaft prior to installation of the camshaft adjustment housing.*
- ◆ *With all ring gaps aligned at the top of camshafts:*
- ◆ *Install camshaft adjustment housing using a gentle side to side motion (do not rock top to bottom).*

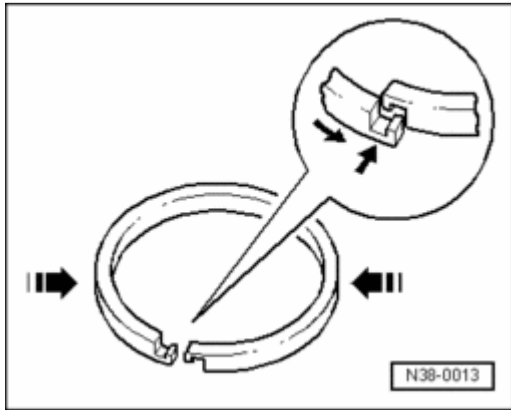

- If necessary, engage ends of installed piston rings (arrows), as depicted in illustration.

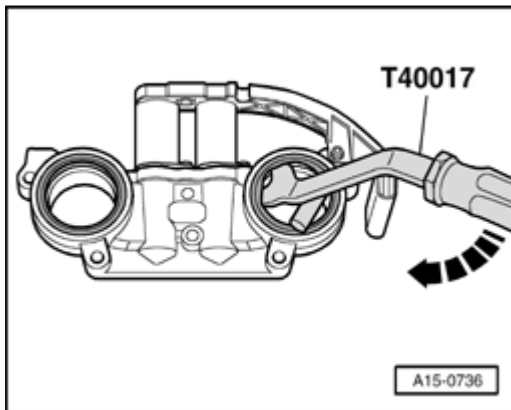

**Note:**

- If the camshaft sealing rings are being replaced, they must be removed from Camshaft adjustment housing before installation, using T40017 lever. Installing camshaft sealing rings ⇒ [Camshaft oil seals, replacing](#) .

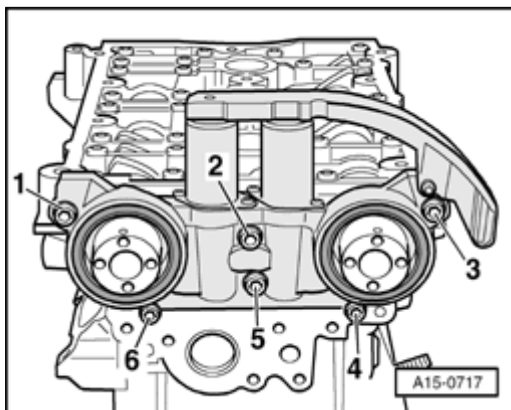

- Install camshaft housing and tighten bolts -1 to 6-.

Installation is reverse of removal, noting the following:

- Install combination valve for Secondary Air Injection ⇒ [Left combination valve for secondary air injection, removing and installing](#) or ⇒ [Right combination valve for secondary air injection, removing and installing](#) .
- Install toothed belt (adjust timing) .

#### Note:

- \* *After installing camshafts, do not start engine for at least 30 minutes. The hydraulic valve lifters have to settle (otherwise valves will strike the pistons).*
- \* *After working on the valvetrain, carefully rotate engine by hand at least 2 full revolutions to ensure that valves do not strike the pistons when starting.*

### Tightening torques

Component	Nm
Guide frame to cylinder head	10
Housing for Camshaft Position (CMP) sensor to cylinder head	10
Housing for camshaft adjustment valve to cylinder head	10
Rear toothed belt guard to cylinder head or cylinder block	10 * <a href="#">See note</a>

\* Replace bolts

Copyright © 2006 Audi of America, Inc. and Bentley Publishers. All rights reserved. Last processed: