



# Technical Service Bulletin

15 Oil leak and/or camshaft DTCs stored - 3.0L

15 08 09 2005587/6 November 7, 2008. Supersedes Technical Service Bulletin Group 15 number 08-08 dated 2005587/5 for reasons listed below.

Model(s)	Year	VIN Range	Vehicle-Specific Equipment
A4	2002 – 2005	All	3.0L V6 Engine
A4 Cabriolet	2003 – 2006	All	
A6	2002 – 2004	All	

## Condition

REVISION HISTORY		
Revision	Date	Purpose
6	-	<ul style="list-style-type: none"><li>Revised <i>Service</i> (Step 5b and Figure 2)</li><li>Revised <i>Warranty</i></li><li>Revised <i>Required Parts and Tools</i></li></ul>

- Oil leak at cylinder head around the camshaft adjuster(s).
- Oil leak around toothed belt drive coming from camshaft adjuster(s).
- One or more of the following DTCs may be present:
  - DTC P1519 (17927 Intake Camshaft Control, Bank 1 - Malfunction).
  - DTC P1522 (17930 Intake Camshaft Control, Bank 2 - Malfunction).
  - DTC P0015 (16399 B Camshaft Position, Bank 1 - Timing over-retarded).
  - DTC P0025 (16409 B Camshaft Position, Bank 1 - Timing over-retarded).
- and/or:
  - DTC P1996 (18404 Friction too high, code E1; Intake - Bank 1).
  - DTC P1997 (18405 Friction too high, code A1; Exhaust - Bank 1).
  - DTC P1998 (18406 Friction too high, code E2; Intake - Bank 2).
  - DTC P1999 (18407 Friction too high, code A2; Exhaust - Bank 2).

## Technical Background

Gaskets and/or sealing rings of camshaft adjusters and/or timing case might be leaking.

The internal bolts of camshaft adjuster(s) might have a reduced torque.

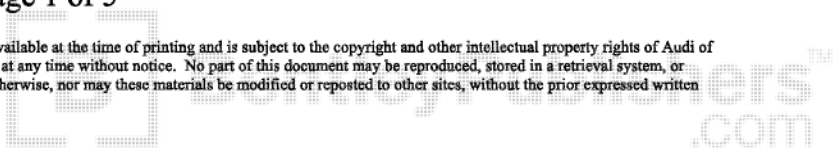

# Technical Service Bulletin

An oil leak also might cause one or more of the mentioned DTCs due to a reduced operating oil pressure in the camshaft adjusters.

## Production Solution

Not applicable.

## Service

If DTC P1519, P1522, P0015, or P0025 is stored:

1. Check for a DTC for a camshaft position sensor (P0340 - P0348, P0365, P0368, P0390 - P0393).  
Do not replace the camshaft adjusters (A) or the camshaft adjustment housings (B) if any camshaft position sensor DTC is present.

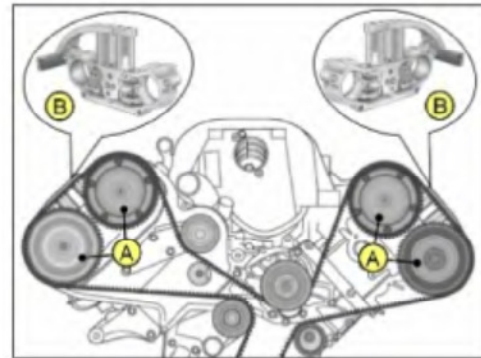

Figure 1. The camshaft adjusters (A) and camshaft adjustment housings (B).

2. Follow Guided Fault Finding test plan for diagnosis.
3. Perform TSB 2005581 if applicable for affected VIN.
4. Check for sufficient oil pressure.  
If oil pressure is too low, also check for oil leaks from or around the camshaft adjusters. These DTCs can also be caused by a malfunctioning camshaft position sensor (G40/G163/G300/G301).

If DTC P1996, P1997, P1998 or P1999 is stored:

1. Do not replace the camshaft adjusters (Figure 1, A) or camshaft adjustment housings (Figure 1, B) because of these DTCs.
2. Follow Guided Fault Finding test plan for diagnosis.
3. Erase the DTC memory. These DTCs only occur during the break-in period of the cylinder head and are not causing the MIL.
4. Check for sufficient oil pressure. If the oil pressure is too low, also check for oil leaks from/around the camshaft adjusters.

# Technical Service Bulletin

5. In case of an oil leak from a camshaft adjuster, perform the following repairs only on the affected side.

- a. Do not replace the camshaft adjusters (Figure 1, A) or camshaft adjustment housings (Figure 1, B)
- b. Replace gasket (Figure 2, 1) and O-rings (Figure 2, 3) between camshaft adjustment housing (Figure 2, B) and cylinder head.

Replace both camshaft sealing rings (Figure 2, 2) (See Repair Manual, Group 15, "Camshaft and camshaft adjusters, removing and installing")

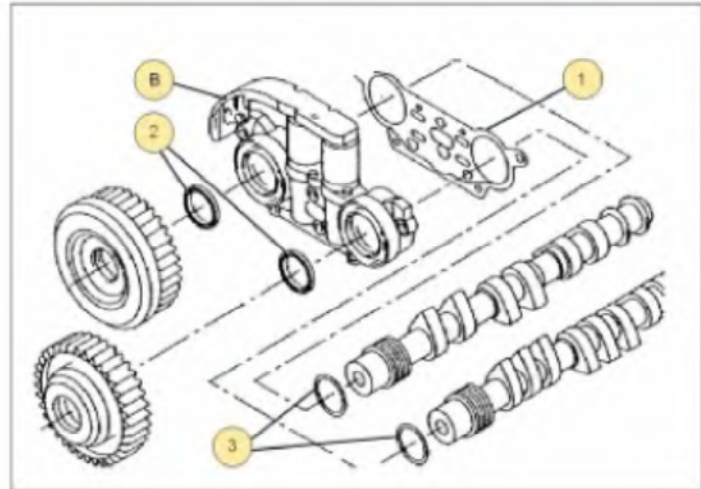

Figure 2. The gasket (1), camshaft adjustment housing (B), camshaft sealing rings (2) and O-rings (3).

### Before Reinstalling the Valve Covers

1. Retorque all five outer bolts (Figure 3, 3) on all four camshaft adjusters to 15 Nm. (The bolt heads are located on the back side of the camshaft adjuster gears.)
2. Replace missing or damaged bolts (part number WHT 003 121).
3. Replace caps (Figure 3, 4) and O-Rings (Figure 3, 5) and secure with securing ring (See Repair Manual, Group 15, "Camshaft and camshaft adjusters, removing and installing.")
4. Reassemble removed components and complete the repair.

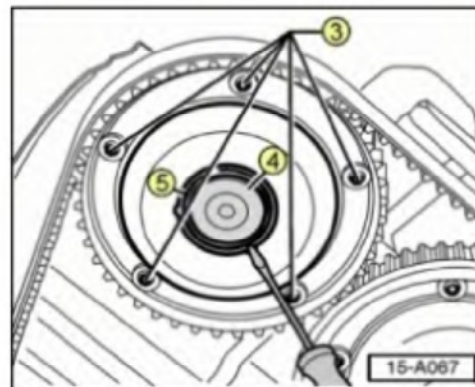

Figure 3. The outer bolts (3), caps (4), and O-Rings (5).

## Warranty

When procedure applies to vehicles under warranty, use the following:

SAGA

Claim Type:	110
-------------	-----



# Technical Service Bulletin

Service Number:	1584		
Damage Code:	0050		
Labor Operations:	A4 / A4 Cabriolet: Camshaft Adjuster remove + reinstall (either bank 1 or bank 2)	15 84 19 71	290 TU
	A4 / A4 Cabriolet: Camshaft Adjuster remove + reinstall (both banks)	15 84 20 71	330 TU
	A6: Camshaft Adjuster remove + reinstall (either bank 1 or bank 2)	15 84 19 99	290 TU
	A6: Camshaft Adjuster remove + reinstall (both banks)	15 84 20 99	330 TU
	Lock carrier loosened + fastened	50 38 09 00	160 TU
	Re-torquing of all 20 bolts of all 4 camshaft adjusters	15 84 14 99	40 TU
	Diagnostic Time:	GFF	0150 0000
Road test prior to service procedure		No allowance	0 TU
Road test after service procedure		01 21 00 04	10 TU
Technical diagnosis at dealer's discretion (Refer to Section 2.2.1.2 and Audi Warranty Online for DADP allowance details)			
Claim Comment:	As per TSB #2005587/6		

All warranty claims submitted for payment must be in accordance with the *Audi Warranty Policies and Procedures Manual*. Claims are subject to review or audit by Audi Warranty.

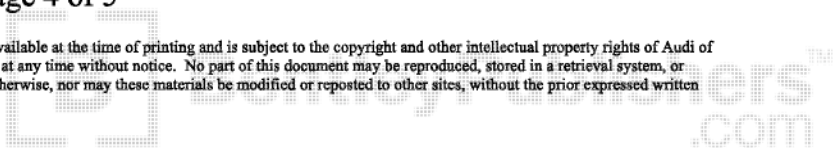



# Technical Service Bulletin

---

## Required Parts and Tools

Part Number	Part Description	Qty
06C 103 121 J	Gasket (1)	1 per affected bank
06C 103 085	Sealing Ring (2)	2 per affected bank
06C 109 144	Sealing Cap (4) including O-Ring (5)	1 per affected adjuster
N 909 804.01	Securing Ring (circlip)	based on need
WHT 003 121	M6 Bolt (if required)	based on need
066-109-345-A	O-Ring	based on need

## Additional Information

All parts and service references provided in this TSB are subject to change and/or removal. Always check with your Parts Department and service manuals for the latest information.