

Camshaft Position Sensor, Checking

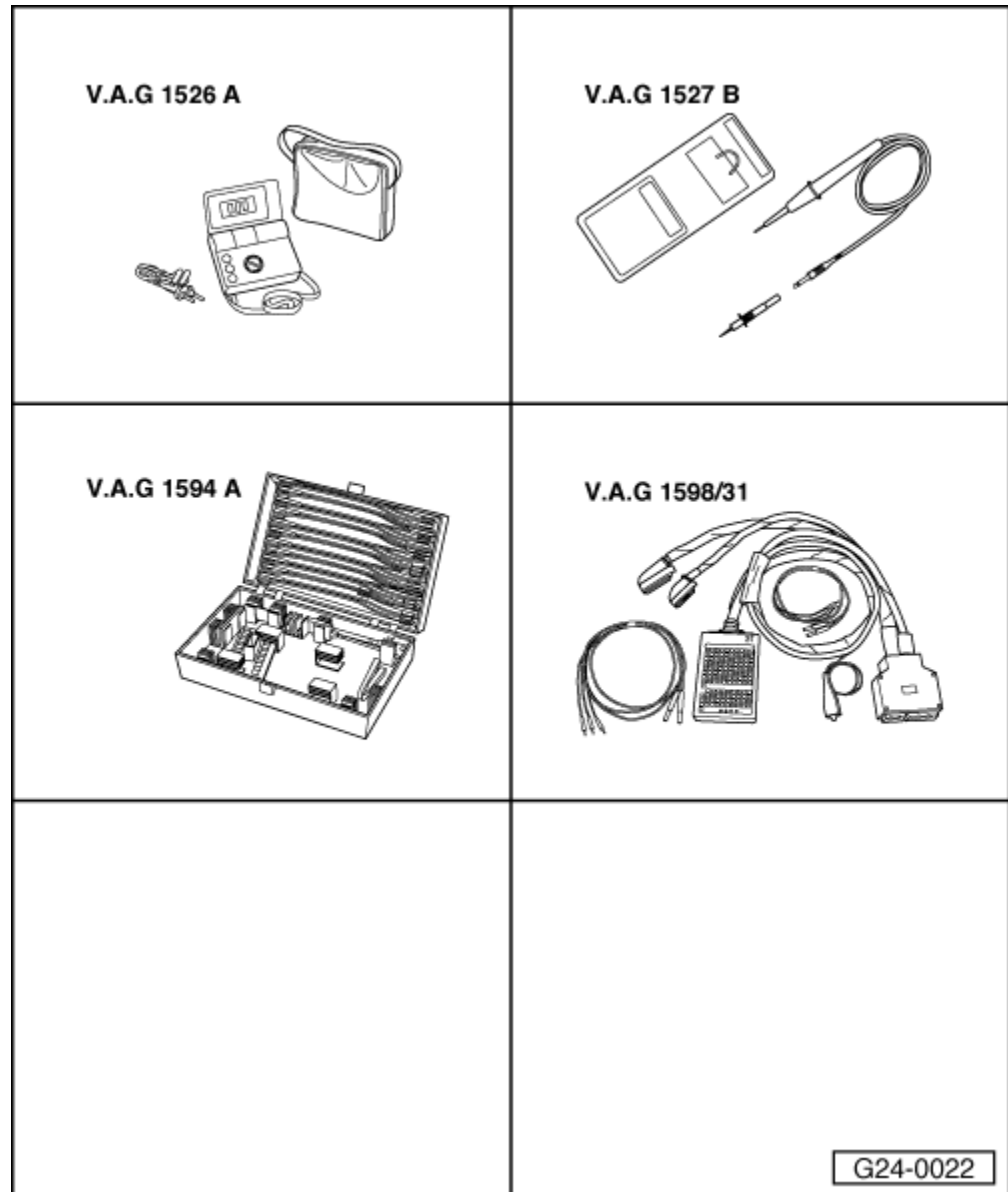

Special tools and workshop equipment required

- ◆ multimeter -VAG1526A-
- ◆ Voltage Tester -VAG1527B-
- ◆ connector test kit -VAG1594A-
- ◆ test box -VAG1598/31-

Component location Overview of component locations - → [Chapter](#)



Note

To reach the harness connectors at cylinder bank 2 (left), the left cover in engine compartment must

be removed, the wire to Engine Coolant Level (ECL) Warning Switch at bottom on reservoir must be disconnected, bolt -arrow- of coolant reservoir must be unscrewed and set it aside. Coolant hoses -1- to -3- remain connected.

Test requirement:

- Ignition switched off.

Checking activation

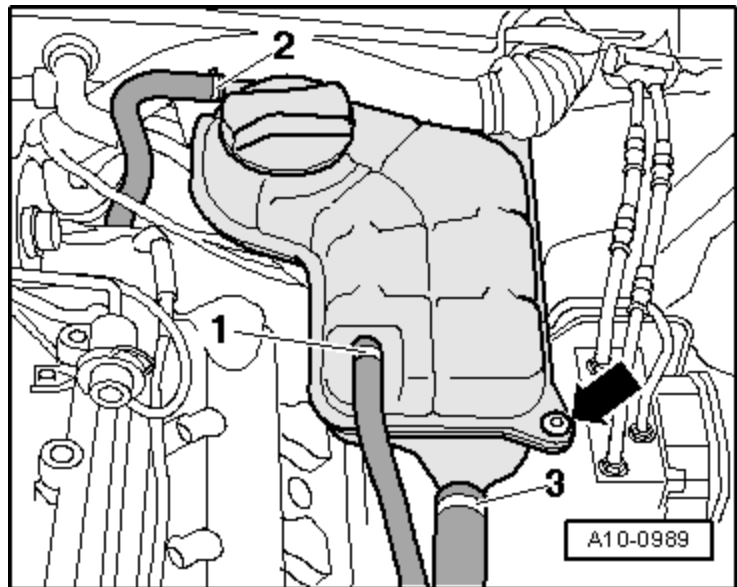

- Connect e.g. voltage tester -VAG1527B- with measuring probes and connector from adapters -VAG1594A- between socket 2 (CMP sensor signal) and socket 1 (B+); the harness connector remains connected.



Note

Connector socket numbers are shown on the rear side of the connector.

- Operate starter for a few seconds.
- ♦ LED must blink.



Note

Voltage testers do not go out completely during low current pick-up between activations by the ECM, but rather continue to glow a little and then get significantly brighter during activation.

- Switch ignition off.

If LED does not blink:

Checking voltage supply

- Disconnect electrical harness connectors -1- and -2- at Camshaft Position (CMP) Sensor - G40- and Camshaft Position (CMP) Sensor 3 - G300-.

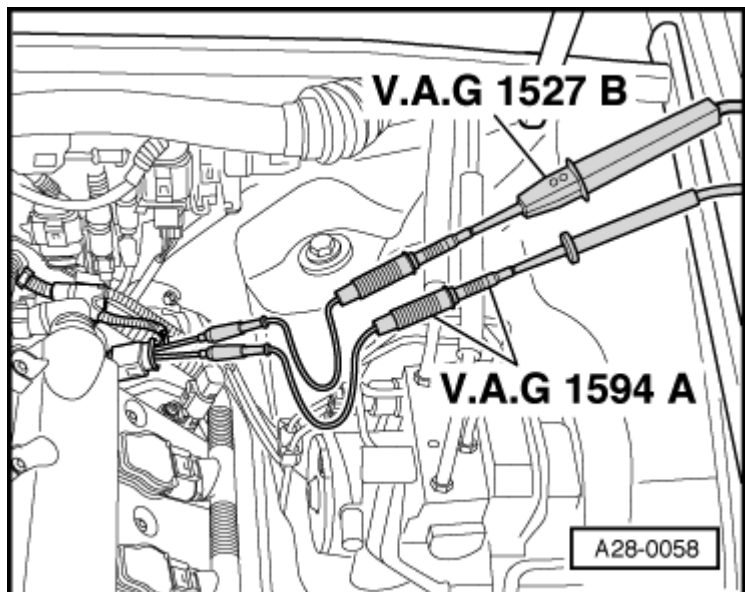

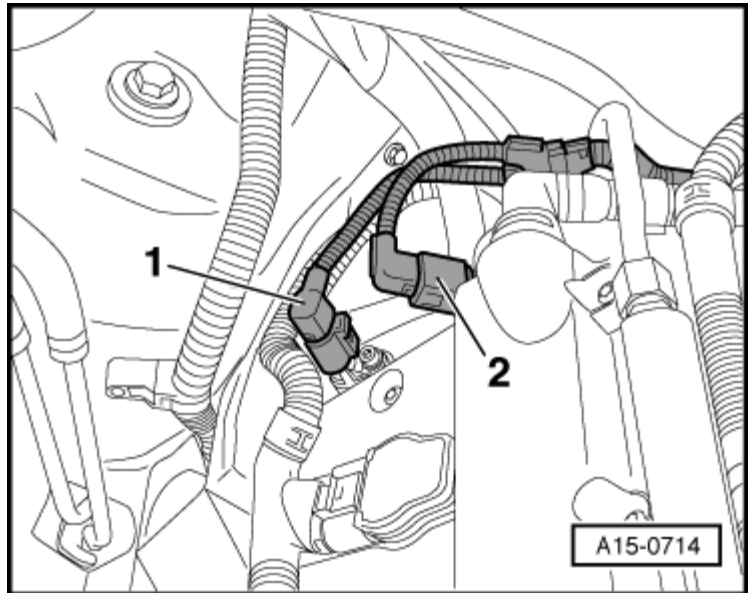

- Disconnect electrical harness connectors -1- and -2- at Camshaft Position (CMP) Sensor - G163- and Camshaft Position (CMP) Sensor 3 -G301-.

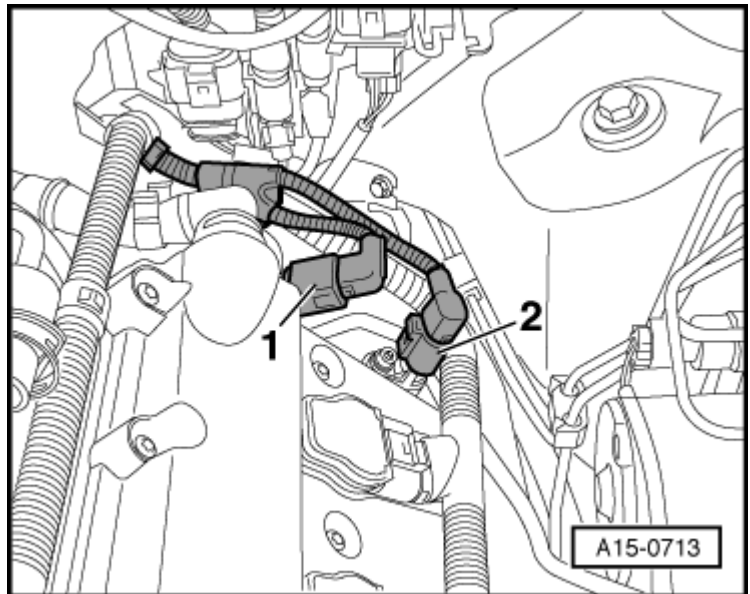

- Connect multimeter for voltage measurement as follows:

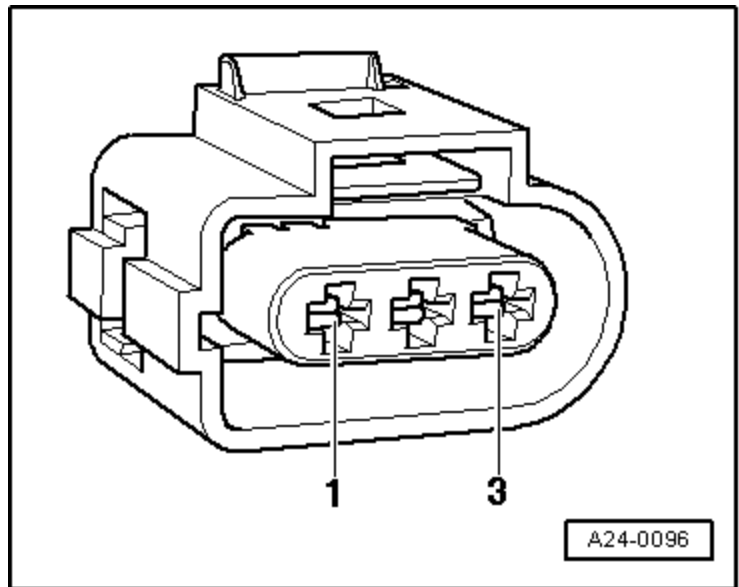

Harness connector Terminal	Measure to
1	Engine Ground (GND)

- Switch ignition on.

Specified value: about 5 V

- Switch ignition off.

Checking signal wire

- Connect multimeter for voltage measurement as follows:

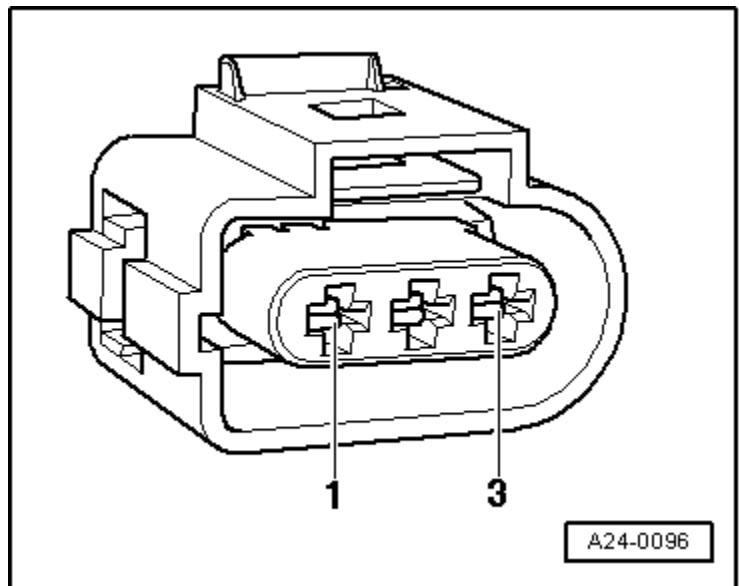

Harness connector Terminal	Measure to
2	Engine Ground (GND)

- Switch ignition on.

Specified value: approx. battery voltage

- Switch ignition off.

Checking Ground (GND) wire

- Connect multimeter for voltage measurement as follows:

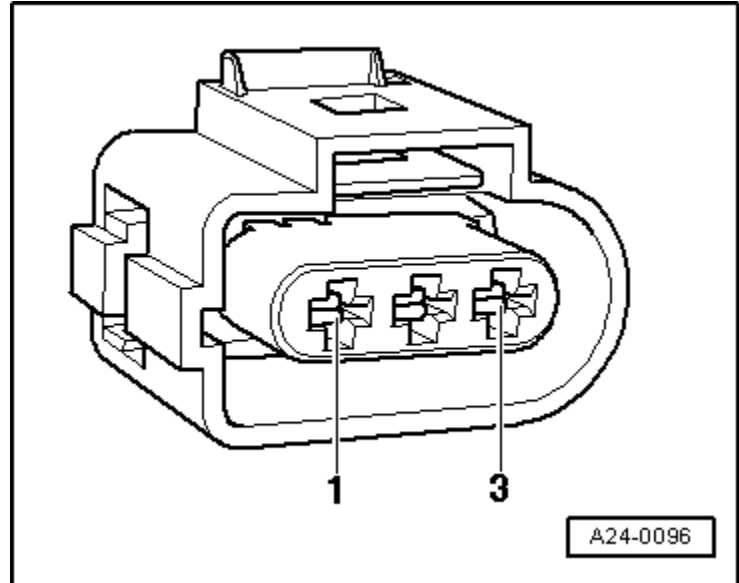

Harness connector Terminal	Measure to
3	B+

Specified value: about 10 V

If all specified values are being reached and the LED does not blink (measured between terminal 1 and 2 with starter and connector connected):

- Replace Camshaft Position (CMP) sensor.

If specified values are not obtained:

Checking wire connections between Camshaft Position (CMP) sensor and Engine Control Module (ECM)

- Connect test box to wiring harness of Engine Control Module (ECM) → [Chapter](#); ECM is not connected.
- Check the following wire connections for open circuit according to wiring diagram:
 - Camshaft Position (CMP) Sensor 2 -G40- (bank 1)

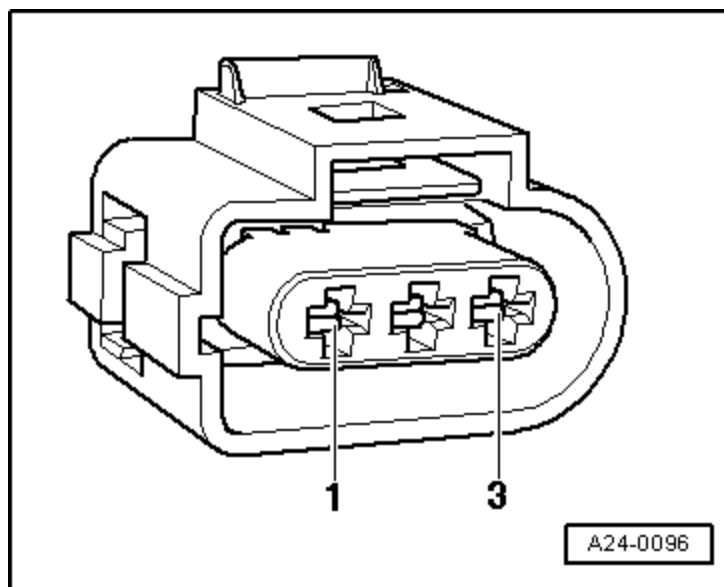

Harness connector Terminal	Test box Socket
1 (B+)	98
2 (signal)	87
3 (Ground -GND-)	108

- Camshaft Position (CMP) Sensor 2 -G163- (bank 2)

Harness connector Terminal	Test box Socket
1 (B+)	98
2 (signal)	86
3 (Ground -GND-)	108

- Camshaft Position (CMP) Sensor 2 -G300- (bank 1)

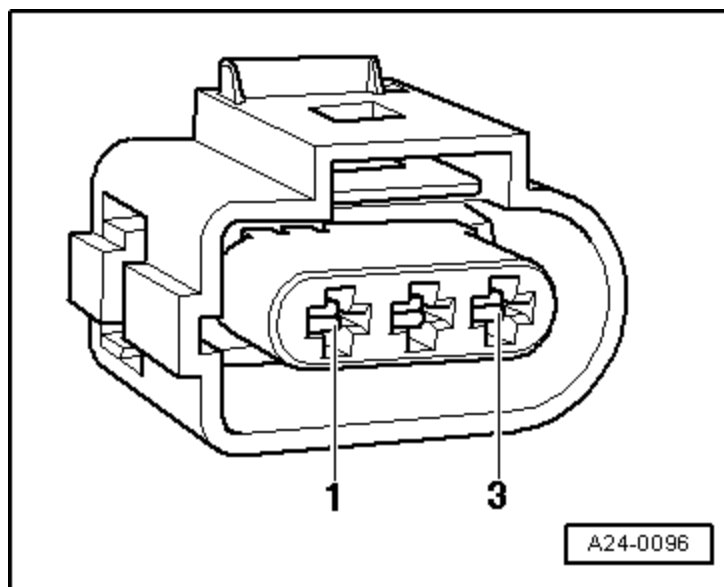

Harness connector Terminal	Test box Socket
1 (B+)	98
2 (signal)	81
3 (Ground -GND-)	108

- Camshaft Position (CMP) Sensor 2 -G301- (bank 2)

Harness connector Terminal	Test box Socket
1 (B+)	98
2 (signal)	54
3 (Ground -GND-)	108

Specified value: Wire resistance max 1.5 Ω

- Check wires for short circuit to each other as well as to B+ and Ground (GND).

Specified value: $\infty \Omega$ (no continuity)

- If necessary, repair wire connection.

Final procedures

After repair work, the following work steps must be performed in the mentioned sequence:

- 1 - Check DTC memory "Mode 3: Check DTC memory" → Chapter.
- 2 - If necessary, erase DTC memory "Mode 4: Reset/erase diagnostic data" → Chapter.
- 3 - Generate readiness code → Chapter.

- End diagnosis and switch ignition off.