

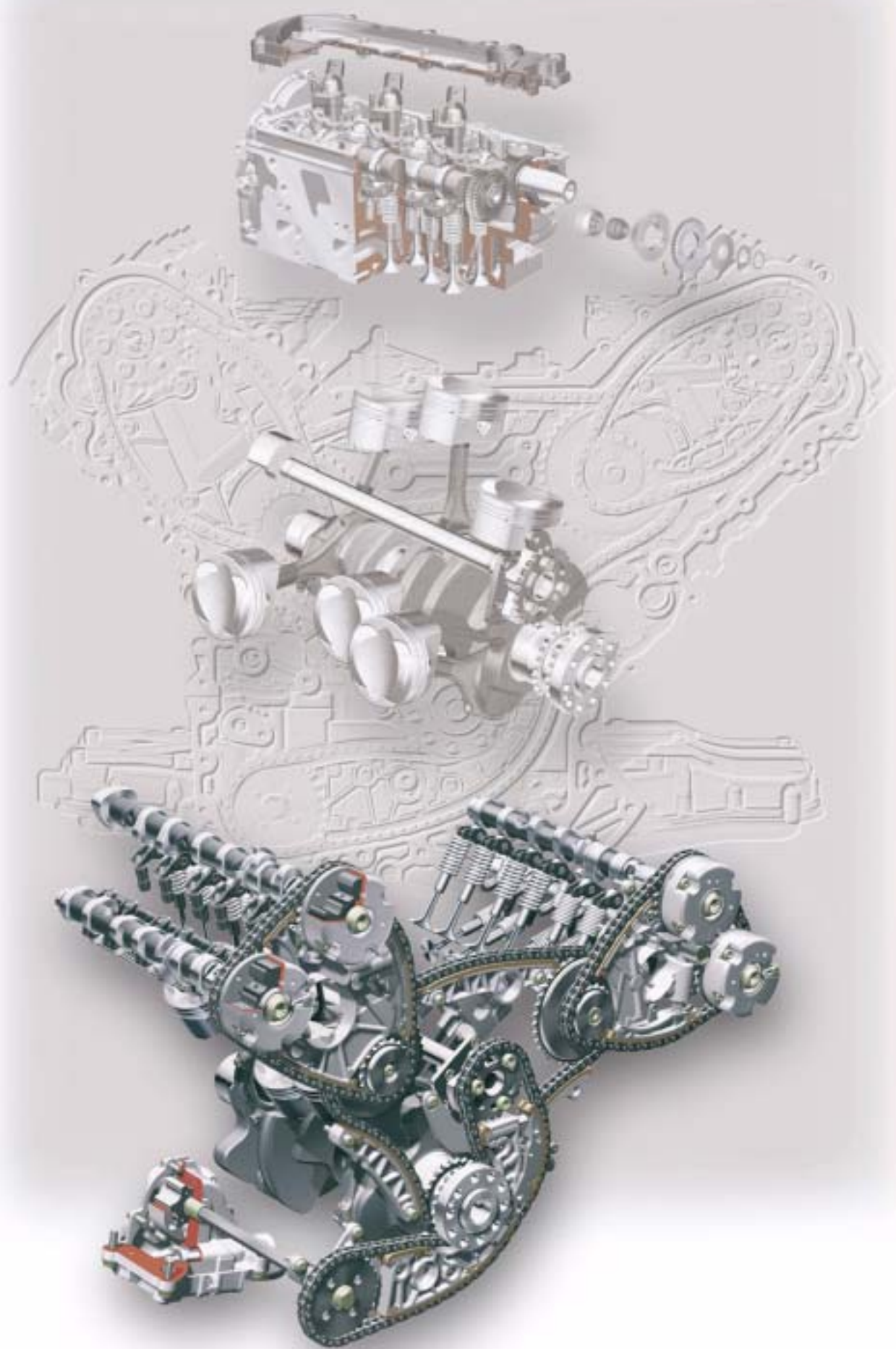

AUDI engines – Chain drives

Self-Study Programme 327



A compact engine design has been achieved by positioning the chain drive on the gearbox side and by using a four-piece chain drive distributed on two planes. Thus, it is possible to install multi-cylinder engines in smaller model series without the need for extending the front end of the vehicle. The chain drive helps reduce operating costs, because it is maintenance free and designed for long life.

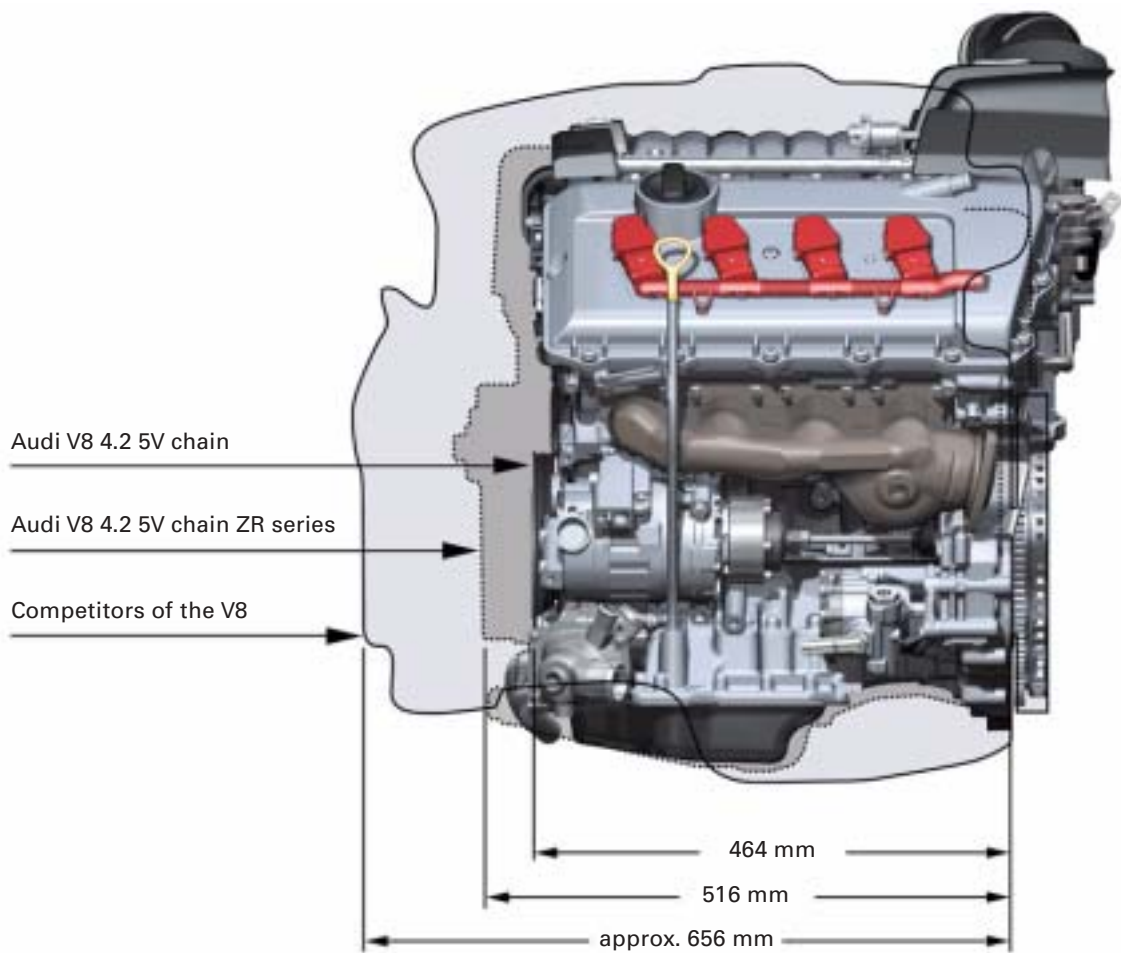

Table of contents

Contents	4
Introduction.....	6

1.6-litre R4 FSI engine

Description	8
Performance features	9
Chain drive	10
Intake system	12
Oil circuit	14
Cooling system.....	15
Fuel system.....	16

3.2-litre V6 FSI engine

Description	18
Performance features	19
Chain drive	20
Intake manifold.....	23
Oil circuit	24
Cooling system.....	25
Petrol direct injection with supply on demand fuel system	26

3.0-litre V6 TDI engine

Description	28
Performance features	29
Chain drive	30
Backlash compensation	31
Intake manifold.....	32
Charging	33
Fuel system.....	34

4.0-litre V8 TDI engine

Description	36
Performance features	37
Chain drive	38
Engine lubrication	39
Cooling system.....	40
Air intake	41
Fuel system.....	43
Charging	44
Exhaust system	45

4.2-litre V8 engine

Description	46
Performance features	47
Chain drive	48
Intake system	51

6.0-litre W12 engine

Description	52
Performance features	53
Chain drive	54
Cooling system.....	56
Oil circuit	57
Exhaust system	58

The Self-Study Programme imparts a basic knowledge of the design and function of new models, new automotive components or new technologies.

The Self-Study Programme is not a Repair Manual!
The values given are intended as a guideline only and refer to the software version valid at the time of publication of the SSP.

For maintenance and repair work, always refer to the current technical literature.

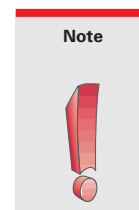
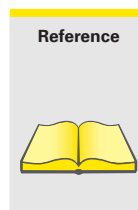

Overview

Audi engines with camshaft timing chain

In the Audi engines specified below, the camshaft is timed by a chain drive.

3.2-litre V6 FSI engine



327_002

1.6-litre R4 FSI engine



327_001_1

6.0-litre W12 engine

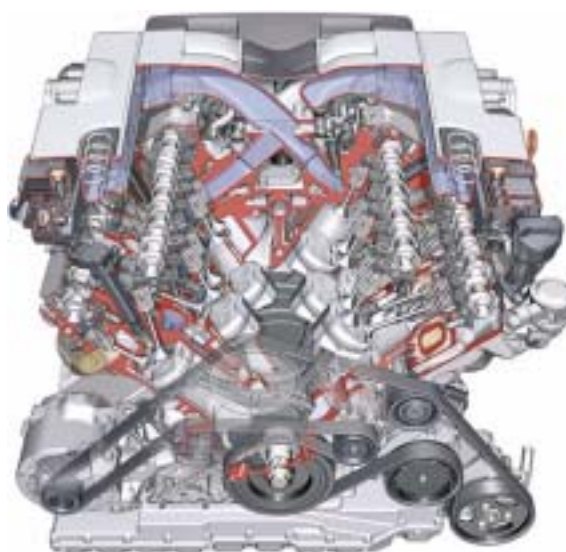

327_006

3.0-litre V6 TDI engine



327_003

4.0-litre V8 TDI engine



327_004

4.2-litre V8 engine



327_005

1.6-litre R4 FSI engine

Description

Technical features

- Camshafts driven by timing chains
- Air filter integrated in the engine cover
- Oil circuit with closed-loop Duocentric oil pump
- Dual circuit cooling system
- Petrol direct injection with supply on demand fuel system
- Bosch Motronic MED 7.5.11 petrol direct injection system



327_001

Reference



For further information, please refer to SSP 296 - The 1.4-litre and 1.6-litre FSI engines with timing chain.

Performance features

Torque and power output

The engine code and engine number can be found on the left-hand side of the cylinder block under the battery mounting.



327_022

Torque/power curve

- Max. torque in Nm
- Max. power output in kW

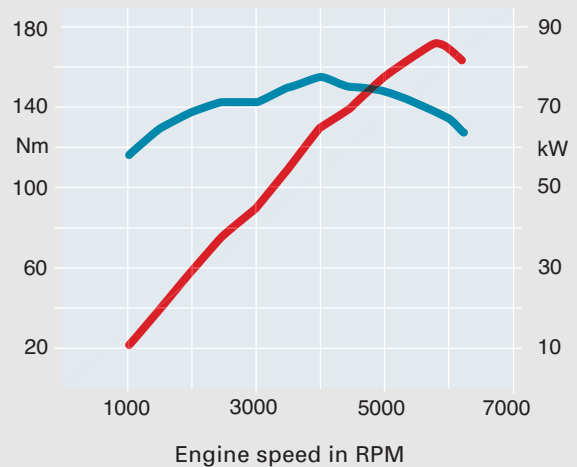

Specifications

Engine code	BAG
Type of engine	4-cylinder inline engine
Displacement in cm ³	1598
Max. power output in kW (bhp)	85 (115) at 6000 RPM
Max. torque in Nm	155 at 4000 RPM
Number of valves per cylinder	4
Bore in mm	76.5
Stroke in mm	86.9
Compression ratio	12 : 1
Firing order	1-3-4-2
Fuel grade	Super Plus unleaded, at least 98 RON (unleaded Super, 95 RON, as an alternative with slight reduction in performance)
Exhaust emission control	Close-coupled primary catalytic converter, NO _x storage catalytic converter, Exhaust gas recirculation
Engine management	Fully electronic engine management with drive-by-wire throttle control
Emission category	EU IV

1.6-litre R4 FSI engine

Chain drive

Driven camshafts

The overhead camshafts are driven directly by the crankshaft via a timing chain.

The camshaft timing chain is guided by a slide rail and tensioned by the tensioning rail.

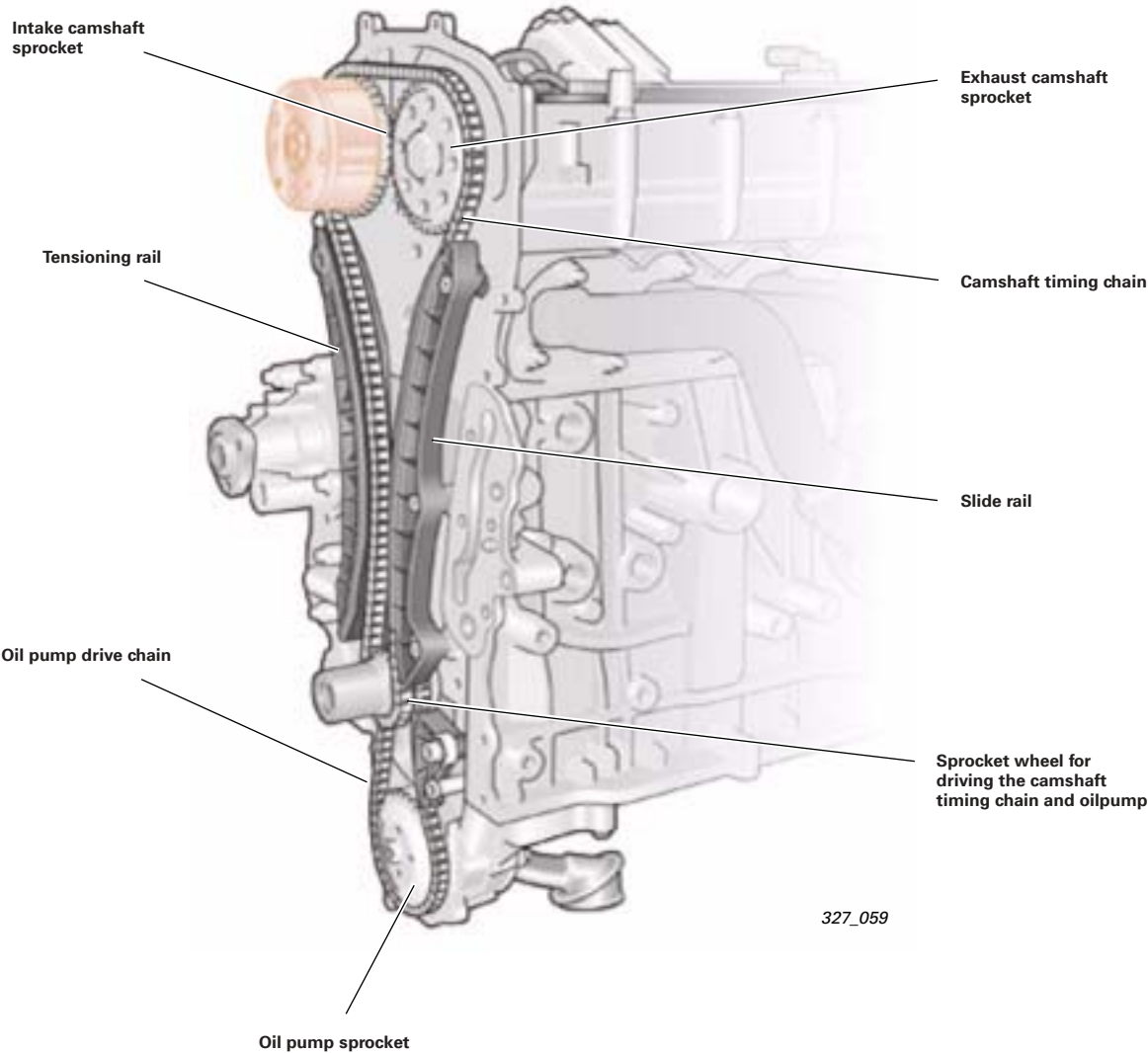

Camshaft adjuster

The intake camshaft can be adjusted in dependence on engine speed and load. The camshaft timing is adjusted continuously over a range of 20° camshaft angle in the "advance" direction relative to the basic setting.

A vane cell adjuster, which is actuated by the engine oil pressure, is used as the adjustment mechanism. Intake camshaft timing adjustment valve -1- is activated by the engine control unit. It regulates the oil pressure in the camshaft adjuster, and hence the camshaft timing.

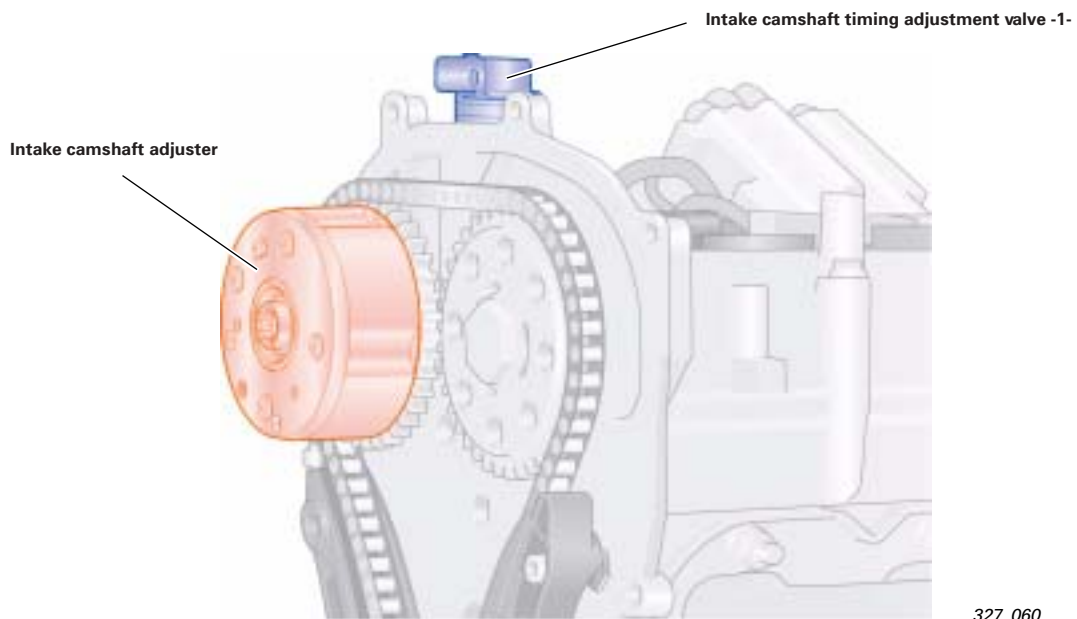

327_060

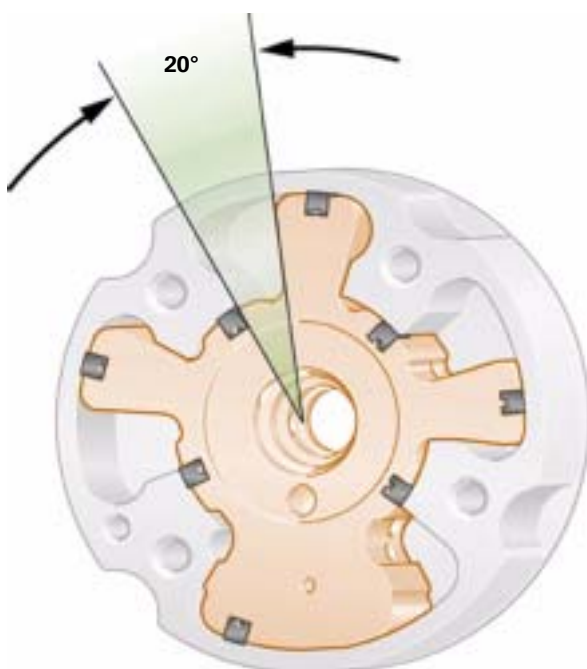

327_061

Camshaft adjuster

The camshaft adjuster housing is rigidly connected to the intake camshaft sprocket, the internal rotor to the intake camshaft. The oil inlet pressure causes the internal rotor to counter-rotate relative to the housing, thus adjusting the camshaft.

1.6-litre R4 FSI engine

Intake system

Engine cover

The following parts are integrated in the engine cover:

- the air filter,
- the air duct running from the air inlet to the throttle valve control unit,
- the air duct for intake noise absorption,
- the hot air feed control thermostat and
- intake air temperature sender -2- for engine load calculation

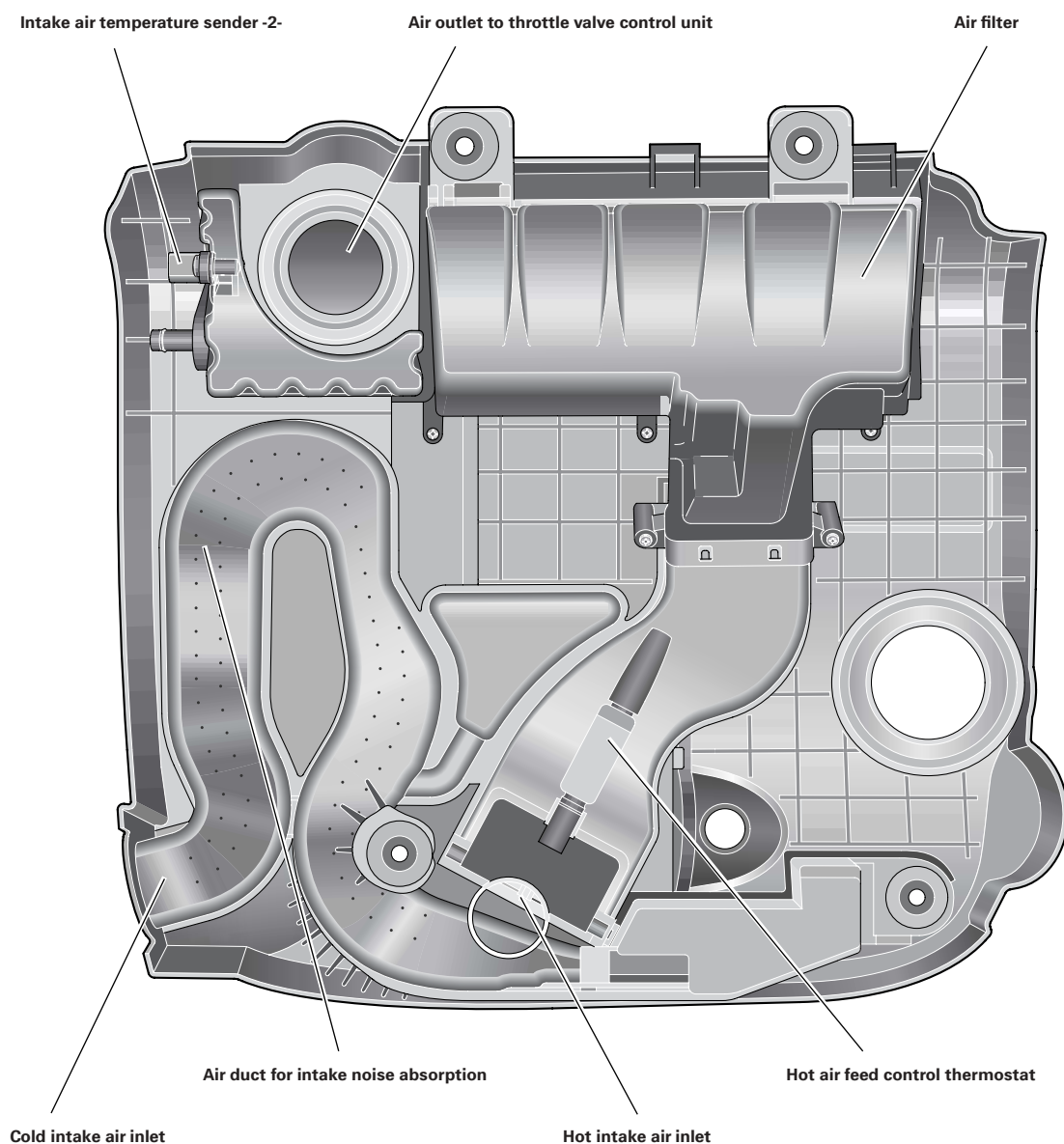

327_062

Intake manifold upper section

The upper section of the intake manifold is made of plastic and accommodates the vacuum reservoir required to operate the intake manifold flaps.

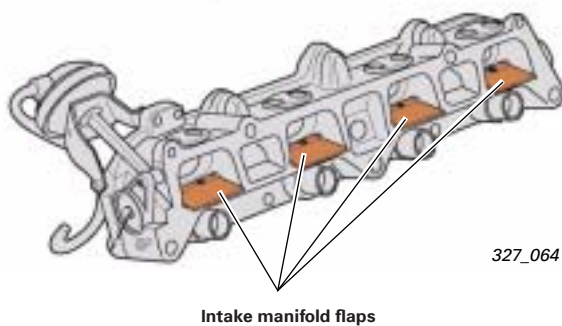
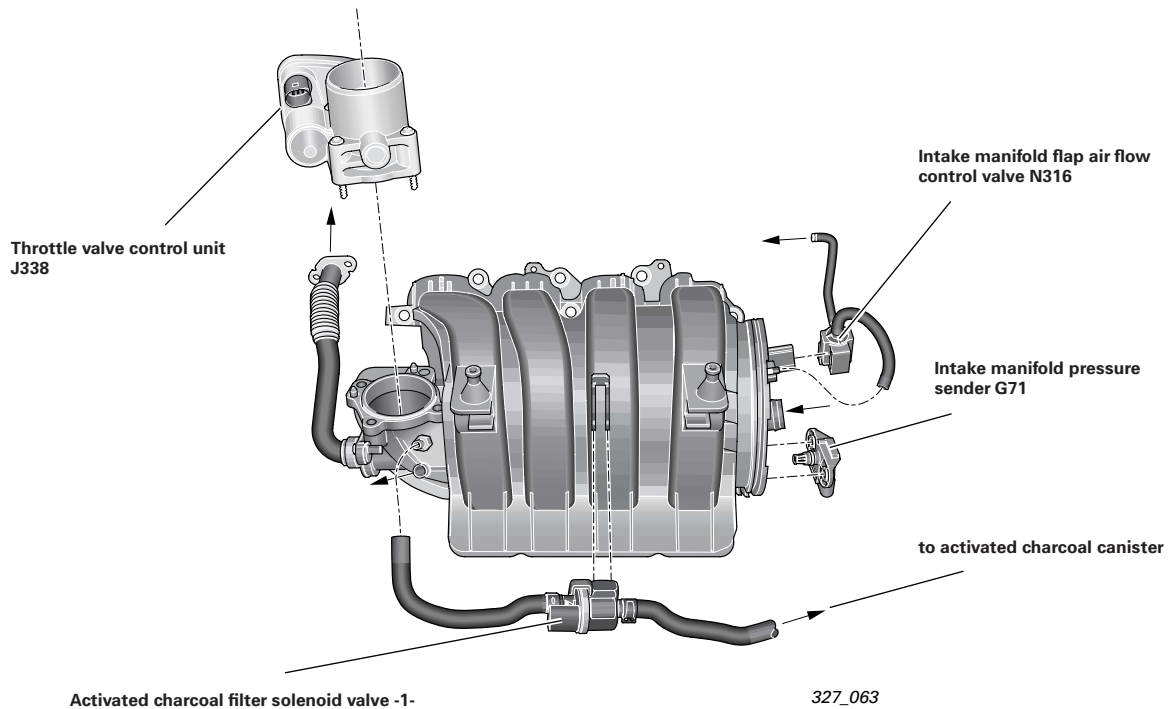

Fuel distributor (intake manifold lower section)

The fuel distributor represents the lower section of intake manifold and is bolted to the cylinder head. In addition to the ports for distributing fuel to the injectors, the fuel distributor accommodates the intake manifold flaps for intake air flow control.

Reference



For a functional description of the intake manifold flaps, please refer to SSP 279 - The 2.0-litre 110 kW engine with petrol direct injection (FSI).

1.6-litre R4 FSI engine

Oil circuit

Controlled Duocentric oil pump

A closed-loop Duocentric oil pump is employed. It maintains a near-constant oil pressure over the entire RPM range.

Oil pressure is regulated by the control spring and control ring integrated in the oil pump.

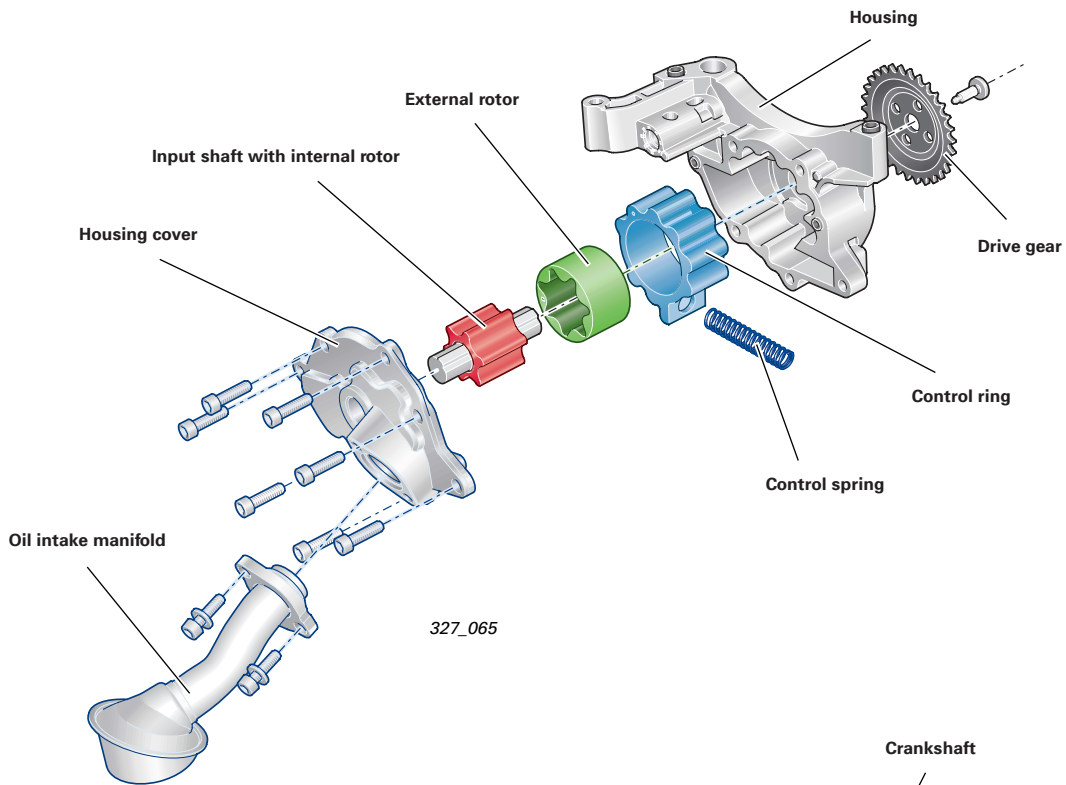

Duocentric oil pump drive

The oil pump is driven by the crankshaft via a separate timing chain. The chain is tensioned by a mechanical chain tensioner.

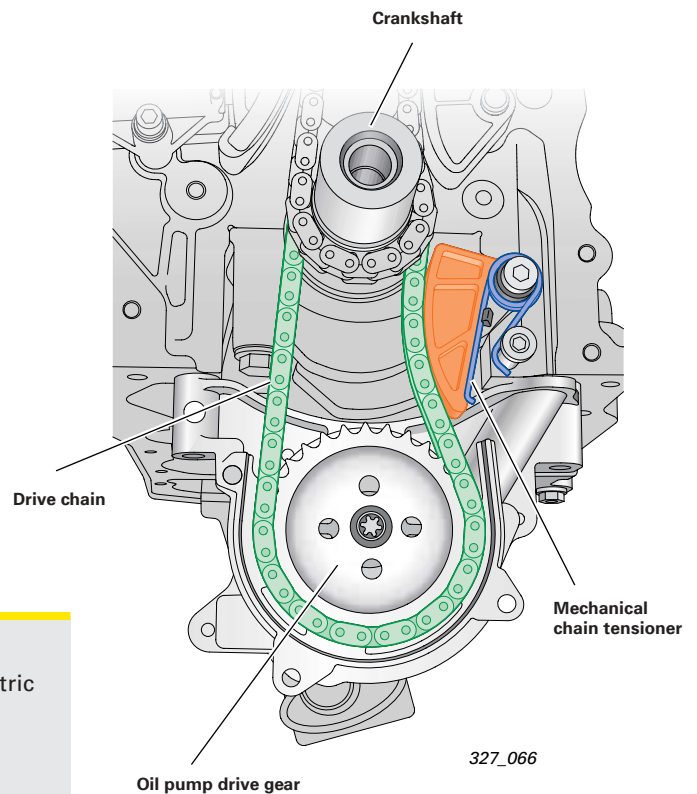

Reference



For a functional description of the Duocentric oil pump, please refer to SSP 296 - The 1.4-litre and 1.6-litre FSI engines with camshaft timing chain.

Cooling system

Coolant circuit

The cooling system has two circuits - one for cooling the cylinder block and one for cooling the cylinder head. One third coolant flows into the cylinder block and two thirds into the cylinder head. Coolant flow is regulated by two thermocouples integrated in the coolant thermostat housing. Whereas the short thermocouple probe for the coolant thermostat regulates coolant flow in the cylinder block, the long thermocouple probe for coolant thermostat regulates coolant flow in the cylinder head.

Both thermocouples are closed up to a coolant temperature of approx. 87 °C, thus allowing the engine to reach operating temperature more quickly.

The long thermocouple probe for the coolant thermostat is open at coolant temperatures from approx. 87 °C to 105 °C and the coolant temperature in the cylinder head is kept at approx. 87 °C. The temperature in the cylinder block can continue to rise.

Both thermocouples are opened when the coolant temperature exceeds 105 °C, whereby the temperature is kept at 87 °C in the cylinder head and 105 °C in the cylinder block.

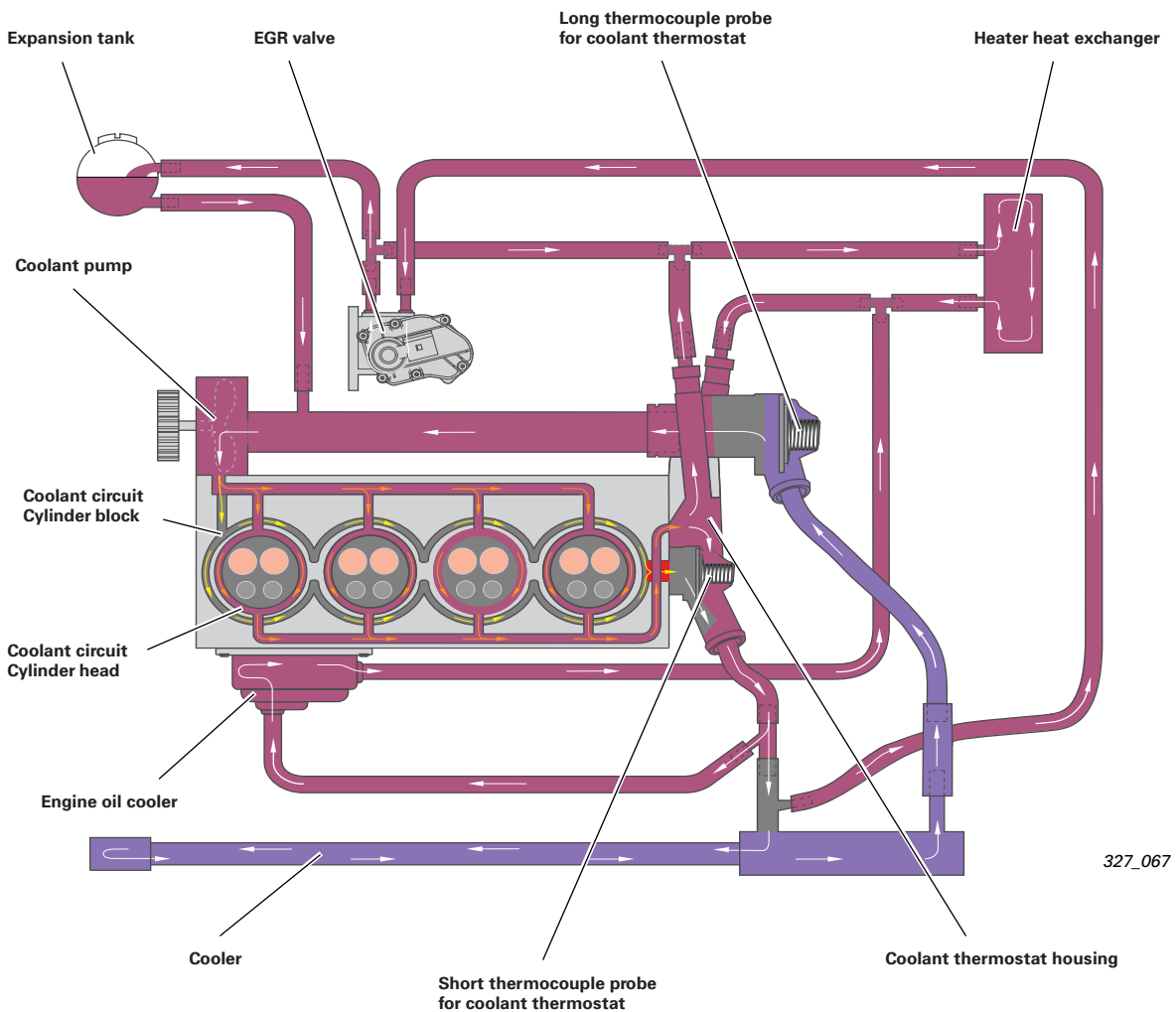

High-pressure circuit

The high-pressure circuit consists of

- the high-pressure fuel injection pump,
- the fuel pressure regulating valve,
- the high-pressure fuel rail,
- the high-pressure fuel pressure sender G247,
- the high-pressure fuel lines and
- the high-pressure injectors.

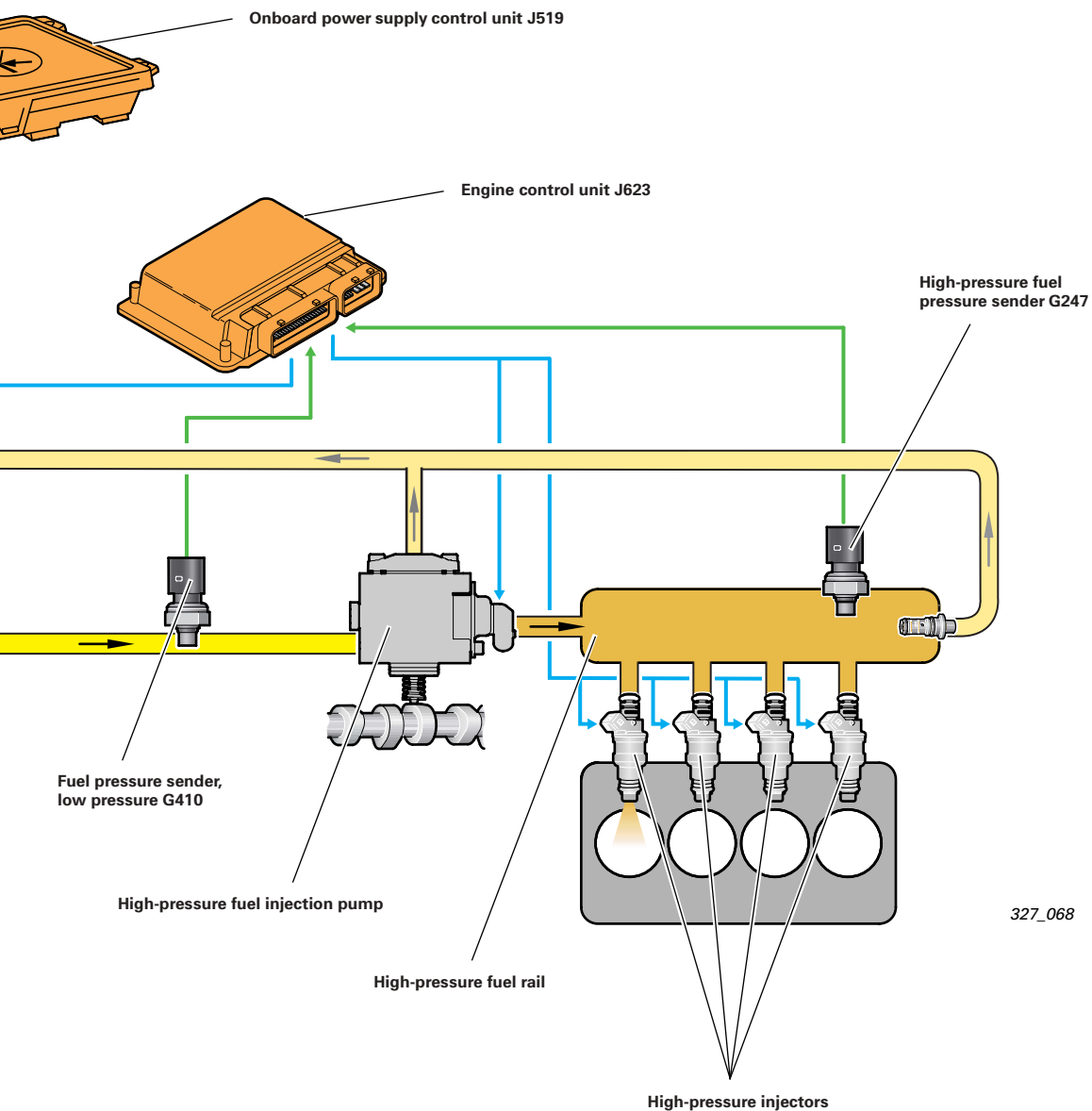

3.2-litre V6 FSI engine

Description

Technical features

- Timing gear with chain
- Timing chain on the transmission side
- Continuously variable valve timing
- Counter-rotating balancer shaft running at engine speed to compensate for crankshaft vibrations
- Twin-path intake manifold made of plastic
- Dual-circuit cooling system
- Oil circuit with Duocentric oil pump and cold start valve
- Petrol direct injection with supply on demand fuel system
- Siemens engine management system



327_002

Reference

For further information, please refer to SSP 325, AUDI A6 '05 - Ancillaries.



Performance features

Engine code, torque and power output

The engine code and engine number can be found on the front left-hand side of the cylinder block.



327_008

Torque/power curve

- Max. torque in Nm
- Max. power output in kW

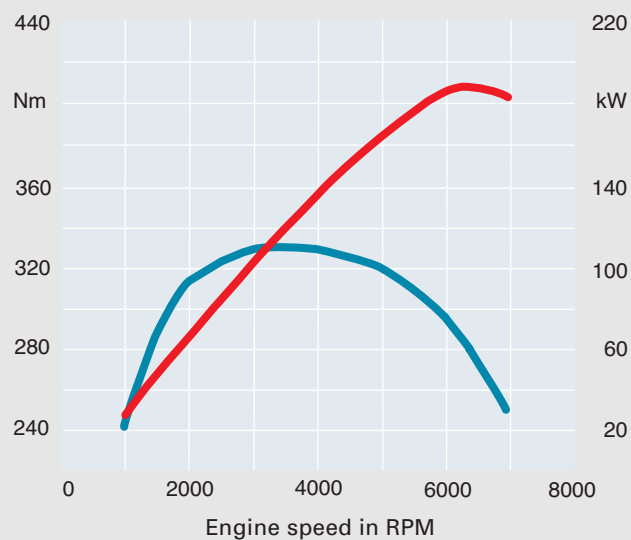

Specifications

Engine code	AUK
Type of engine	6-cylinder vee-engine with 90° included angle
Displacement in cm ³	3123
Max. power output in kW (bhp)	188 (255) at 6500 RPM
Max. torque in Nm	330 at 3250 RPM
Number of valves per cylinder	4
Bore in mm	84.5
Stroke in mm	92.8
Compression ratio	12.5 : 1
Firing order	1-4-3-6-2-5
Fuel grade	Unleaded Super, 95 RON (unleaded regular-grade, 91 RON, as an alternative with slight reduction in performance)
Exhaust emission control	Closed-loop catalytic converter with lambda control, NO _x storage catalytic converter
Engine management	Siemens engine management system
Exhaust emission standard	EU IV

3.2-litre V6 FSI engine

Chain drive

Driven camshaft, oil pump and balancer shaft

A flywheel-side chain drive was selected for the 3.2-litre V6 engine, as it is subject to less load than a front-side chain drive.

The chain drive consists of sprockets A, B and C.

The four camshafts are driven by the crankshaft by pinions A, B and C using a single-bush chain with two intermediate shafts.

The required reduction ratio between the crankshaft and the camshaft is provided by the intermediate shaft.

Hydraulic chain tensioners with built-in non-return valves are used for tensioning the chains. Oil is supplied via a separate riser.

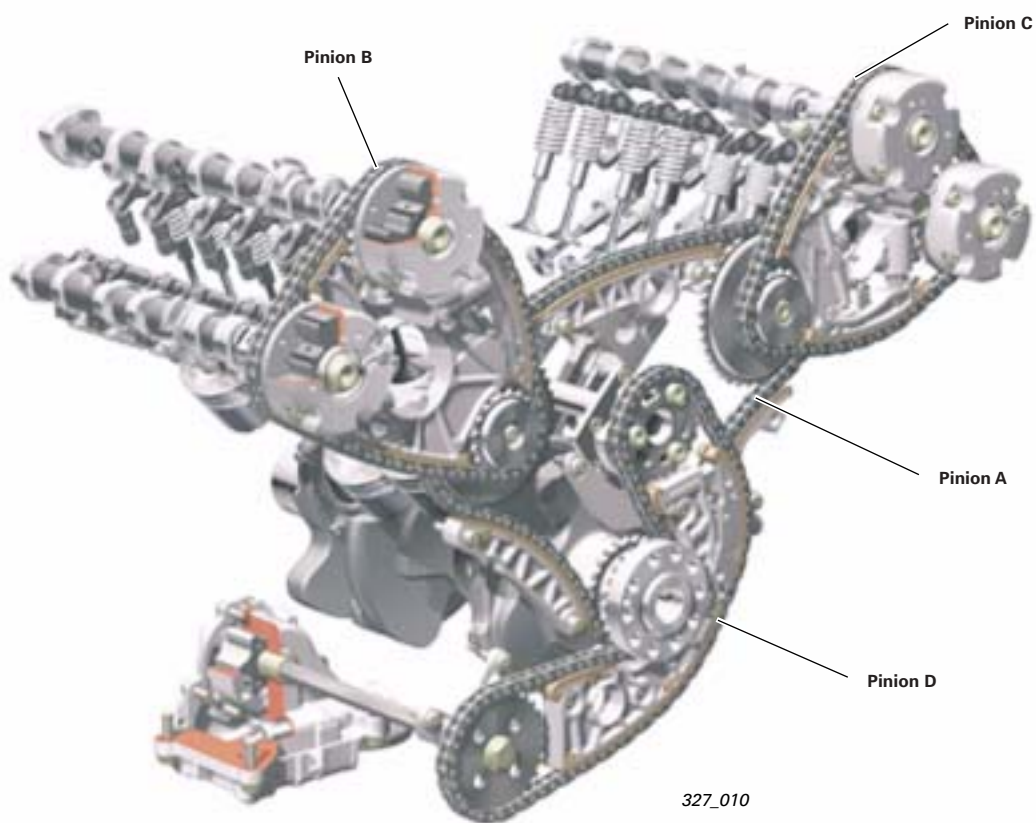

Note



When removing and installing the balancer shaft and oil pump sprockets, attention must be paid to correct installation position as per the workshop manual.

Oil pump drive

Pinion D drives the oil pump and the balancer shaft via a single roller chain.

The chain drive is configured in such a way that the direction of rotation of the oil pump and the balancer shaft are reversed.

The reduction ratio ($i = 0.86$) required for adapting the rotational speed of the oil pump is achieved by using different sprocket wheels.

Continuously variable valve timing

Continuous adjustment of the intake and exhaust camshafts is provided by hydraulic swivel motors. The adjustment range for intake and exhaust camshafts is 42° in the "advance" direction. The adjusters are locked mechanically until the start of adjustment (once the required oil pressure has been reached).

The Simos control unit (J361) controls the adjustment process via intake camshaft timing adjustment valve -1- (N205), intake camshaft timing adjustment valve -2- (N208), exhaust camshaft timing adjustment valve -1- (N318) and exhaust camshaft timing adjustment valve -2- (N319).

Hall sender G40 (cylinder bank 1) and hall sender 2 G163 (cylinder bank 2) supply the signals required to locate the position of the intake camshafts, while hall sender 3 G300 (cylinder bank 1) and hall sender 4 G301 (cylinder bank 2) supply the signals required to locate the position of the exhaust camshafts.

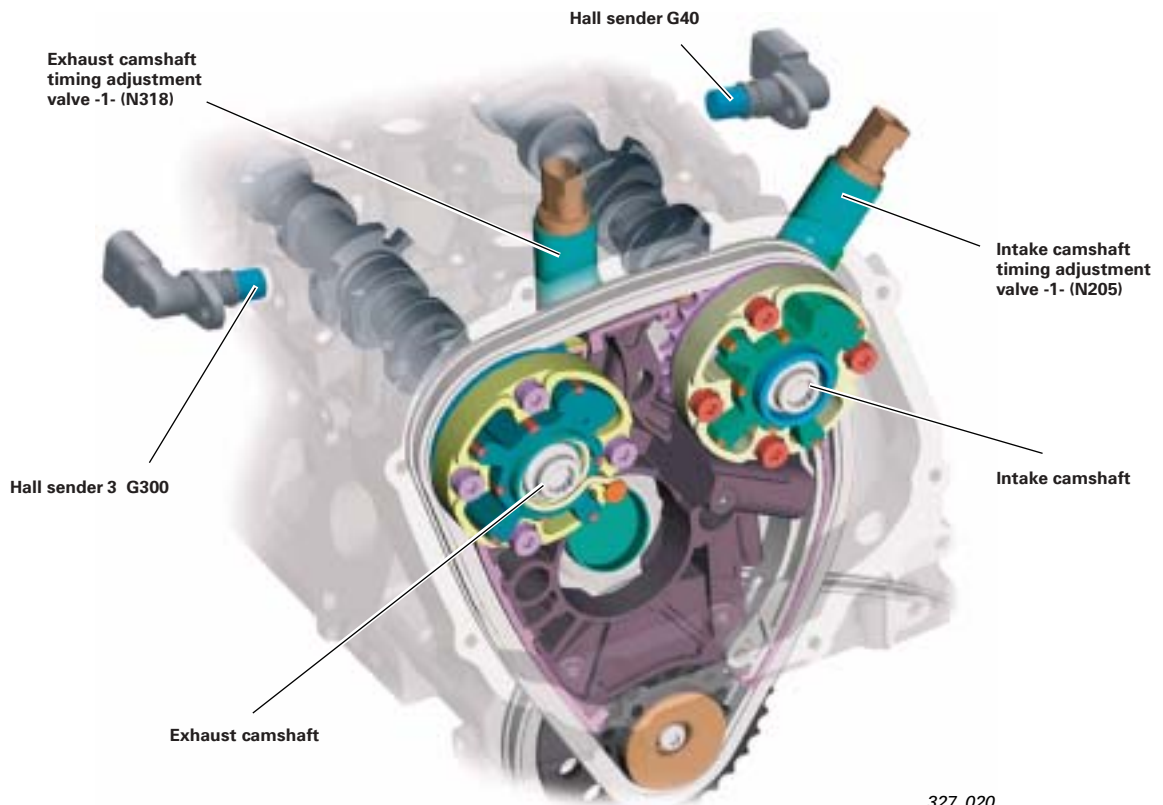

327_020

Variable valve timing adaptation

A distinction is made between basic adaptation and fine adaptation.

Basic adaptation

After the engine is started, the camshafts remain in the starting position until their exact position has been determined in relation to the crankshaft. The values are stored in the Simos control unit. Basic adaptation is carried out when the voltage supply for the Simos control unit is disconnected or the fault memory is erased.

Fine adaptation

Fine adaptation is carried out after the engine is started if the camshafts are in the basic position and the coolant temperature is higher than 85 °C.

3.2-litre V6 FSI engine

Balancer shaft

In V6 engines with a cylinder angle of 90° , free inertial forces will cause the engine to run unevenly. A balancer shaft provides the necessary balancing of masses.

The 3.2-litre V6 FSI engine therefore has a balancer shaft which is driven by the crankshaft via chain drive D. The timing chain is configured in such a way that the balancer shaft rotates in the reverse direction, thus allowing the inertial forces produced by the balancer shaft to counteract the first-order free inertial forces.

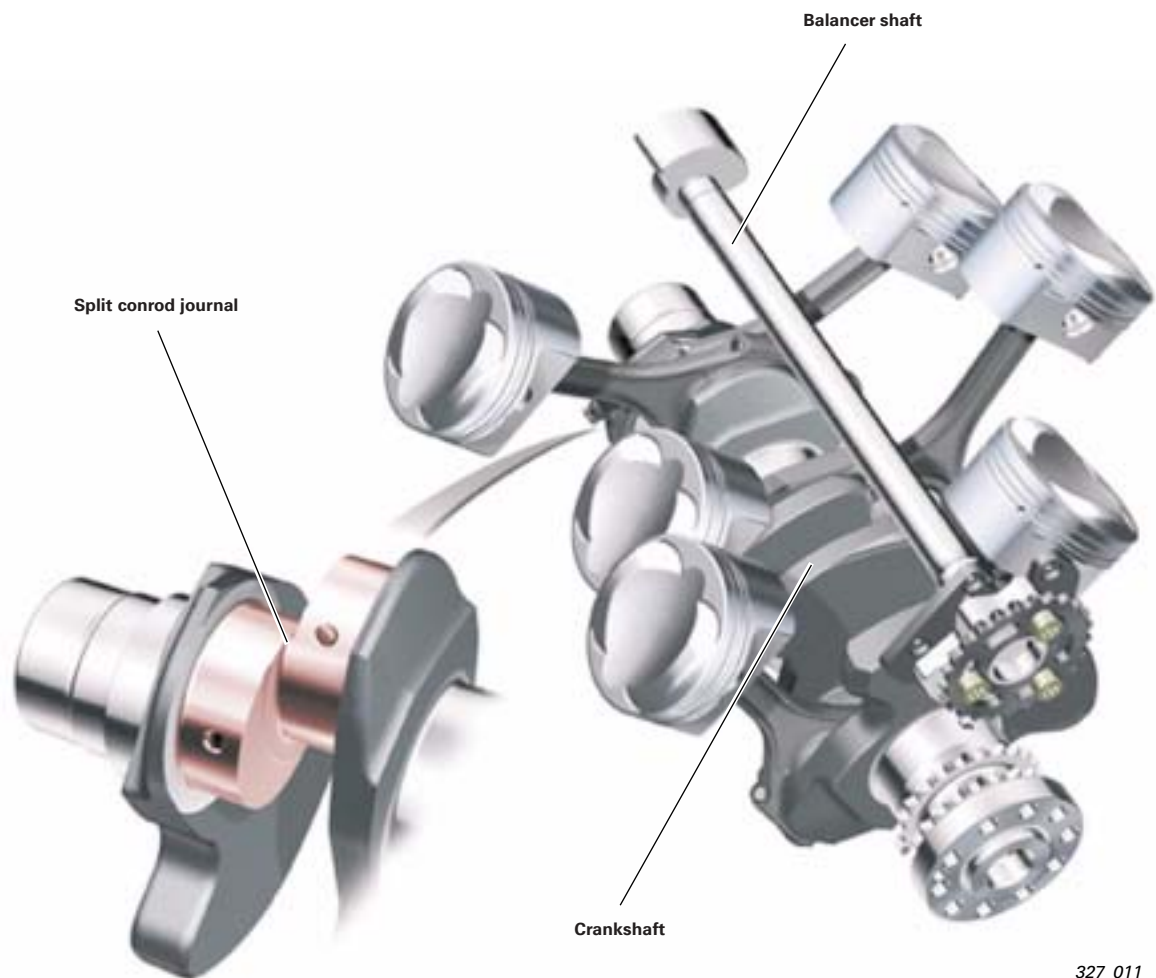

327_011

Intake manifold

Design

A new plastic variable inlet manifold was developed for the 3.2-litre V6 FSI engine. Flow losses were reduced through intensive testing and calculation.

The intake manifold comprises an upper section and a lower section. The vacuum reservoir is an integral part of the intake manifold upper section.

Intake manifold flaps

The variable inlet manifold has two intake manifold flaps operated by two actuating shafts. Both actuating shafts are interconnected by a pair of gears.

The actuating shaft is vacuum-activated by the intake manifold change-over actuator. The vacuum is controlled by the intake manifold flap change-over valve N239.

The Simos control unit recognises the position of the intake manifold flaps via the variable inlet manifold potentiometer.

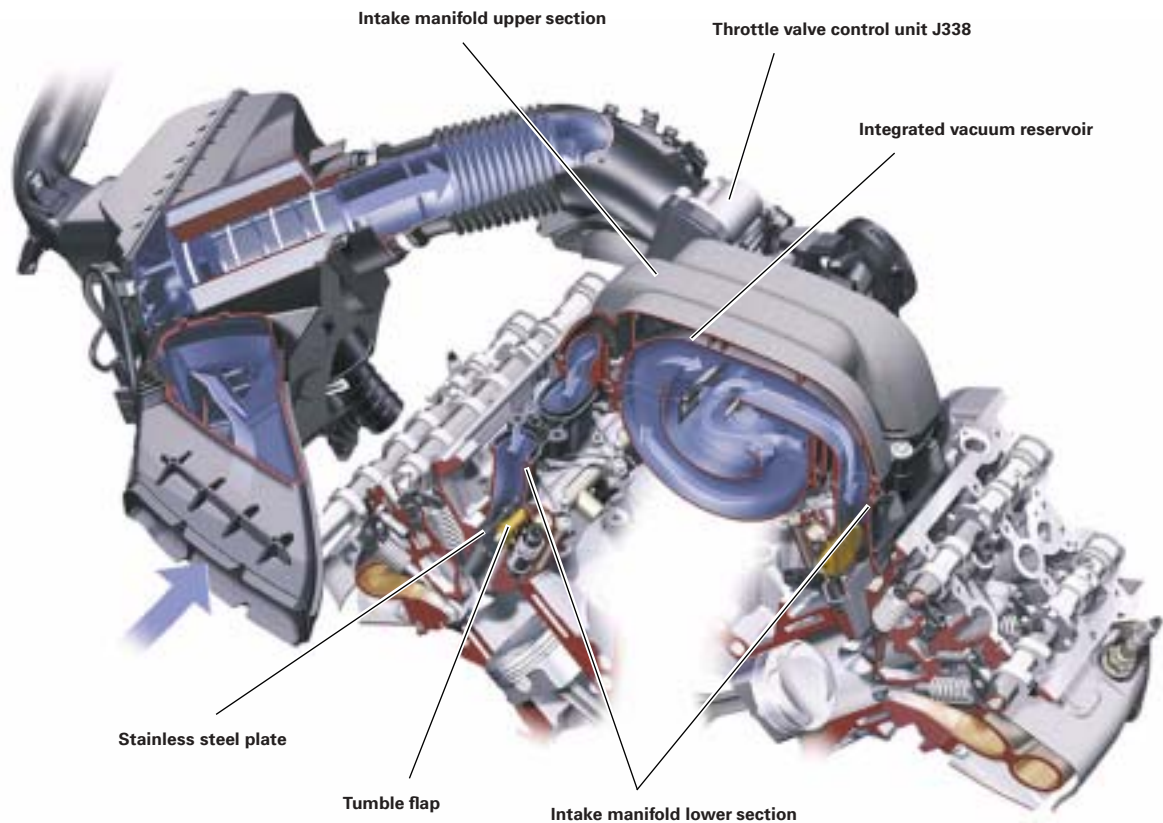

327_012

Tumble flaps

The tumble flaps are housed in the intake port, which is split horizontally into two halves by means of an inserted stainless steel plate. The tumble flaps seal the lower part of the intake port, depending on the required flow intensity. Intensifying the air flow causes the air column within the combustion chamber to "tumble", thus optimising the swirl conditions for air-fuel mixture preparation.

The tumble flaps are vacuum operated via the Simos control unit, which recognises the left-hand flap position via intake manifold flap potentiometer 2 G512 and the right-hand flap position via intake manifold flap potentiometer G336.

3.2-litre V6 FSI engine

Oil circuit

Description

The pressurised circulating lubrication system is driven by an internal-gear wheel oil pump (Duocentric) with an oil strainer on the inlet side. The oil pump is located in the oil sump. A pressure relief valve operating in parallel provides overload protection (11 bar >) for the oil cooler and oil filter in the cold-running phase at low ambient temperatures.

The cylinder heads are supplied with oil via two separate risers per cylinder head. The first riser supplies the pivot element with hydraulic clearance compensation and the camshaft bearing. The second riser supplies the tensioners for the camshaft timing chains and the camshaft adjusters.

The separate risers isolate the cylinder head supply from the pulsation caused by the dynamics (changes in volume) of the camshaft adjuster and the chain tensioner.

When the engine is running, the oil temperature and oil level are monitored by the oil level/oil temperature sender G266. The sender is integrated in the bottom section of the oil sump.

The oil pressure retaining valves ensure that enough oil is present in the cylinder head and that proper lubrication is provided as quickly as possible after the engine is started.

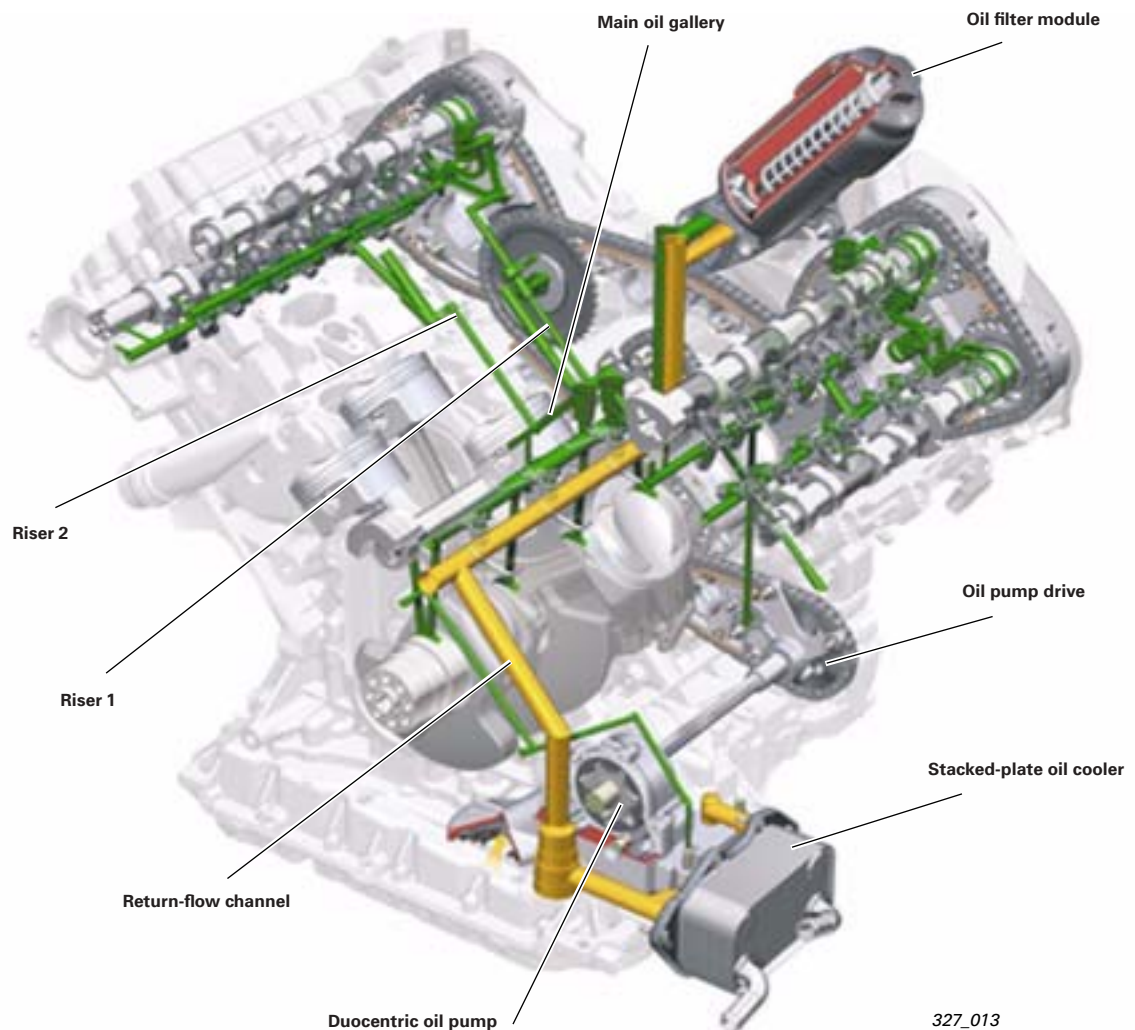

327_013

Cooling system

Cooling circuit

The conventional coolant pump is accommodated in the V of the central crankcase. The pump is driven by a ribbed V-belt.

The coolant flows via the cylinder crankcase to the water jackets in the engine.

To maximise cooling efficiency at the cylinder heads, coolant flows diagonally through the cylinder heads from the outlet side.

The coolant thermostat is located adjacent to the coolant pump in the cylinder crankcase, resulting in short flow paths during short circuit operation.

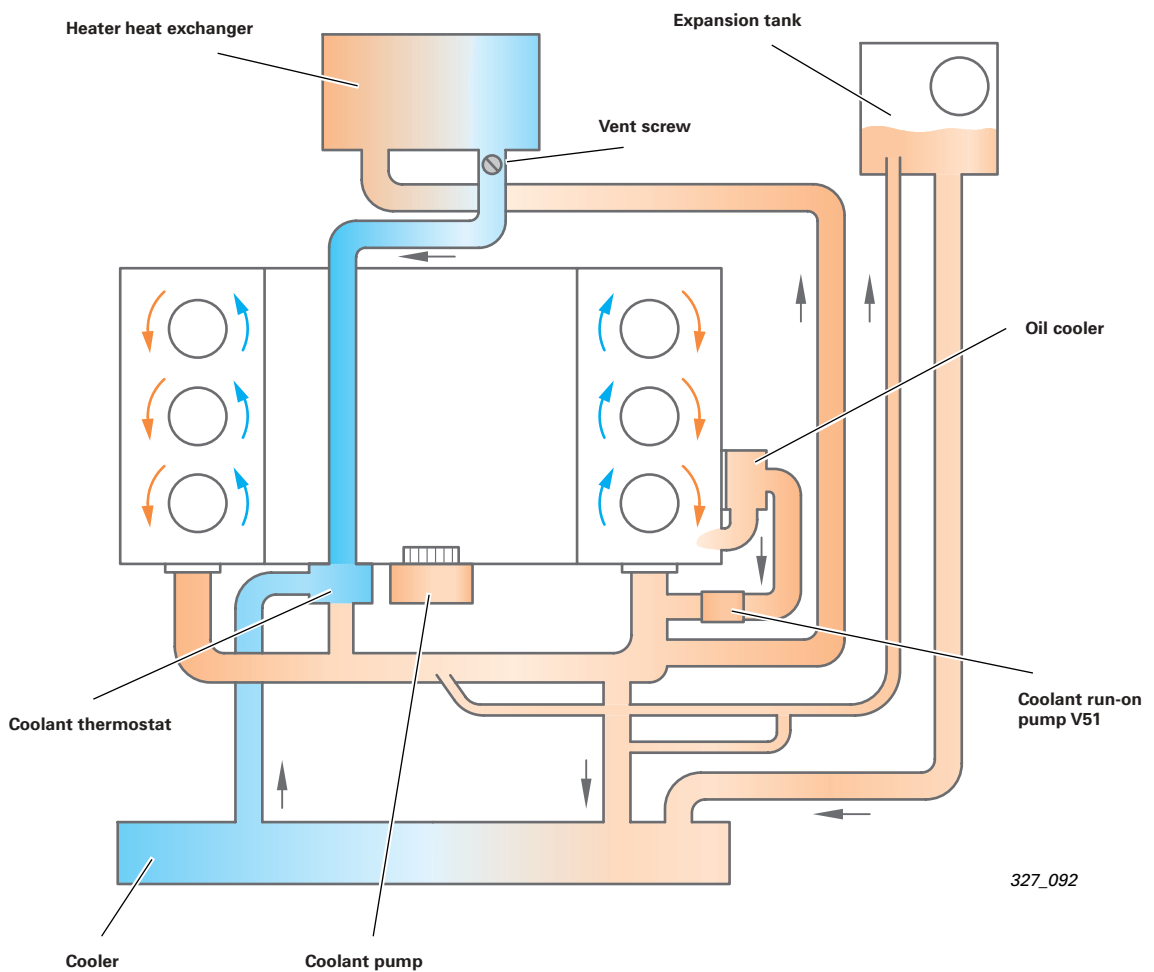

327_092

3.2-litre V6 FSI engine

Petrol direct injection system with supply on demand fuel system

Fuel supply system

The fuel supply system consists of the low and high pressure systems.

The low-pressure system consists of:

- the fuel supply unit
- the fuel filter and
- the fuel lines

The high-pressure system consists of:

- the high-pressure fuel rail
- the pressure sensor
- the pressure limiting valve
- the high-pressure fuel injection pump
- the high-pressure fuel lines and
- the high-pressure injectors

Low-pressure system

The fuel pump control unit J538 adjusts the fuel pressure in the low-pressure system on demand and is activated by the Simos control unit J361 using a pulse-width modulated (PWM) signal. Control unit J538 activates the fuel pump (pre-supply pump) G6 via an additional pulse-width modulated signal.

The fuel pressure sender, low pressure monitors the fuel pressure and sends an electrical signal to the Simos control unit.

The Simos control unit is thus able to gauge the current fuel pressure and modify the PWM signal as required, enabling the fuel pressure to be increased or decreased.

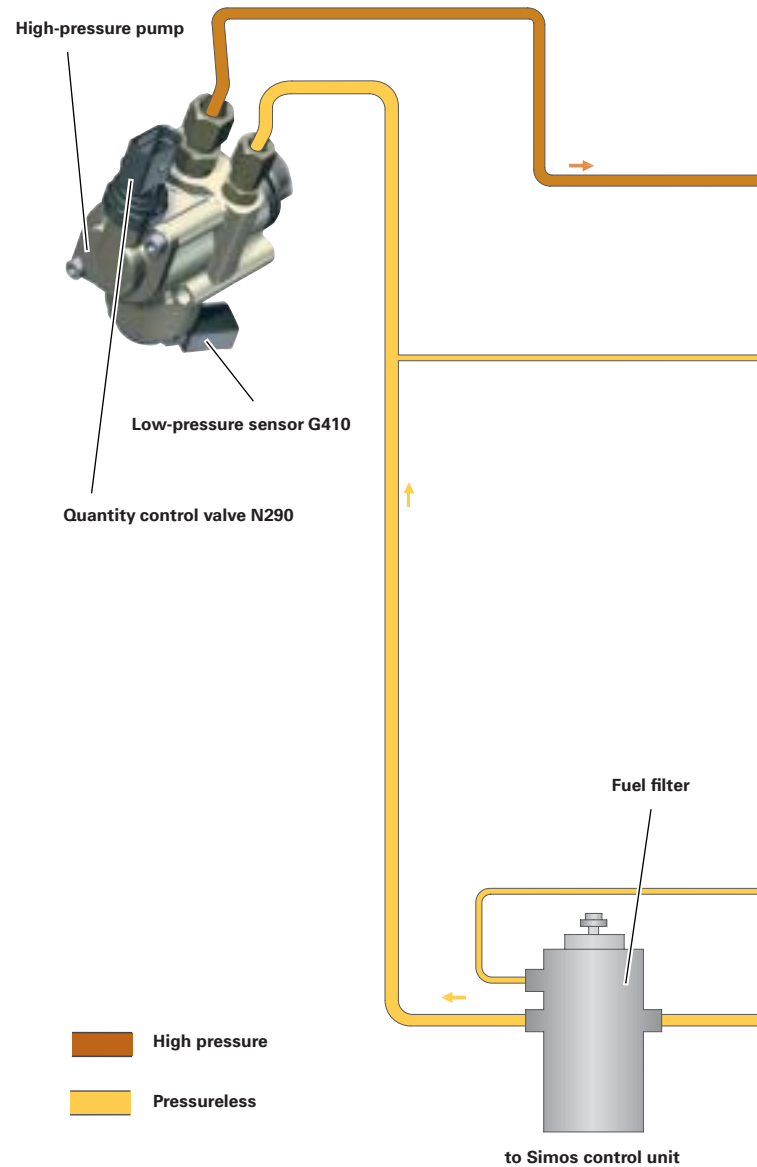

High-pressure system

The fuel pressure in the high-pressure system is developed by the single-piston high-pressure pump. The pump is driven mechanically by a single three-lobe cam located at the end of the cylinder bank 2 intake camshaft. The fuel metering valve N290 integrated in the pump regulates the fuel pressure within the range from 30 – 100 bar. The pump is activated by the Simos control unit.

The Simos control unit monitors the pressure in the high pressure system via fuel pressure sender G247.

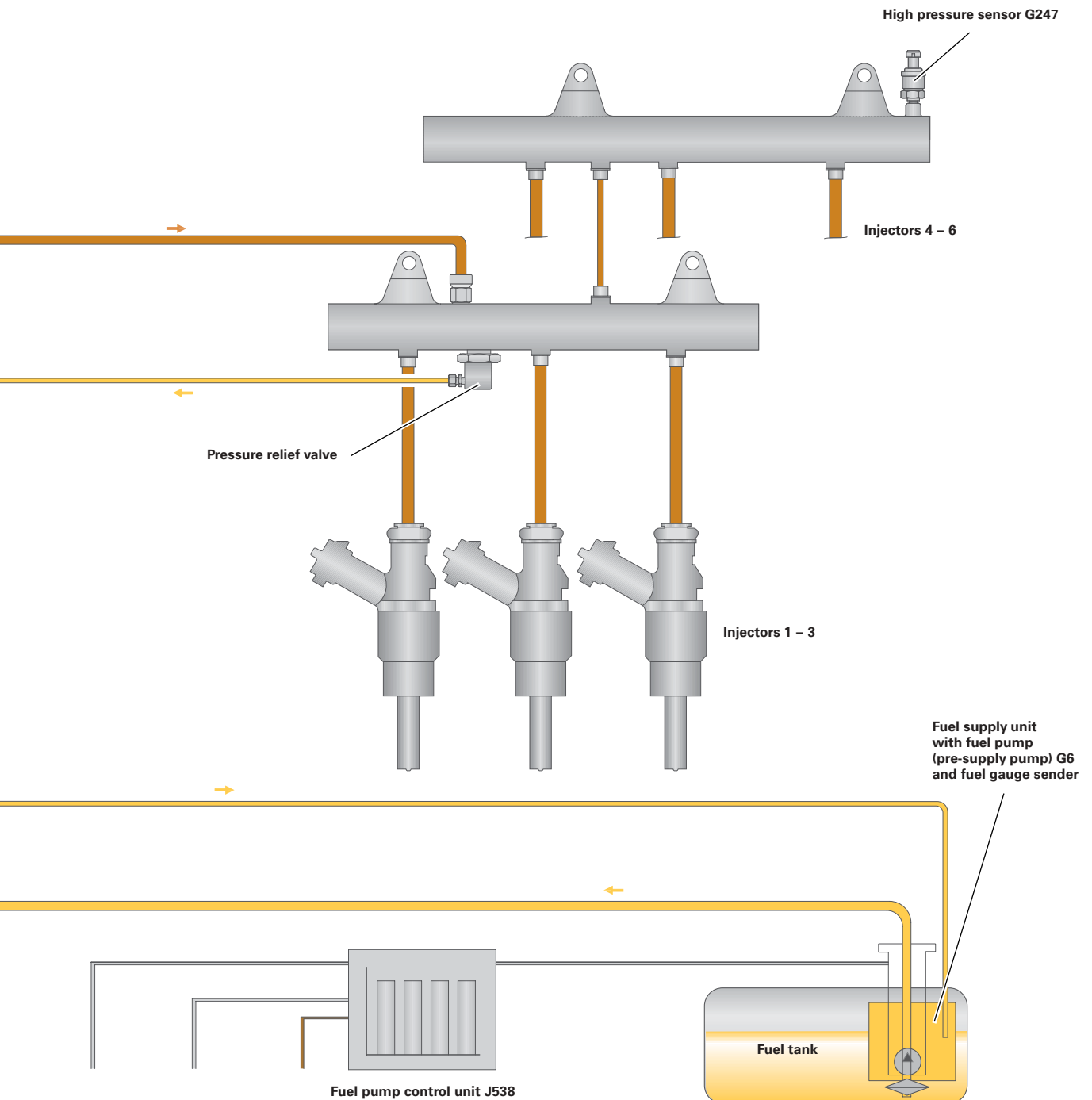

327_014

3.0-litre V6 TDI engine

Description

Technical features

- Camshafts driven by timing chains
- Timing chain on the transmission side
- Backlash compensation between the exhaust and intake camshafts
- Balancer shaft rotating at engine speed, to compensate for crankshaft vibrations
- Intake manifold with swirl flaps
- Electrically adjustable VTG turbocharger
- Common rail diesel direct injection
- High-pressure pump drive via toothed belt
- Piezoelectric injectors
- Dual-circuit cooling system
- Oil circuit with Duocentric oil pump and cold start valve
- Oxidation catalytic converter with lambda control
- Additive-free particulate filter (optional) (Catalysed Soot Filter)



327_003

Reference

For further information, please refer to SSP 325, AUDI A6 '05 - Ancillaries.



Performance features

Engine code, torque and power output

The engine code is located at the front left under the toothed belt for driving the high-pressure pump.



327_015

Torque/power curve

- Max. torque in Nm
- Max. power output in kW

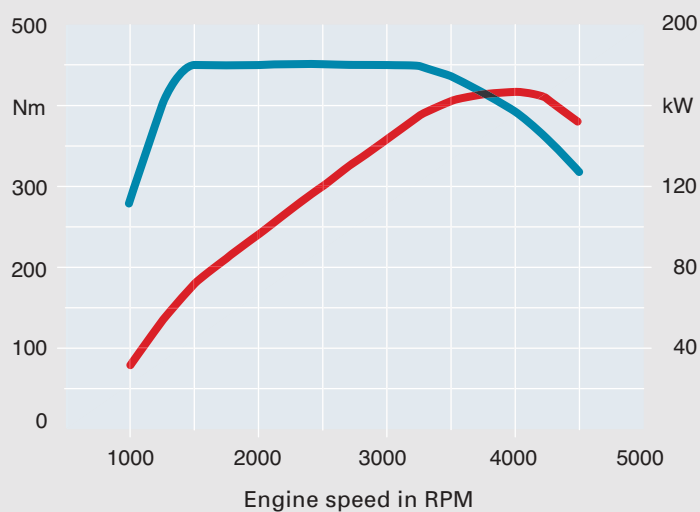

Specifications

Engine code	ASB
Type of engine	6-cylinder vee-engine with 90° angle
Displacement in cm ³	2967
Max. power output in kW (bhp)	165 (224) at 4000 RPM
Max. torque in Nm	450 at 1500 RPM
Number of valves per cylinder	4
Bore in mm	83
Stroke in mm	91.4
Compression ratio	17 : 1
Firing order	1-4-3-6-2-5
Fuel grade	Diesel, at least CN 51
Exhaust emission control	Oxidation catalytic converter with lambda control, optional particulate filter
Engine management	Bosch EDC 16 CP (common rail)
Exhaust emission standard	EU IV

3.0-litre V6 TDI engine

Chain drive

Driven camshafts, oil pump and balancer shaft

The short dimensions of the Audi vee-engines combined with the compact two-piece chain drive on the transmission side have made it possible to limit engine length to 444 mm despite the widening of the cylinder spacings from 88 mm to 90 mm.

The chain drive comprises four simplex chains arranged in two planes. They drive the camshafts of the left and right banks of cylinders, the oil pump and the balancer shaft.

The four simplex chains are divided into pinion gears A, B, C and D.

The chains are driven by the crankshaft, which connects to chain drive A, which connects to the idler gears, which drive the camshafts via chain drives B and C.

The necessary reduction ratio between the crankshaft and the camshaft is provided by the idler gears.

The oil pump and the balancer shaft are driven by the crankshaft via chain drive D.

Hydraulic chain tensioners with built-in non-return valves are used to tension the chains.

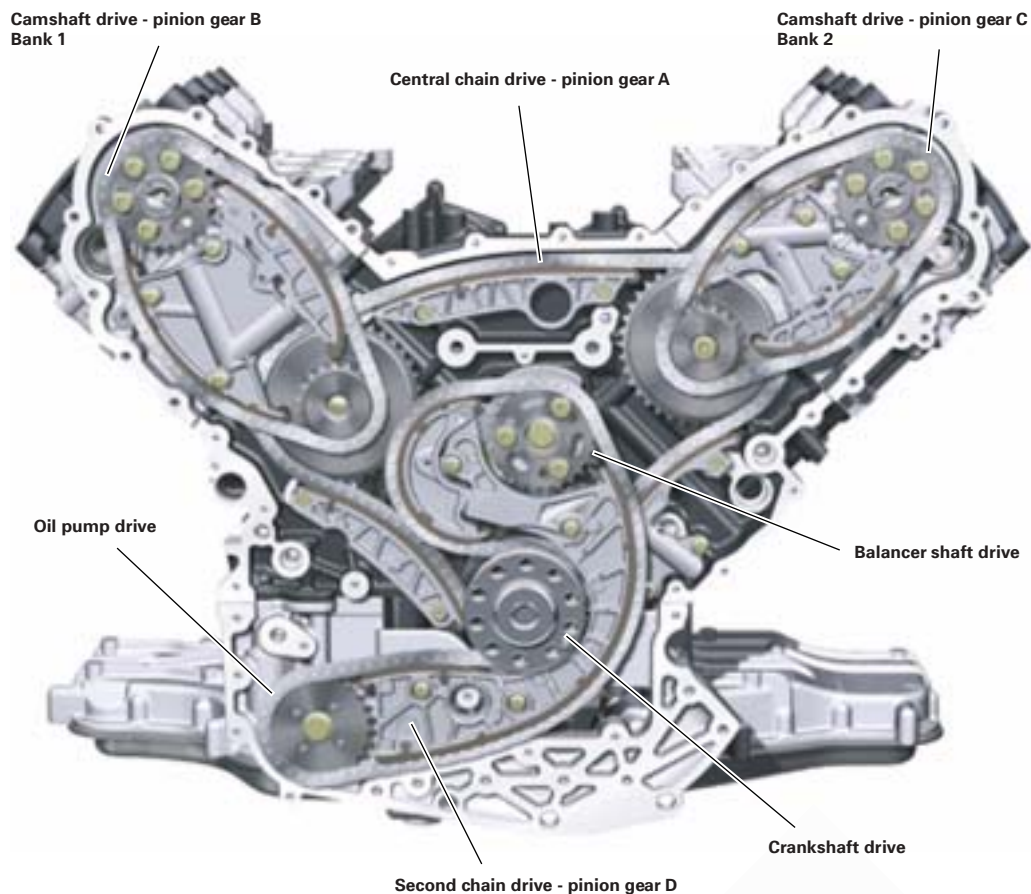

327_042

Balancer shaft

Engine vibrations are compensated by the balancer shaft. The balancer shaft is driven by chain drive D and counter-rotates relative to the engine at the same speed as the engine. The balancer shaft is installed in the vee of the engine.

The unique feature of this configuration is that the balancer shaft is guided by the engine and the balance weights are located on the engine side opposite the drivetrain.

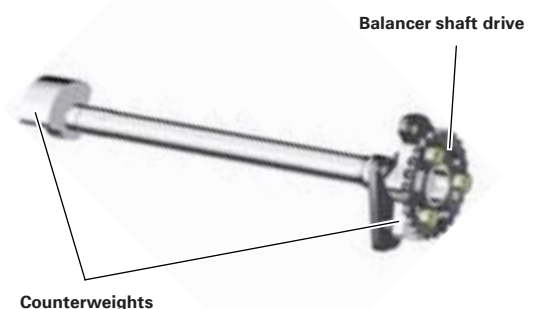

327_043

Backlash compensation

Spur gear

The spur gear of the respective exhaust camshaft is split in two to compensate for backlash between the intake and exhaust camshafts of each bank of cylinders.

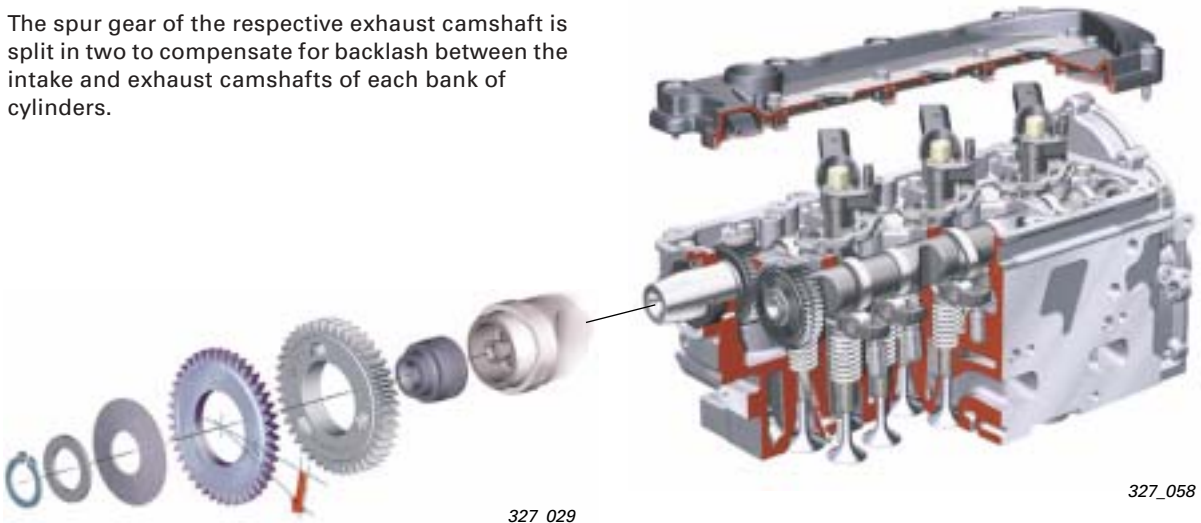

The wider part of the spur gear is shrink-fitted onto the camshaft. The narrower part of the spur gear is attached to the camshaft by a circlip and pressed against the wider part by the diaphragm spring.

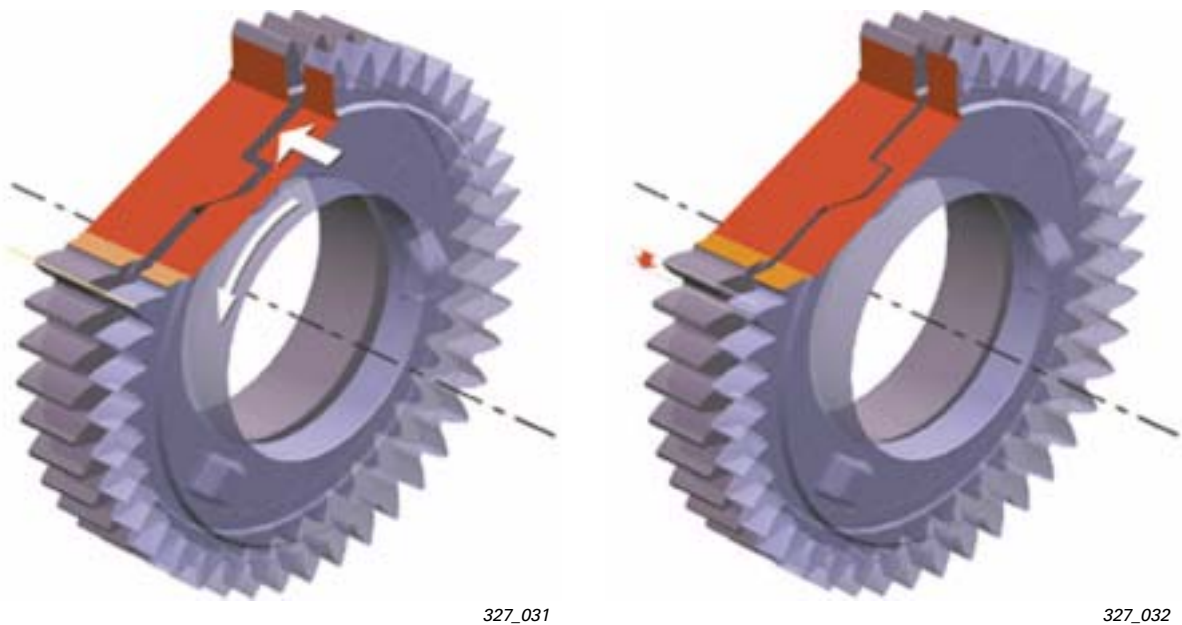

Tooth backlash compensation

The diaphragm spring presses (axial force) the narrower part of the spur gear against the wider part with a defined force, with the result that the three ramps on the wider part of the spur gear are pressed into the three recesses in the narrower part. Due to the shape of the ramps and recesses, the two parts of the spur gear counter-rotate in relation to each other, resulting in an offset between the teeth and compensating for backlash.

3.0-litre V6 TDI engine

Intake manifold

Swirl flap

Adjustable swirl flaps are incorporated into the intake manifold. The flaps are adjusted by the electrical swirl flap adjuster. They enable the airflow to be adjusted to suit engine speed and load. Not only additional power and torque result, but also lower fuel consumption and emissions.

The electrical swirl flap adjuster is activated by the engine control unit, which is notified of the momentary position of the swirl flap by a potentiometer integrated in the swirl flap adjuster.

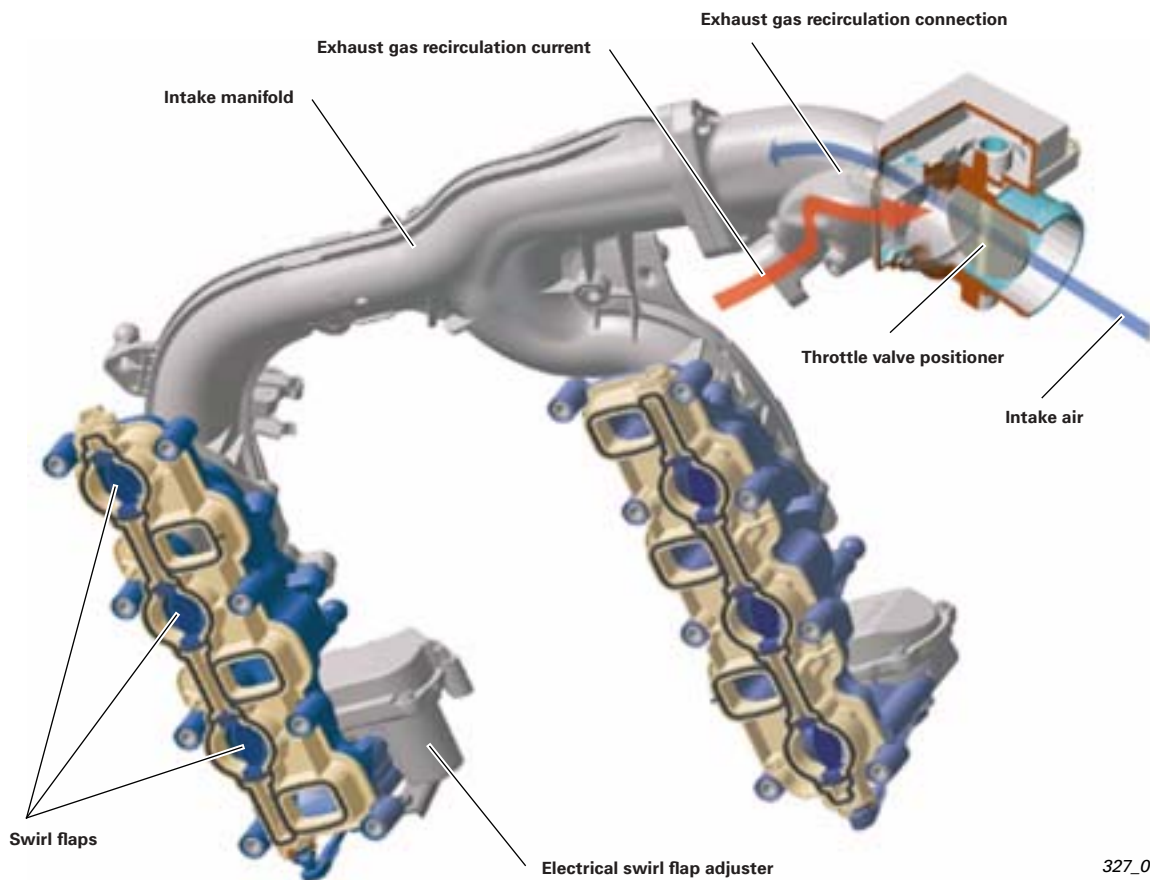

327_033

Throttle valve positioner

To reduce the compression effect and ensure a smooth engine shutdown, the throttle valve positioner is closed when the engine is shut down. When the engine is running, the opening and closing of the throttle valve positioner are map-controlled. As a result, the exhaust gas recirculation rate is regulated.

Charging

Electrically adjustable turbocharger with variable turbine geometry (VTG)

The 3.0-litre V6 TDI engine has a variable turbine geometry (VTG) turbocharger. The guide vanes in the turbocharger are adjusted by the turbocharger control unit. This provides enhanced turbocharger response and optimised boost pressure in all RPM ranges. The turbocharger control unit is activated by the engine control unit.

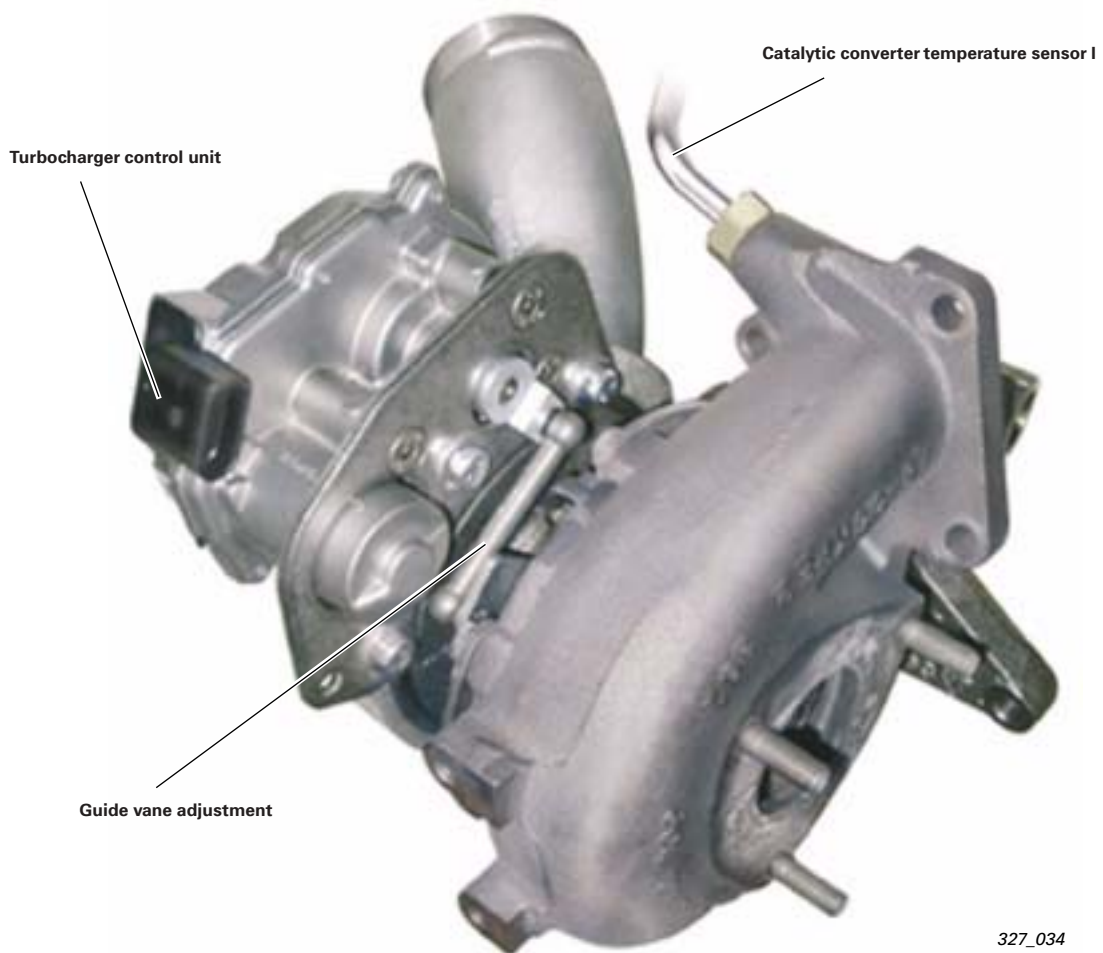

Temperature sender

Catalytic converter temperature sensor I measures the charge air temperature. With this data, the turbocharger can be protected against overheating by the intervention of the engine control unit.

3.0-litre V6 TDI engine

Fuel system

The 3rd generation common rail system performs fuel/air mixture preparation. The fuel system has a high-pressure circuit, a supply pressure circuit, a low-pressure return circuit from the injector and a return pressure circuit.

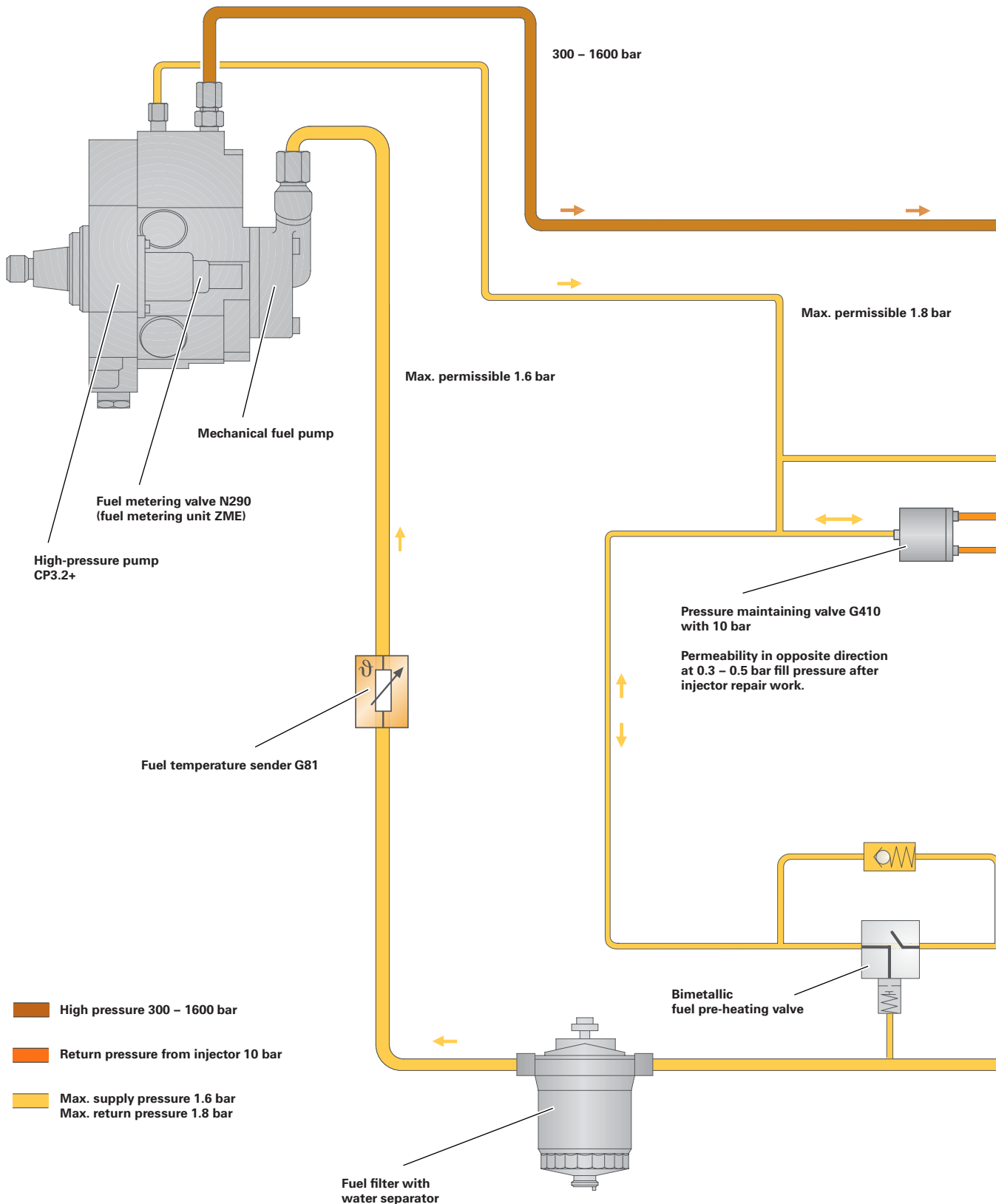

The maximum injection pressure is now 1600 bar, 250 bar higher than on earlier 2nd generation common-rail systems.

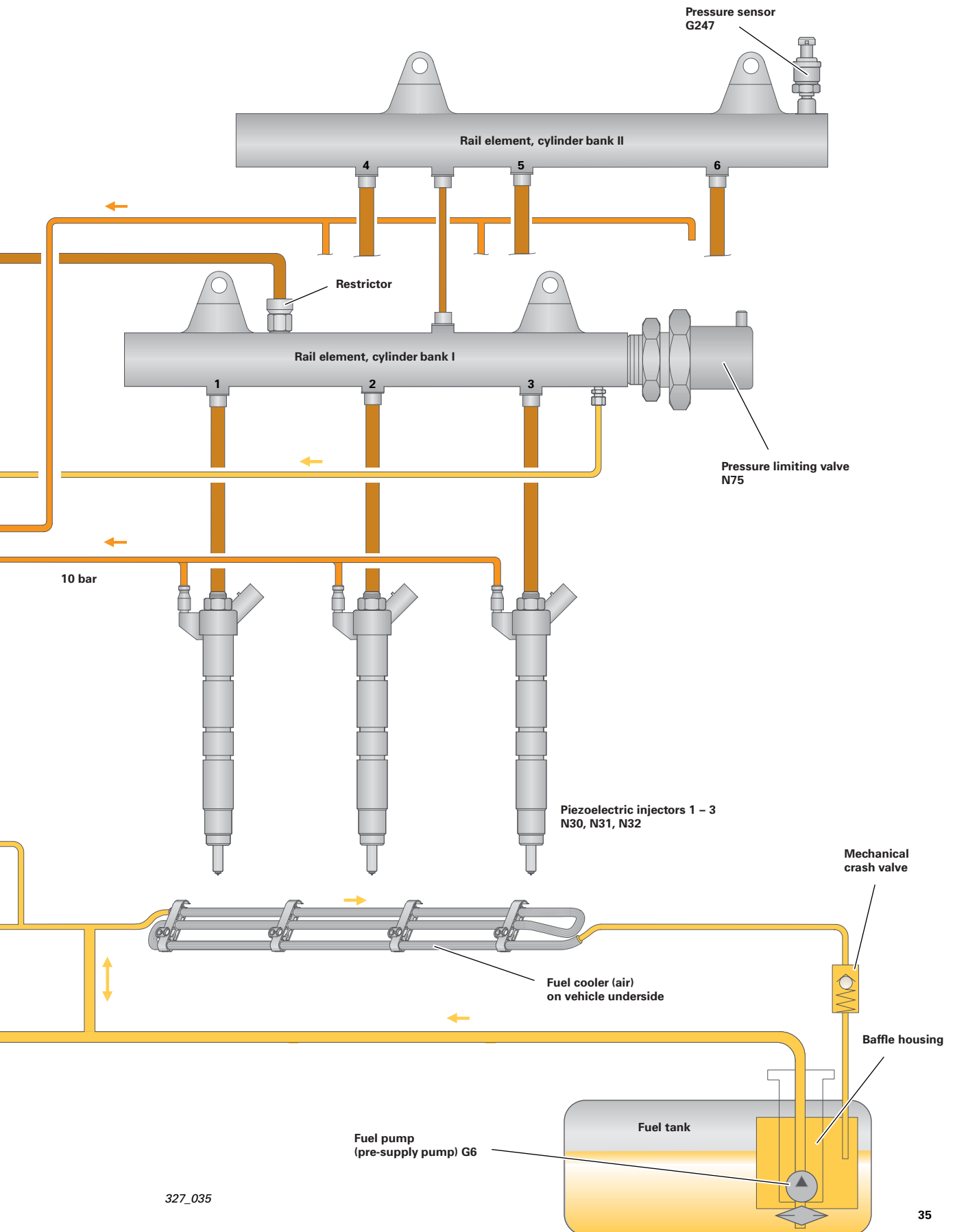

4.0-litre V8 TDI engine

Description

Technical features

- Camshafts driven by timing chains
- Timing chain on the transmission side
- Ancillary units driven by chains
- Toothed belt drive by means of a high-pressure pump
- Backlash compensation between the exhaust and intake camshafts
- Intake manifold with swirl flap
- Electrically adjustable VTG turbocharger
- Common rail diesel direct injection system
- Dual-circuit cooling system
- Oil circuit with Duocentric oil pump and cold start valve
- Oxidation catalytic converter with lambda probe

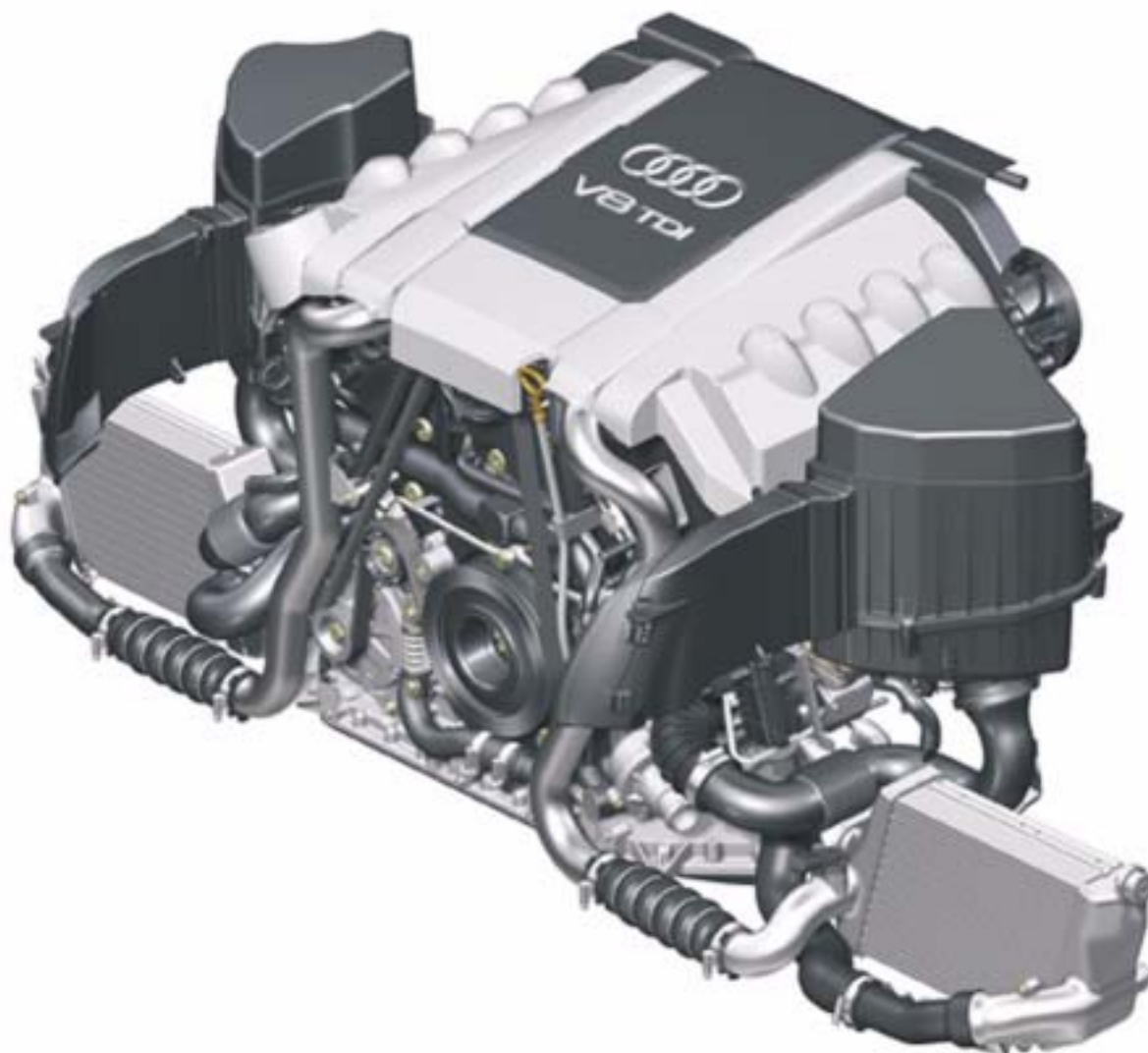

327_024

Performance features

Torque and power output

The engine code is located in the inner vee of the engine block on the left-hand side of the cylinder head.

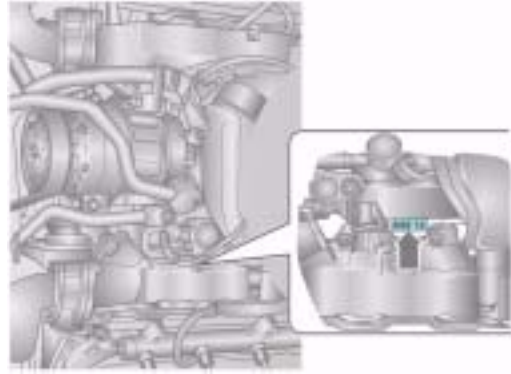

327_091

Torque/power curve

- Max. torque in Nm
- Max. power output in kW

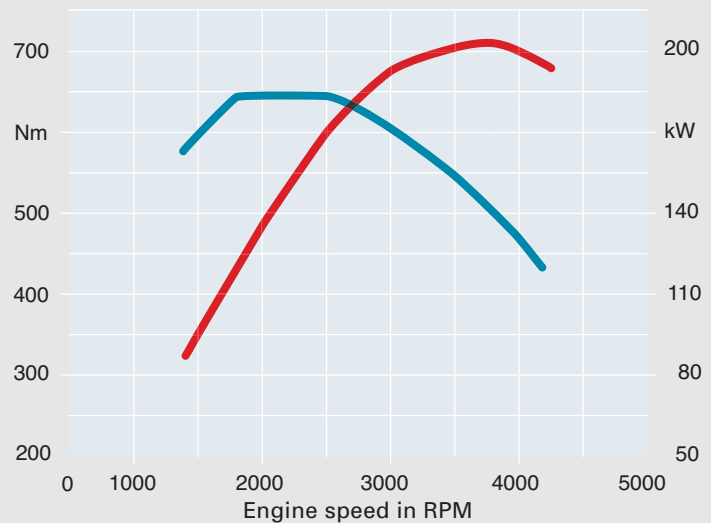

Specifications

Engine code	ASE
Type of engine	V8 TDI with two VTG turbochargers, DOHC
Displacement in cm ³	3936
Max. power output in kW (bhp)	202 (275) at 3750 RPM
Max. torque in Nm	650 at 1800 to 2500 RPM
Number of valves per cylinder	4
Bore in mm	81
Stroke in mm	95.5
Compression ratio	17.5 : 1
Firing order	1-5-4-8-6-3-7-2
Fuel grade	Diesel, at least CN 49
Exhaust emission control	Oxidation catalytic converter with lambda probes, water-cooled EGR, optional particulate filter
Engine management	Bosch EDC 16 C,
Exhaust emission standard	EU III

4.0-litre V8 TDI engine

Chain drive

Camshaft drive

The 4.0-litre V8 TDI engine has a four-piece chain drive arranged in two planes. The chain drive is located on the transmission side of the engine.

Chain drive A is the basic drive unit, which propels the camshaft chain drives B and C in the cylinder heads. Each of the intake camshafts is driven.

Chain drive D drives the ancillary units.

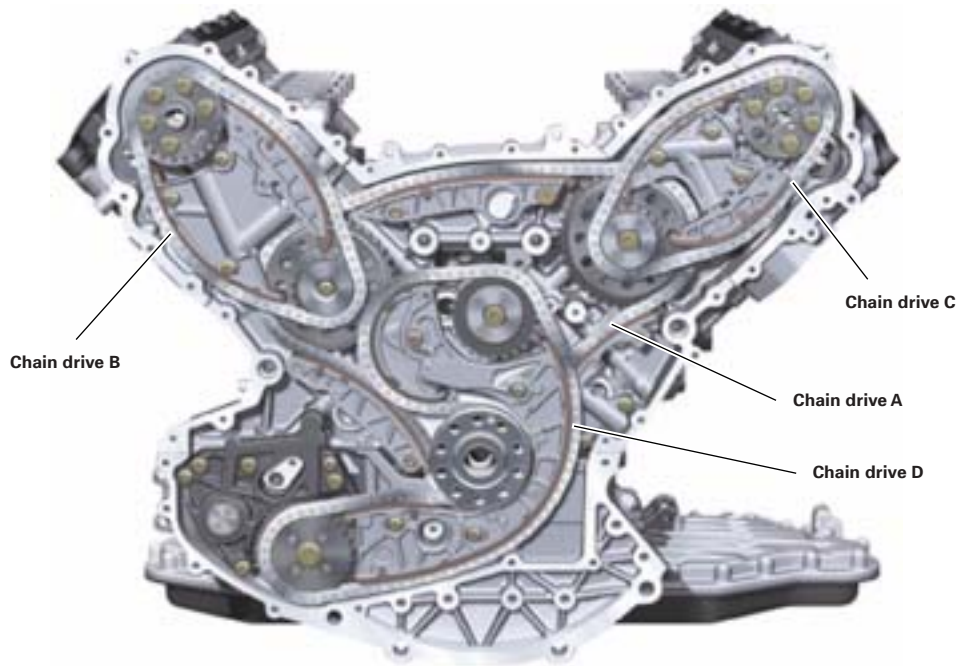

327_044

Ancillary units drive

Chain drive D drives the oil pump, the coolant pump and the power steering pump.

The gear module includes a ratio for coolant pump speed adjustment.

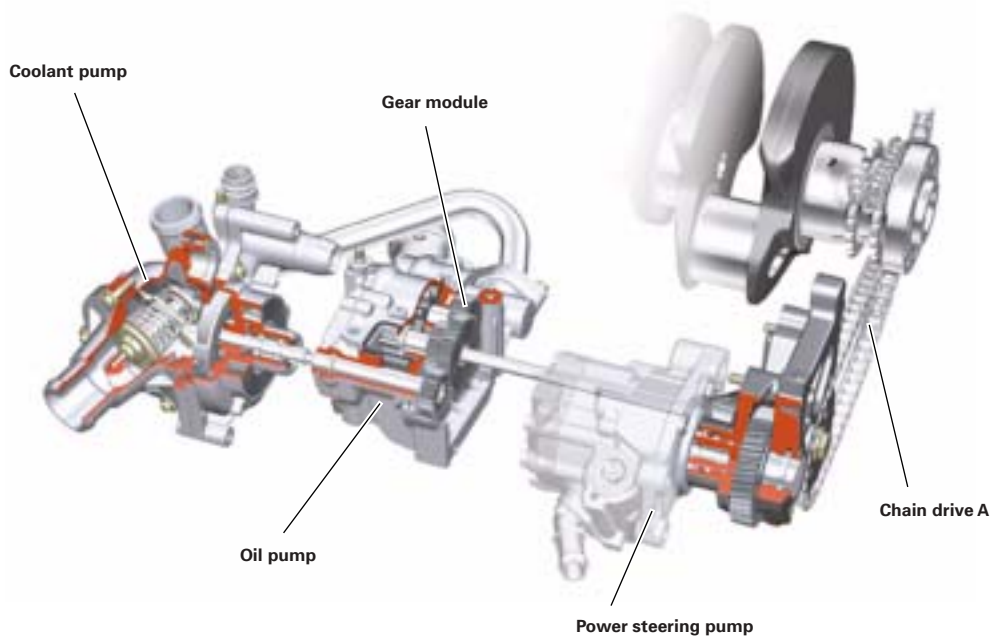

327_046

Engine lubrication

Oil circuit

The oil circuit has an external gear type oil pump which is shaft-driven by chain drive D.

The heat exchanger is incorporated into the inner vee of the engine. It is configured so that the oil temperature does not exceed 150 °C at maximum power output and in high ambient temperatures.

The oil filter is mounted in an upright position inside the inner vee of the engine and is readily accessible for servicing.

Crankcase ventilation

A three-cyclone oil mist separator is used to remove oil particles from the blow-by gases. The cyclone oil separator is located inside the inner vee of the engine.

The blow-by gases flow via the settling chamber and the three-cyclone oil mist separator - in which existing fine oil particles are separated - to the intake side of the turbocharger for the right-hand bank of cylinders.

The separated oil flows back into the oil sump through a port in the crankcase.

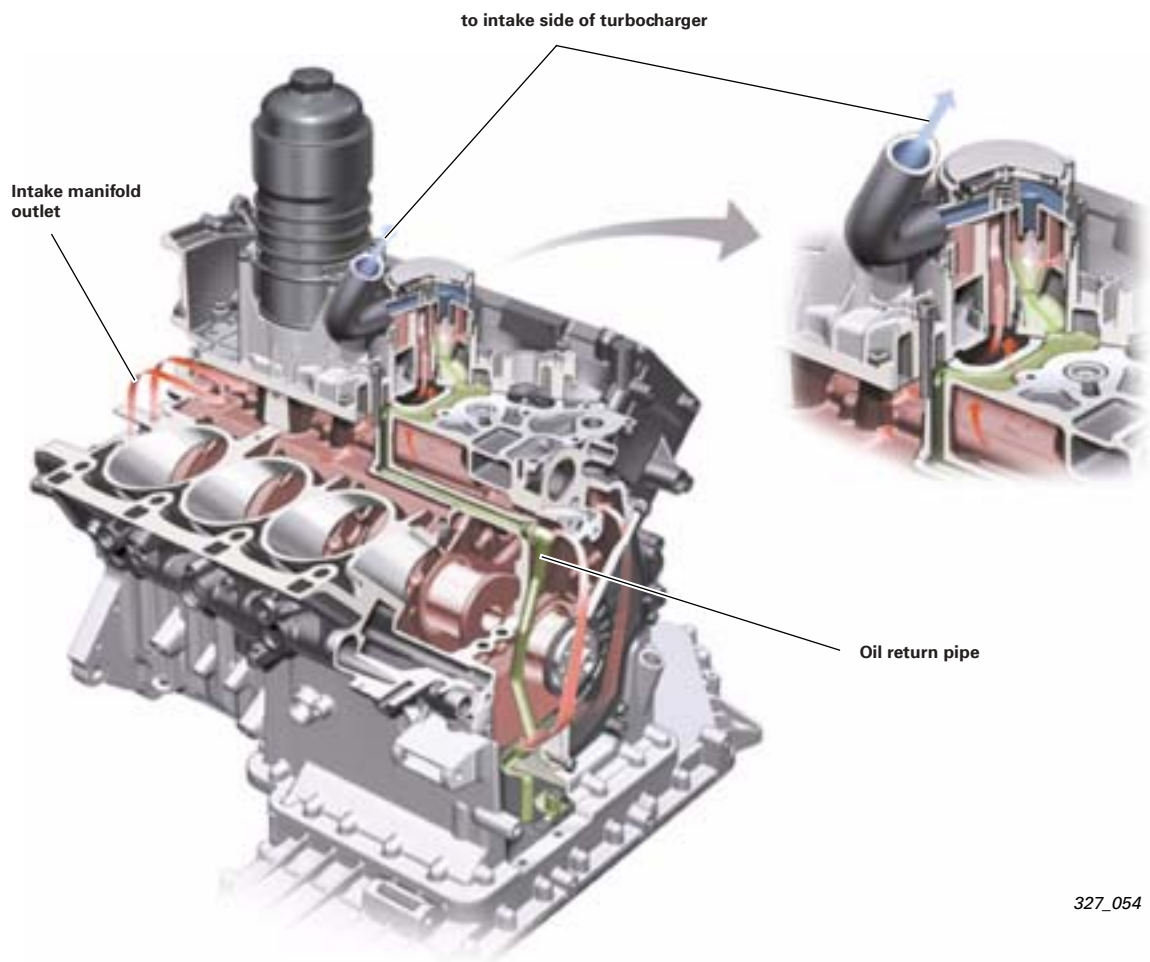

327_054

4.0-litre V8 TDI engine

Cooling system

Coolant circuit

The coolant flows through the crankcase and the cylinder head according to the cross-flow principle.

The coolant thermostat and the coolant pump are combined as a single unit and positioned at the front left-hand side of the engine. The coolant pump is driven by a stub shaft and a gear module via the oil pump from drive D.

The coolant pump has two outlets on the pressure side, each leading to a single bank of cylinders. Located on both sides of the cylinder crankcase are cast-on coolant distributor rails, where the coolant is admitted into the cylinder water jackets through four holes.

The crankcase coolant chamber is split lengthways into two halves. The main body of coolant is admitted into the cylinder heads, flows crosswise through the cylinder heads and returns to the crankcase on the inside of each bank of cylinders.

A smaller quantity of coolant flows directly from the pressure side to the intake side of the crankcase through vee-shaped holes in the cylinder webs. This is required to cool the throughflow areas.

In the main (larger) cooling circuit, the coolant from the cylinder banks and heat exchanger which has accumulated inside the crankcase circuit flows to the radiator. In the secondary (smaller) coolant circuit, the coolant flows directly to the coolant pump.

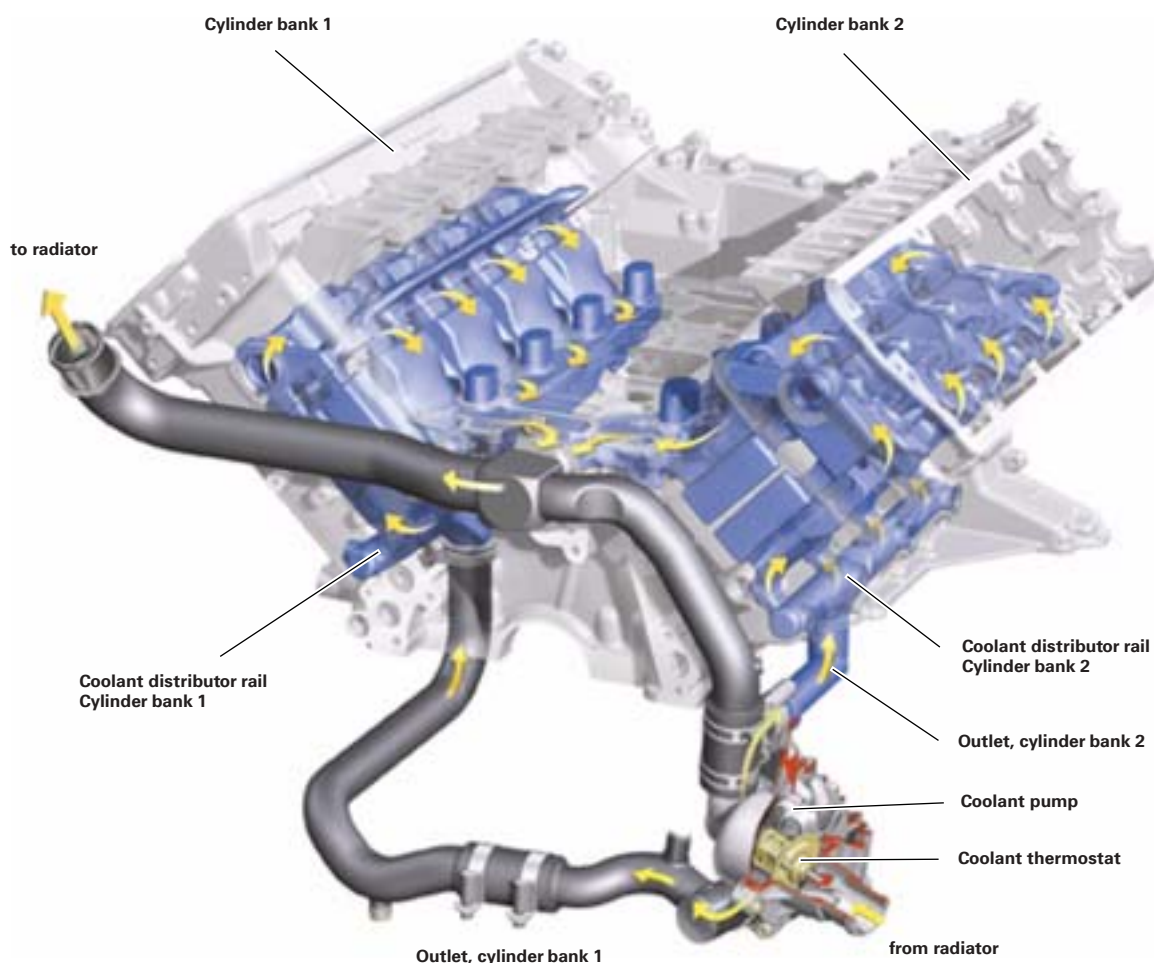

Air intake

Intake module

Air is induced through a double-chamber system with two air filters and two charge air intercoolers.

The two charge air intercoolers are located below the front headlights.

The intake manifolds and the pressure equaliser tube (for interconnecting the cylinder bank intake manifolds) are made from plastic to save weight and to reduce the friction of the intake air against the cylinder walls.

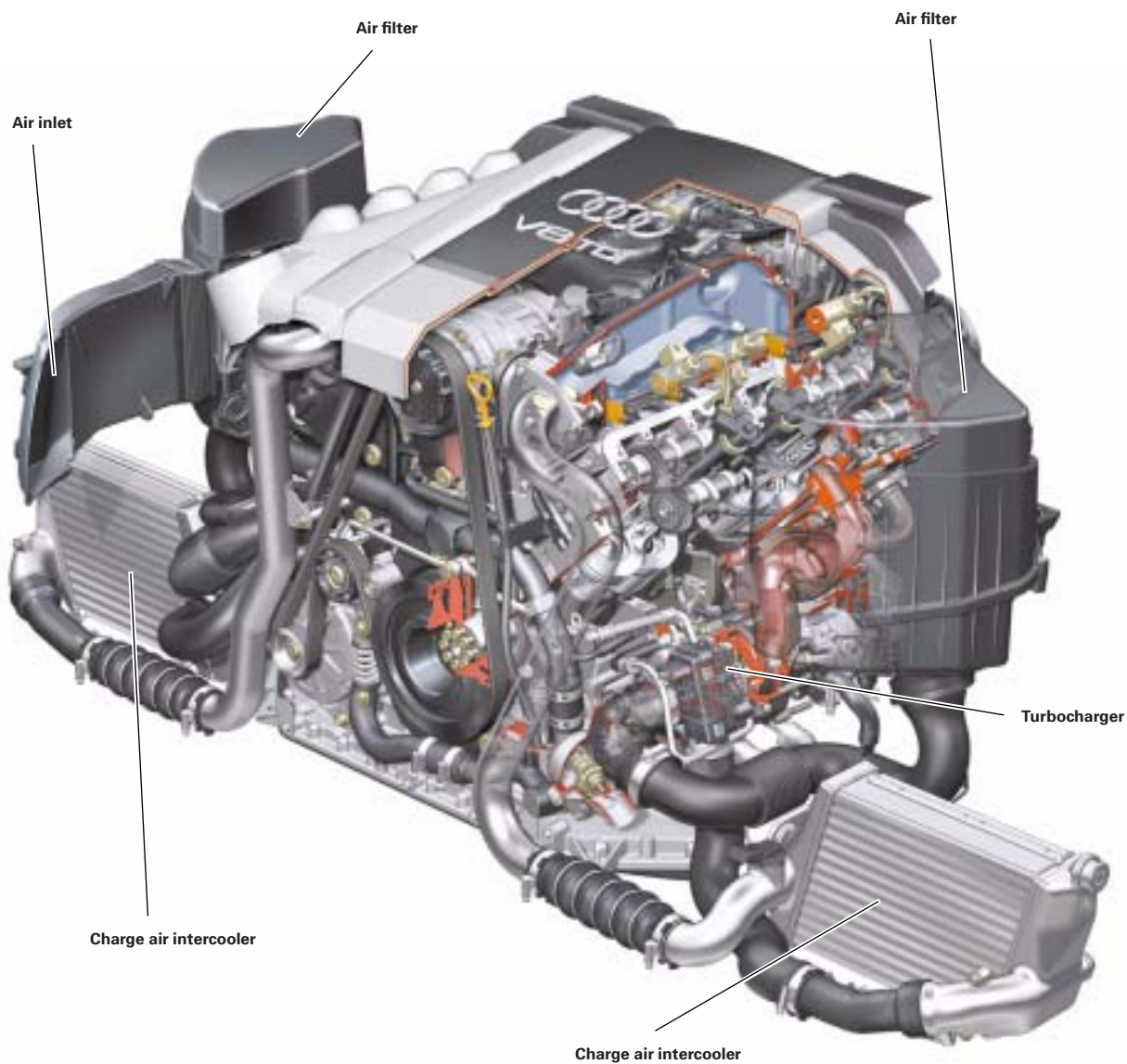

327_086

4.0-litre V8 TDI engine

Swirl flaps

The swirl flaps for shut-off of the helical inlet port at low engine speeds are located in the intake manifold.

The flaps are injected into the flap frame (lower section of intake manifold) using a special production method.

The 4.0-litre V8 TDI engine has a flap frame with a one swirl flap per cylinder for each bank of cylinders.

The swirl flaps in each bank of cylinders are operated by an electric motor (swirl flap adjuster) and a connection rod.

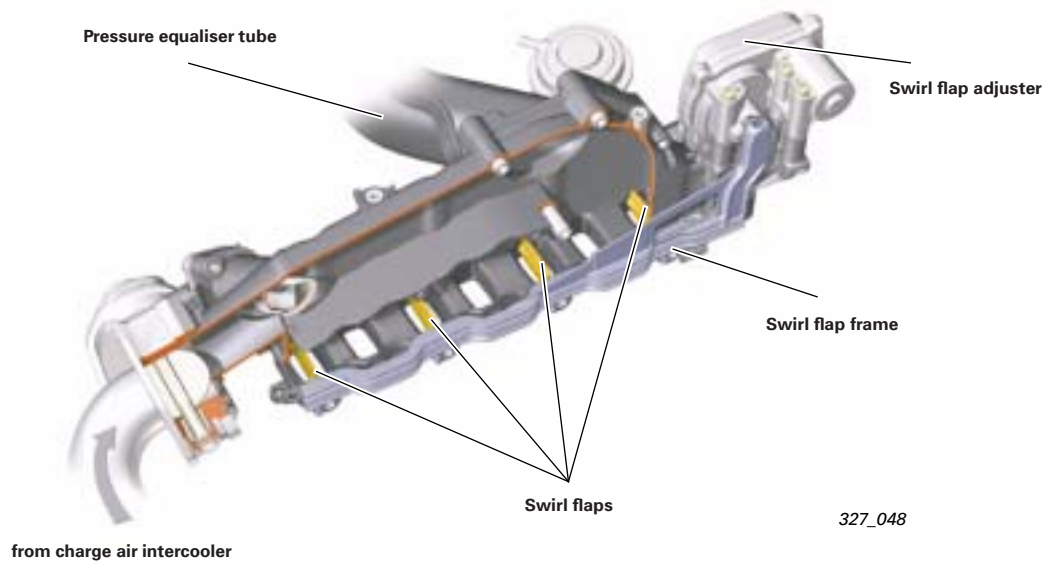

Swirl flaps closed

A closed helical inlet port in the lower RPM range provides improved torque and combustion efficiency.

Swirl flaps open

The helical inlet port is open in the mid and upper RPM ranges to maximise engine power output and combustion efficiency.

The swirl flaps can be in one of two positions: open or closed.

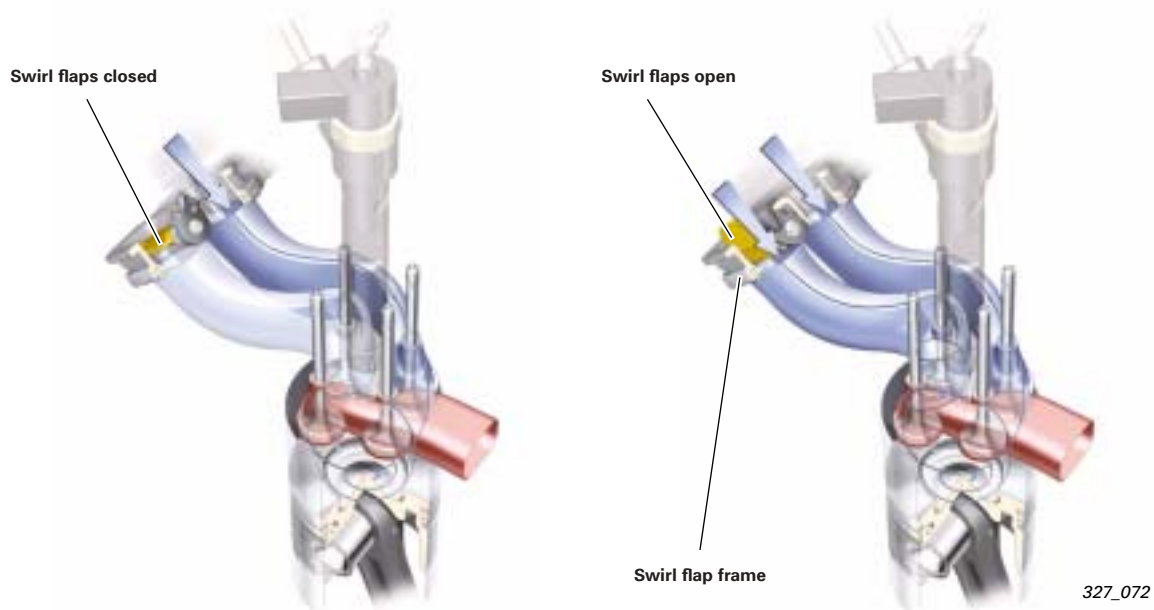

Fuel system

Injection system components

A second-generation common rail injection system which allows injection pressures up to 1600 bar is used. The system is configured similarly to the system used on the 3.3-litre V8 TDI engine.

The three-piston high-pressure pump and the fuel rail are incorporated into the inner vee of the engine.

The maximum permissible fuel temperature is maintained by using an under-vehicle fuel cooler and a low-temperature coolant-fuel heat exchanger. The heat exchanger is located below the high-pressure pump and is supplied by an electrical coolant pump via a separate circuit.

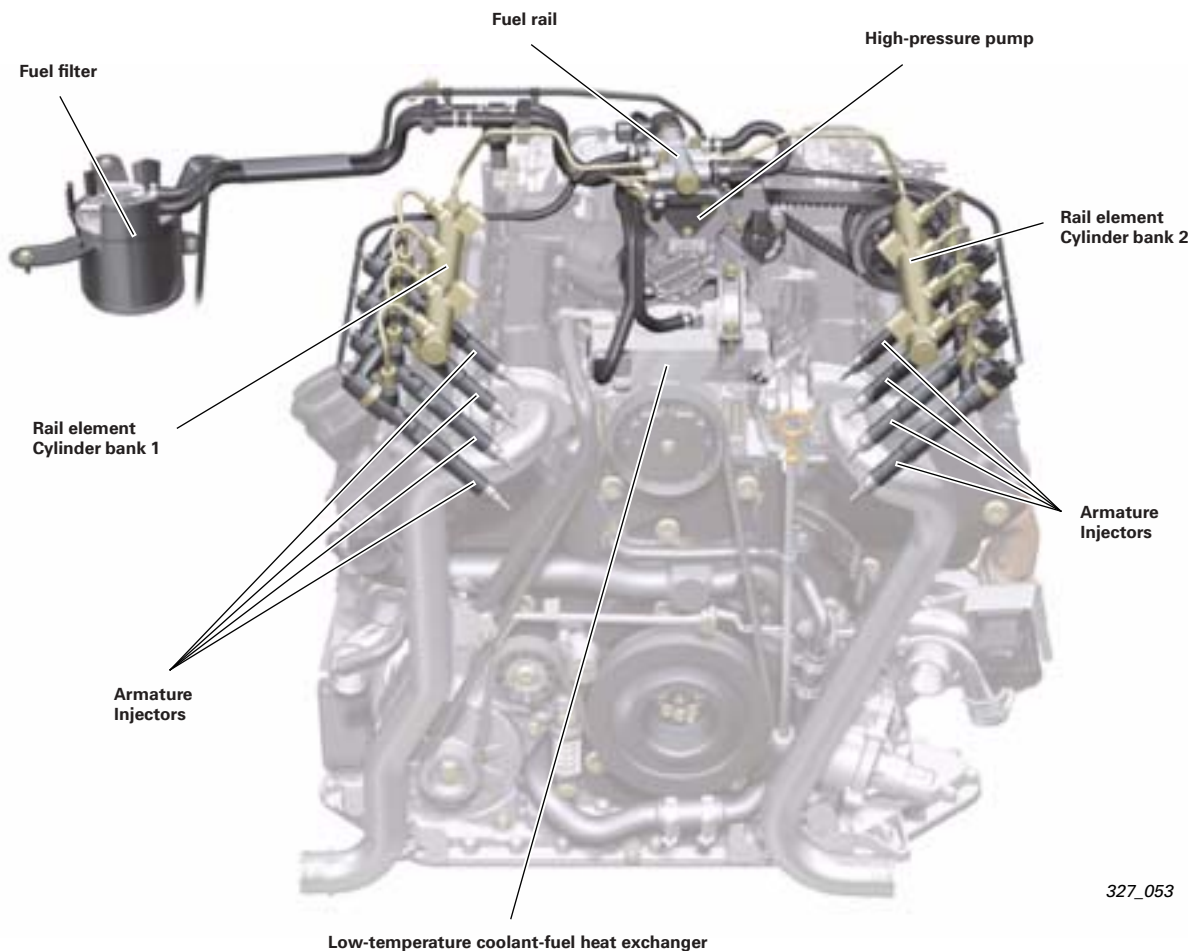

Reference



For a more detailed functional description of the fuel system, please refer to SSP 227 - The 3.3-litre V8 TDI common rail injection system.

Note



After replacing, each injector must be adjusted to the injection system. Please use the function "Guided Fault Finding" or "Guided Functions" on the Audi diagnostic systems.

4.0-litre V8 TDI engine

Charging

Exhaust manifold

The exhaust manifold is an air-gap insulated sheet-metal manifold. The turbochargers are mid-mounted below the exhaust manifolds. This spatial layout minimises exhaust gas heat losses due to the close proximity of the exhaust ports and turbochargers.

Electrically adjustable VTG turbocharger

The engine has two turbochargers with a variable turbine geometry. The following modifications were made to the turbochargers:

- Electrical actuator for enhanced response
- Coolant-filled central housing
- Exhaust gas temperature sensor
- Improved materials
- Improved bearings

With these modifications, the turbochargers meet the requirements for higher exhaust gas temperatures, boost pressures and turbocharger speeds, as well as extended oil change intervals.

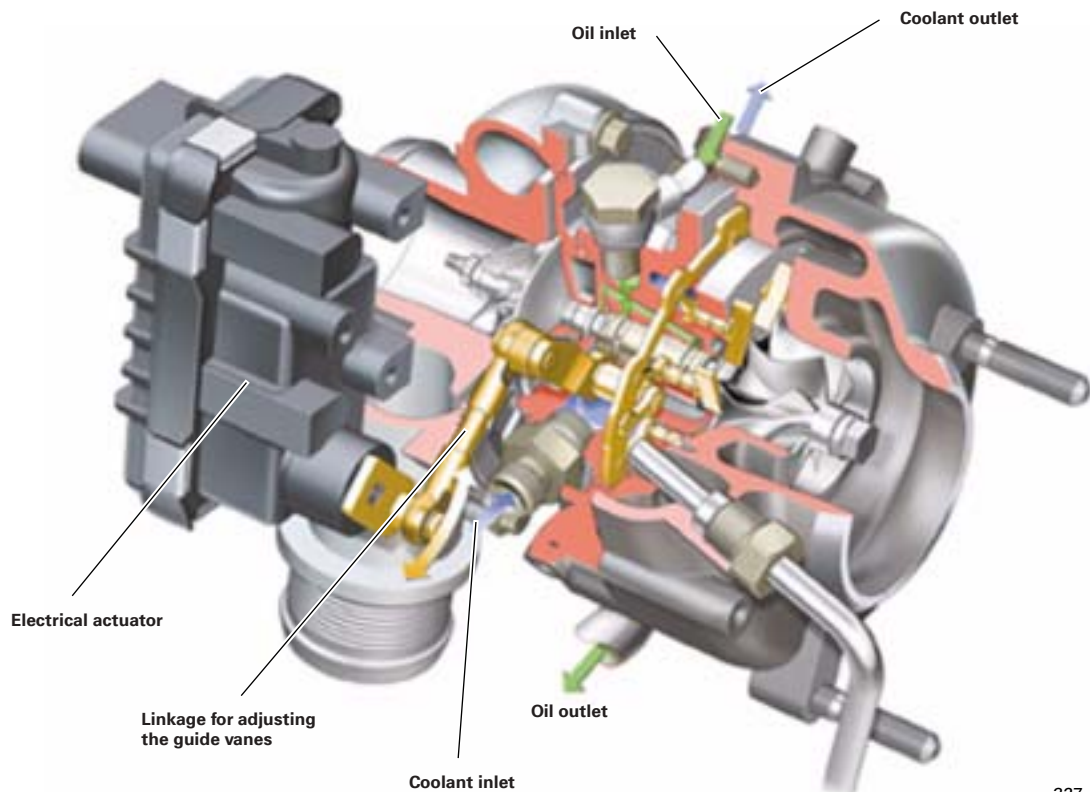

327_051

Exhaust system

Exhaust system

The exhaust system comprises

- pipe connections,
- air-gap insulated headpipes,
- two air-gap insulated exhaust manifolds,
- two primary catalytic converters and
- two main catalytic converters.

For emission control, oxidation catalytic converters are used in addition to the engine-specific modifications.

The exhaust system is double-chambered and the primary catalytic converters are positioned close to the engine so they reach operating temperature very quickly.

The two main catalytic converters are located in the underbody area.

Exhaust gas recirculation (EGR)

Exhaust gases from the two banks of cylinders are recirculated separately. Exhaust gas is extracted from the exhaust manifold at the rear cylinder in each bank of cylinders. The exhaust gas flows into the intake manifold through ports cooled by the engine coolant.

The necessary units (EGR valves, EGR cooler) for exhaust gas recirculation control are incorporated into the inner vee of the engine. The exhaust gas recirculation rate is controlled by two lambda probes.

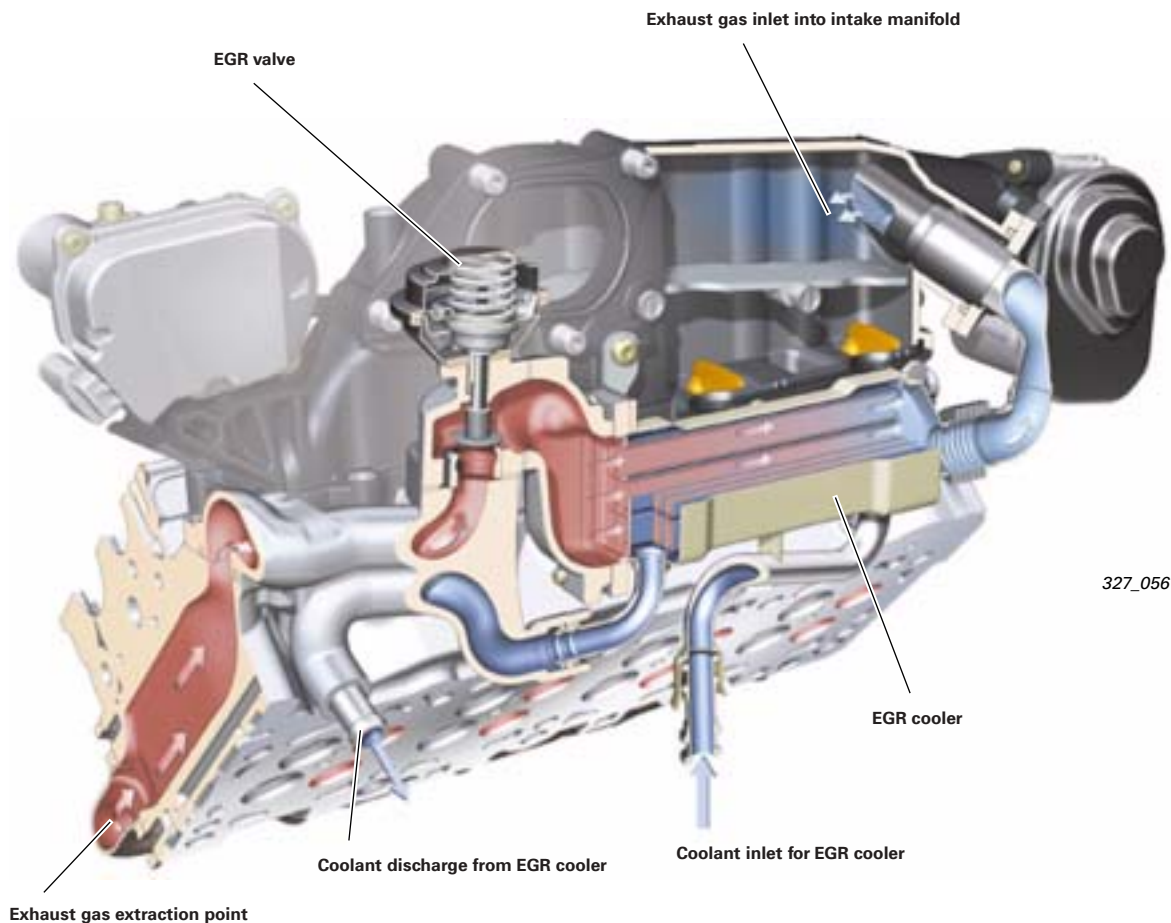

4.2-litre V8 engine

Description

Technical features

- Camshafts driven by timing chains
- Timing chain on the transmission side
- Ancillary units driven by chains
- Continuous intake camshaft adjustment
- Two-stage intake manifold
- Bosch ME 7.1.1 engine management system
- Dual-circuit cooling system
- Oil circuit with Duocentric oil pump
- Closed-loop catalytic converters with lambda control and secondary air system
- Air-gap insulated, highly heat resistant sheet-metal manifold

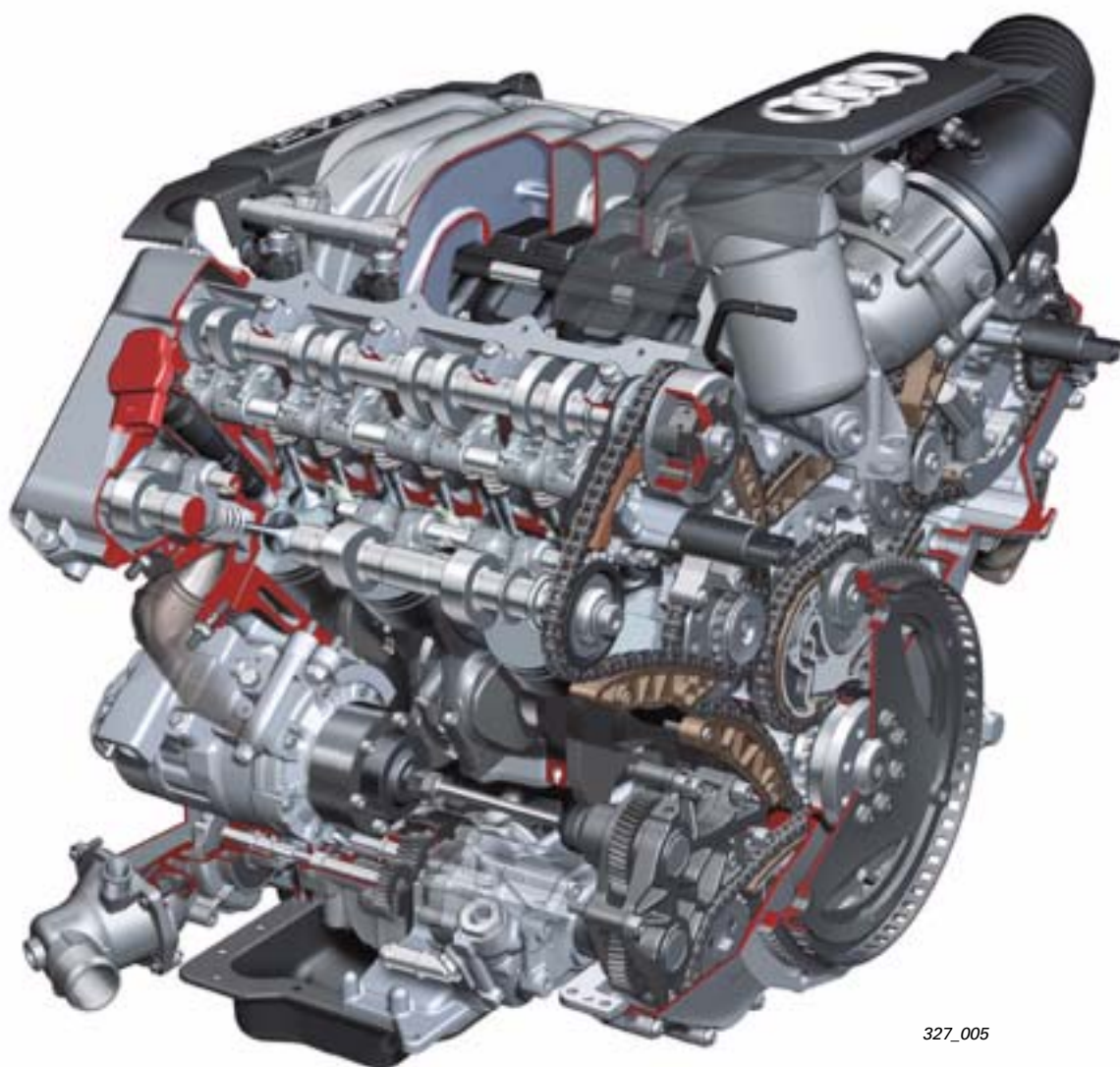

327_005

Reference

For further information, please refer to SSP 217 - The V8 5V engine.



Performance features

Torque and power output

The engine code can be found in the inner vee of the engine block, on the end face above the belt pulley.

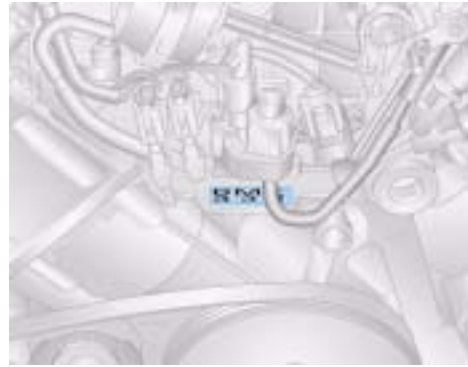

327_076

Torque/power curve

- Max. torque in Nm
- Max. power output in kW

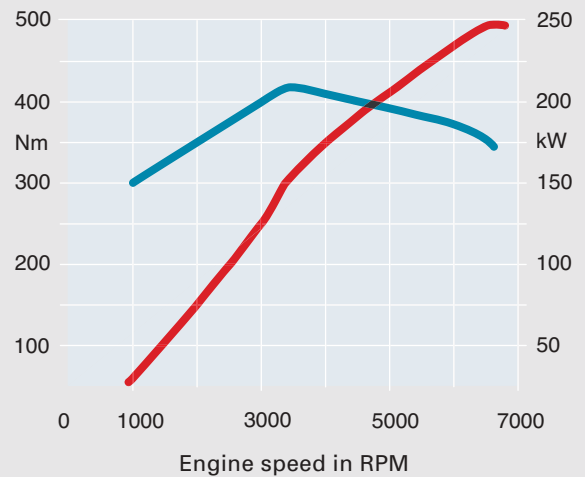

Specifications

Engine code	BMK
Type of engine	8-cylinder vee-engine
Displacement in cm ³	4163
Max. power output in kW (bhp)	220 (300) at 6200 RPM
Max. torque in Nm	380 at 2700 to 4600 RPM
Number of valves per cylinder	5
Bore in mm	84.5
Stroke in mm	92.8
Compression ratio	11 : 1
Firing order	1-5-4-8-6-3-7-2
Fuel grade	Premium unleaded, 98 RON
Exhaust emission control	two primary catalytic converters and two main catalytic converters with lambda control
Engine management	Bosch Motronic ME 7.1.1
Exhaust emission standard	EU IV

4.2-litre V8 engine

Chain drive

Camshaft drive

The 4.2-litre V8 engine has a four-piece chain drive arranged in two planes. The chain drive is located on the transmission side of the engine.

Chain drive A is the basic drive; it propels the camshaft chain drives B and C in the cylinder heads. In each case, the intake camshaft is driven.

Chain drive D drives the ancillary units.

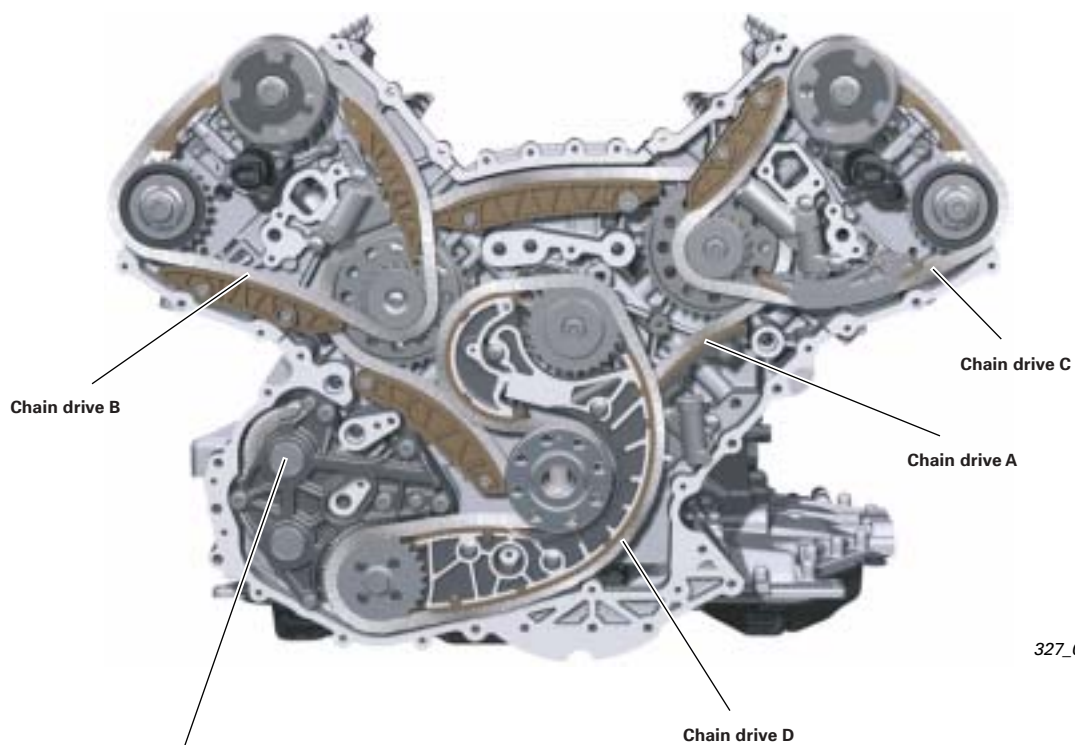

327_069



Ancillary units drive

Chain drive D drives the oil pump, the coolant pump, the power steering pump and the air conditioner compressor pump.
The auxiliary drive has a gear module for adjusting the rotational speed of the coolant pump.
The air conditioner compressor is driven by chain drive D via an additional gear module.

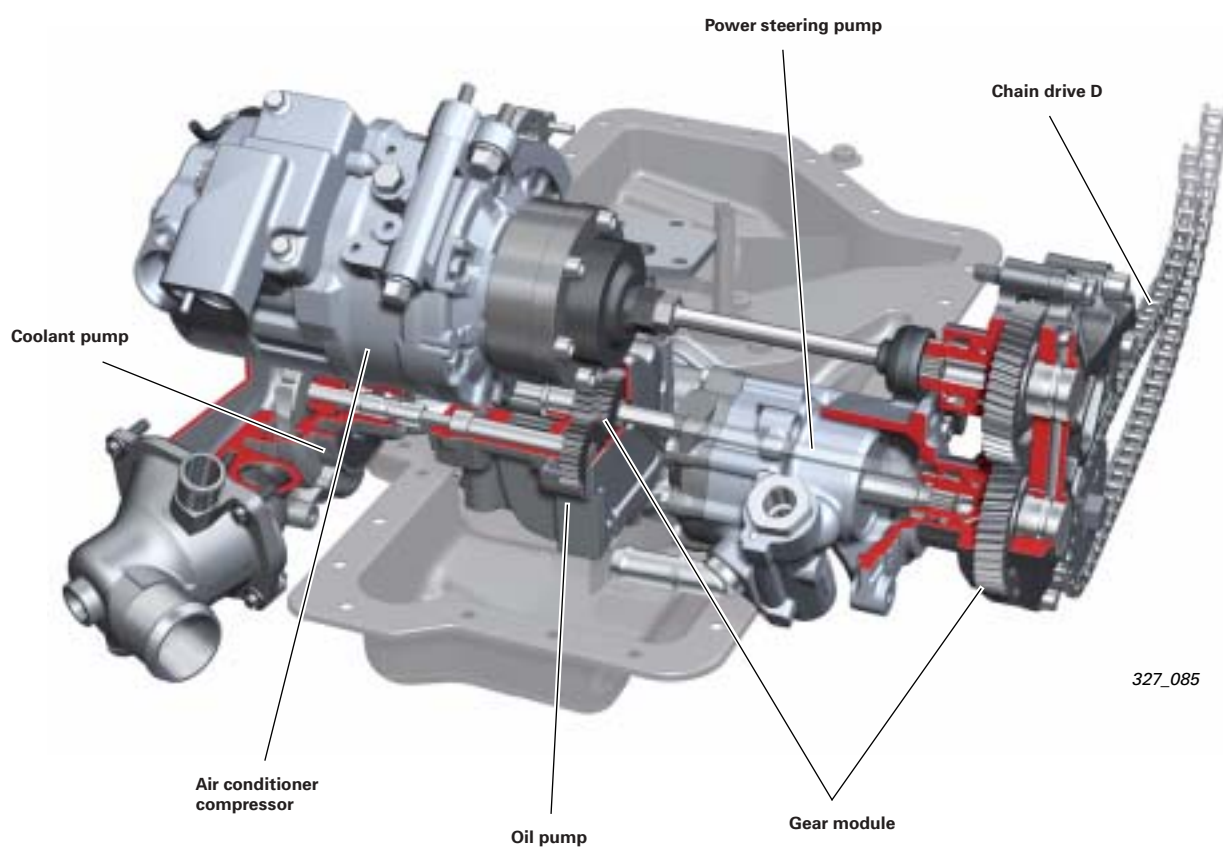

4.2-litre V8 engine

Continuously variable valve timing

Camshaft adjusters which operate according to the vane cell principle are mounted on the intake camshafts.

They continuously adjust the intake camshafts, and hence the valve opening times, within a range of 52°.

Camshaft adjuster, intake camshaft cylinder bank 1

Camshaft adjuster, intake camshaft cylinder bank 2



327_090

Adjustment

The internal rotor is connected to the camshaft and the timing case to the camshaft drive gear.

The engine control unit adjusts the timing of the camshafts over the entire engine RPM range. The camshaft timing data is stored in a map. For adjustment, the inlet camshaft timing adjustment valve is activated by the engine control unit, thus displacing the adjusting piston.

The displacement of the piston opens the passage to the oilway to a degree dependent on the activation signal. This allows the engine oil to flow through the timing advance port into the annular channel. From the annular channel, the engine oil flows through holes in the camshaft into the camshaft adjuster, where it exerts pressure on the vanes of the inner rotor, causing the rotor to counter-rotate relative to the timing case and adjust the camshaft timing.

The timing retard is adjusted according to the same principle, albeit using different oil ports.

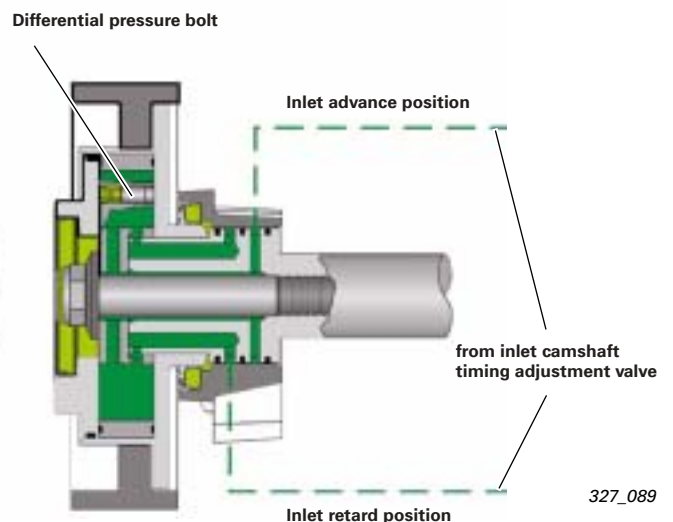
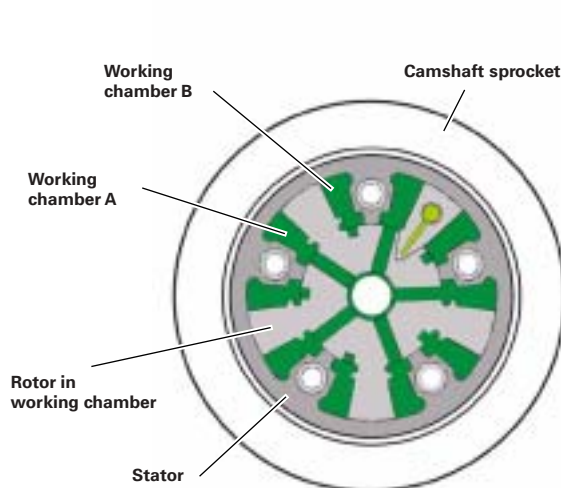

327_089

Intake system

Air filter

The air filter has a compact design with paper round cartridge, front-end intakes and variable wheel-arch intakes. This minimises intake losses even in extreme conditions (spray, snow).

Variable inlet manifold

The variable inlet manifold has two paths. The ram tube is 705 mm long in the 'Torque' position and 322 mm long in the 'Power' position.



'Torque' position

327_094



'Power' position

327_093

Note



The mechanical design of the 4.2-litre V8 engine is otherwise identical to that of the 4.0-litre V8 TDI engine.
Exception: cylinder heads

6.0-litre W12 engine

Description

Technical features

- Camshafts driven by timing chains
- Timing chain on the transmission side
- Continuous intake and exhaust camshaft adjustment
- Dual-circuit cooling system
- Liquid-cooled alternator
- Wet-sump lubrication system
- Catalytic converter with lambda control
- Four air-gap insulated exhaust manifold/catalytic converter modules
- Pneumatically activated exhaust flaps
- Inner exhaust-gas recirculation
- Bosch Motronic engine management system

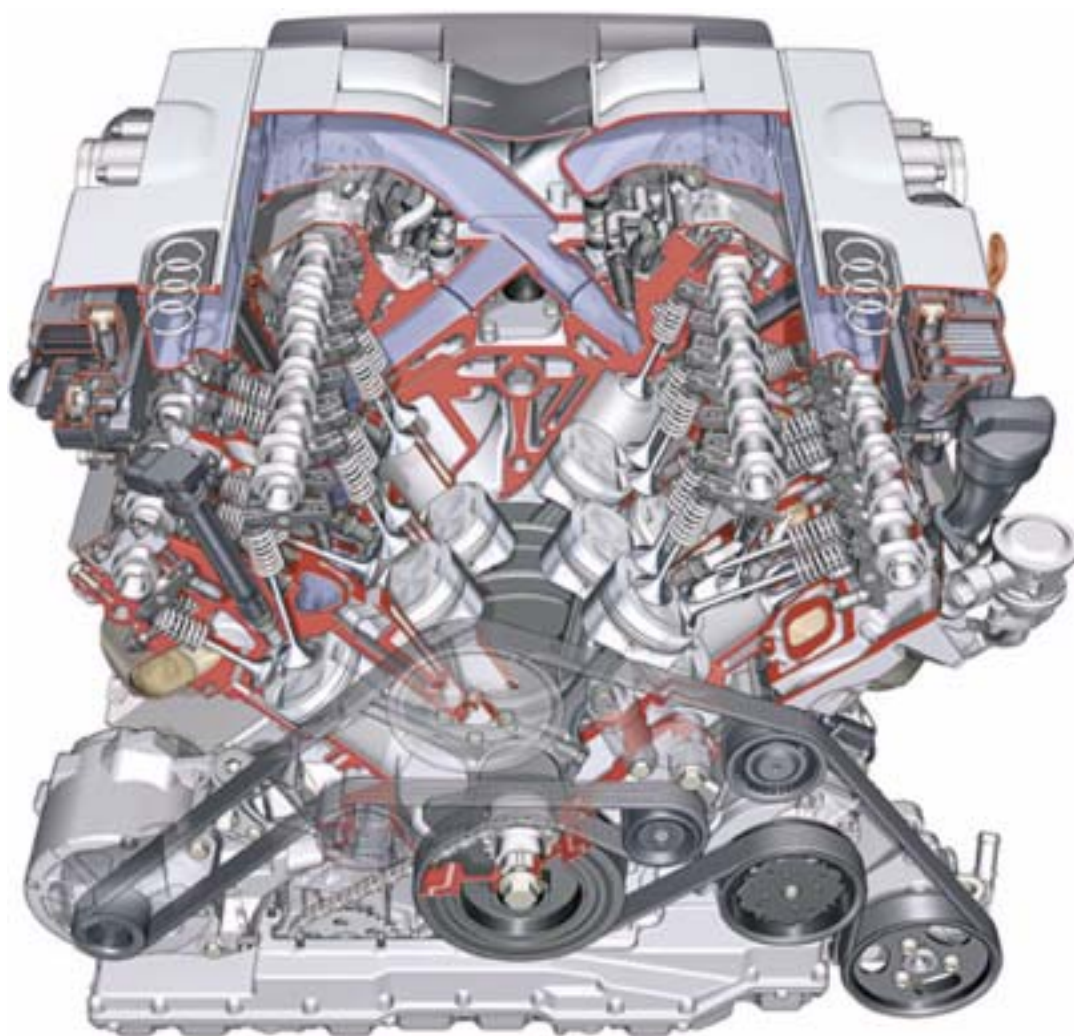

327_006

Reference



For further information, please refer to SSP 267 - The 6.0-litre W12 engine in the Audi A8 - Part 1.

Performance features

Torque and power output

The engine code is located at the front on the cylinder block, below the left-hand cylinder head.

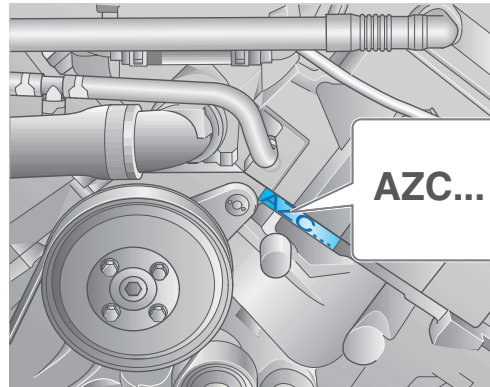

327_077

Torque/power curve

- Max. torque in Nm
- Max. power output in kW

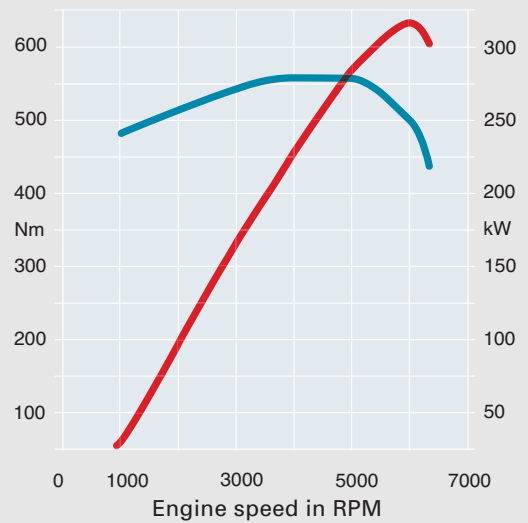

Specifications

Engine code	AZC
Type of engine	12-cylinder W-engine
Displacement in cm ³	5998
Max. power output in kW (bhp)	331 (450) at 6200 RPM
Max. torque in Nm	580 from 4000 to 4700 RPM
Number of valves per cylinder	4
Bore in mm	84
Stroke in mm	90.2
Compression ratio	10.75 : 1
Firing order	1-12-5-8-3-10-6-7-2-11-4-9
Fuel grade	Super Plus unleaded, Euro-Super, 98/95 RON
Exhaust emission control	Closed-loop catalytic converter with 8 lambda probes, air-gap insulated exhaust manifold/ catalytic converter modules
Engine management	Bosch Motronic ME 7.1.1
Exhaust emission standard	EU IV

6.0-litre W12 engine

Chain drive

Camshaft drive

The timing chains are located on the flywheel side of the engine.

The camshaft is driven by a simplex (single-link) chain (primary chain) running from the crankshaft to the intermediate shaft, which connects to a further two simplex chains (secondary chains) running to cylinder banks 1 and 2.

The required reduction ratio from the crankshaft to the camshaft is provided by the different diameters of the sprockets.

The timing chain is tensioned by hydraulic chain tensioners.

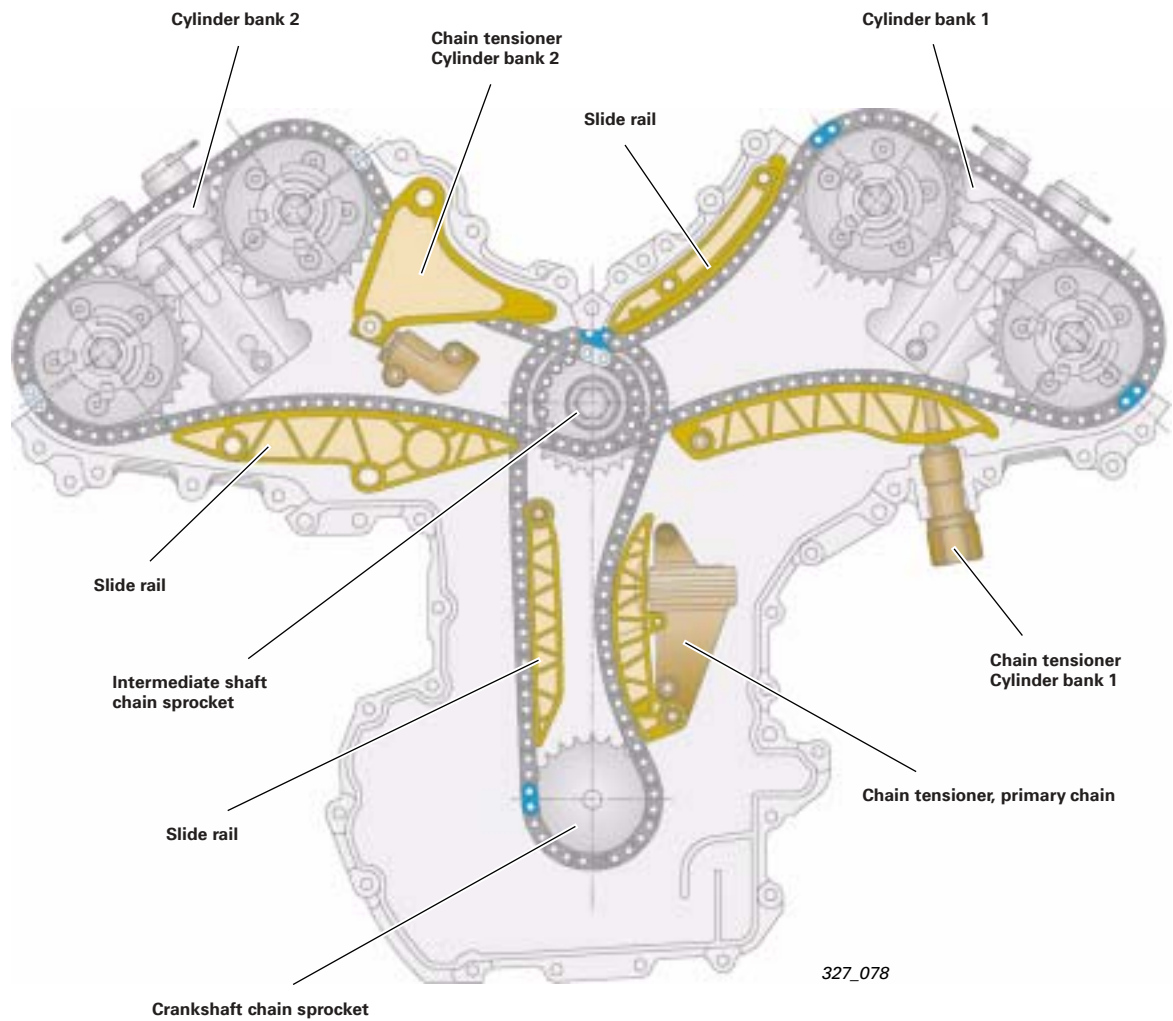

Continuously variable valve timing

The four vane cell adjusters for exhaust and intake camshaft adjustment are supplied with pressurised oil via the engine oil circuit.

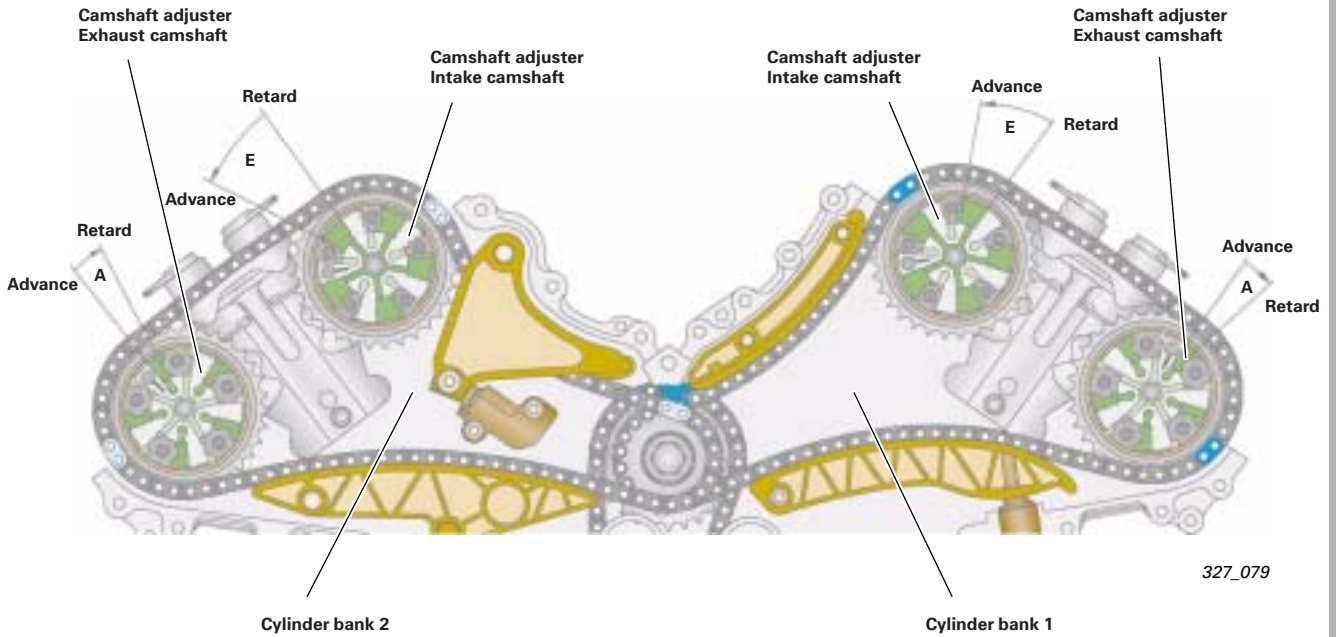

327_079

- A – adjustment range, exhaust 11° (22° crank angle)
- E – adjustment range, intake 26° (52° crank angle)

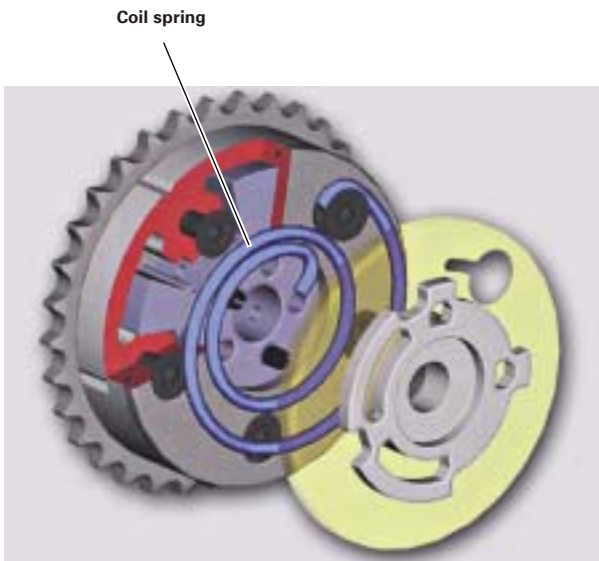

Camshaft adjuster with spring

The oil circuit has been optimised to ensure proper lubrication of the low-friction bearings under all operating conditions. However, an insufficient supply of oil to the camshaft adjusters can occur when the engine is hot-idling. To ensure sufficient oil pressure is available in order to advance the exhaust camshaft timing, an auxiliary coil spring resting on the adjuster housing helps to turn the internal rotor in the "advance" direction.

327_096

6.0-litre W12 engine

Cooling system

Coolant circuit

The coolant pump delivers coolant to the two cylinder banks, where the coolant flow is divided into two partial flows passing through the cylinder banks and cylinder heads.

The coolant then enters the coolant reservoir in the inner vee of the engine, from where it flows to the cooler (primary coolant circuit) or the coolant thermostat and the coolant pump (secondary coolant circuit).

Some of the coolant is tapped from the return line from cylinder bank 1 to cool the alternator and from the return line from cylinder bank 2 to supply the heat exchanger.

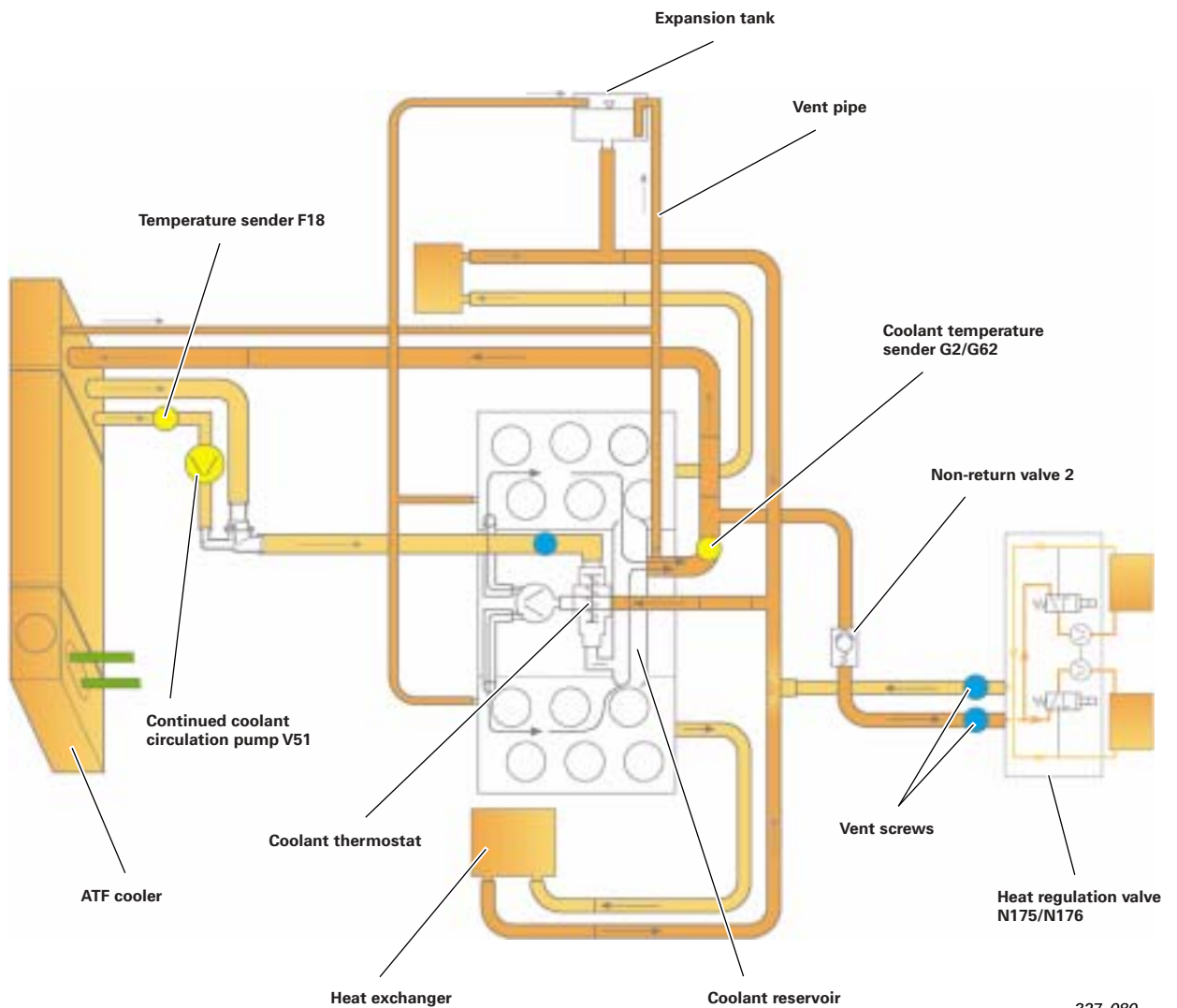

327_080

Oil circuit

Wet-sump lubrication system

The oil circuit in the Audi 6.0-litre W12 engine is designed as a wet-sump lubrication system.

The oil filter and the oil cooler module are attached to the crankcase. The mounting bracket for the water-cooled alternator is located on the oil cooler module.

The main bearings are supplied through an overhead oilway in the vee of the engine.

The camshaft timing chains (secondary chains) have oil injection ports in the chain tensioner rails for lubrication and cooling.

The contact surfaces on the primary chain are lubricated by the oil which flows back from the cylinder heads into the chain housing and through oil injection ports in the secondary chains.

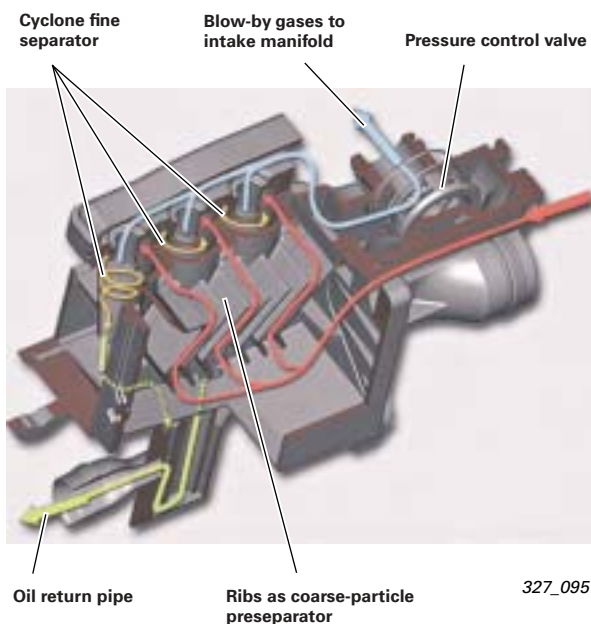
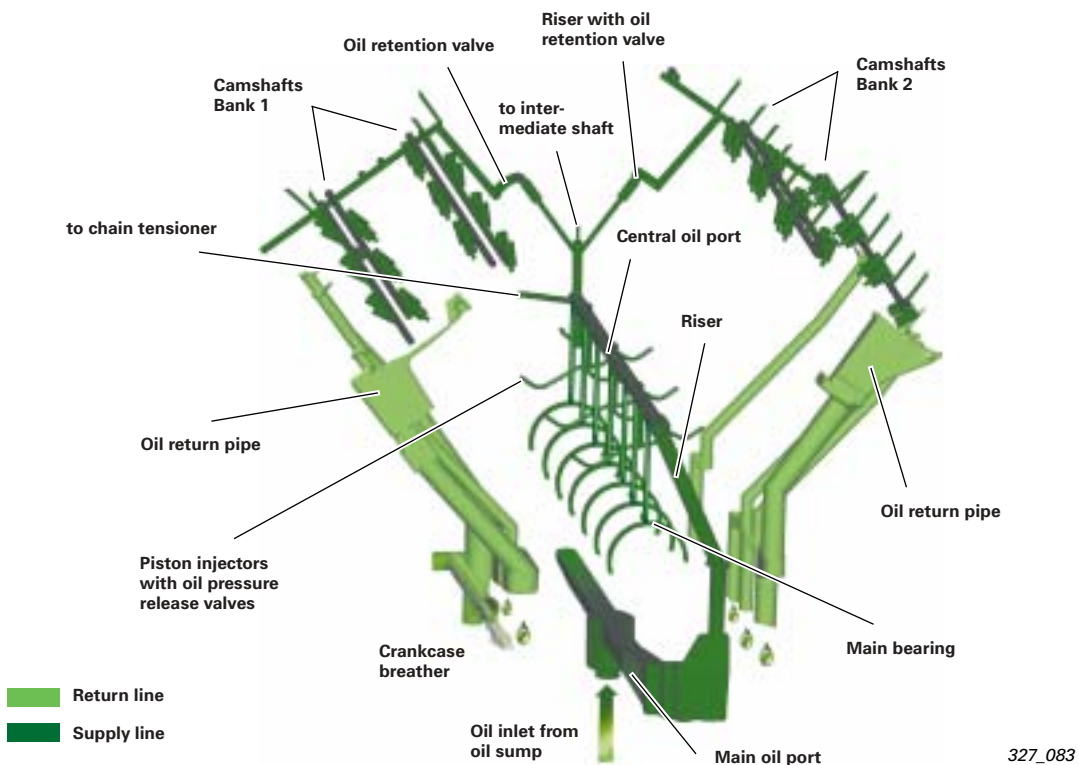

Oil separator

Mounted on the intake manifolds are separator modules which remove oil particles from the blow-by gases. For this purpose, the blow-by gases are channeled to the oil separator through coarse-particle separators integrated in the cylinder heads and lines.

A large proportion of the oil is separated at the inlet to the oil separator by baffle plate separators. Three cyclone fine separators operating in parallel separate the existing ultra-fine oil droplets and channel the blow-by gases through a pressure control valve into the cylinder bank intake manifolds.

The separated oil collects in the bottom part of the separator and returns directly to the cylinder heads.

6.0-litre W12 engine

Exhaust system

Exhaust manifold

The four 3-in-1 manifolds, the two headpipes and the four close-coupled catalytic converters have been combined to create four manifold/catalytic converter modules.

Dispensing with a flanged connection between the headpipe and the manifold offers the following advantages:

- enhanced inflow to the close-coupled catalytic converters
- no flange-related heat loss
- better pipe layout
- reduced weight

Manifold/catalytic converter module 1

Manifold/catalytic converter module 2



327_098

Inner exhaust gas recirculation

Nitrogen oxides are reduced by the internal exhaust gas recirculation system.

The proportion of exhaust gas recirculated is defined by the intake and exhaust camshaft adjustments.

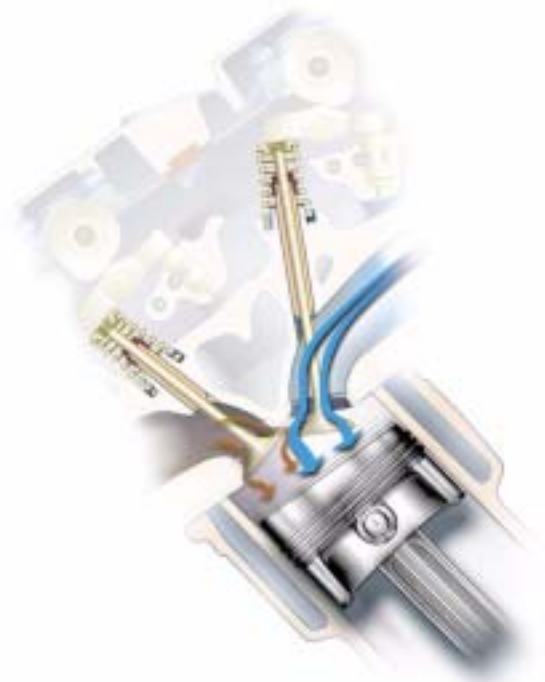

327_082

Information on engine selection

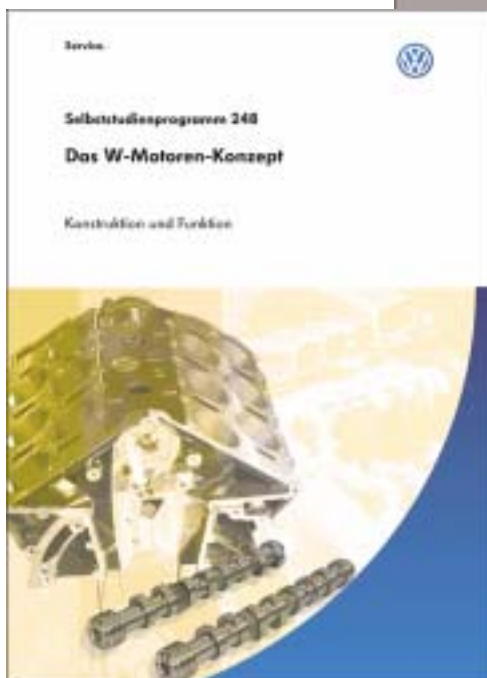
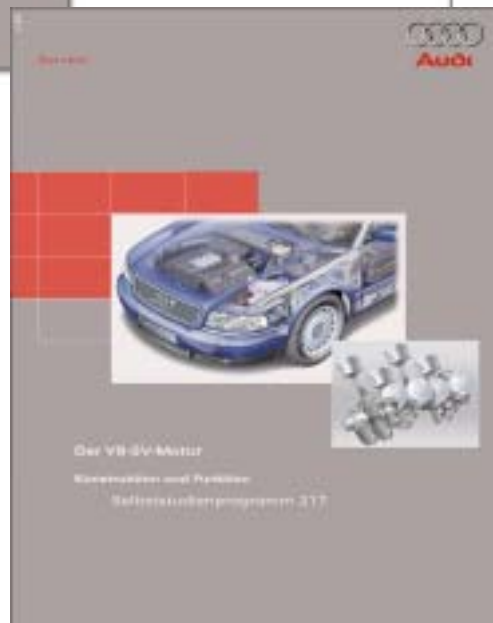
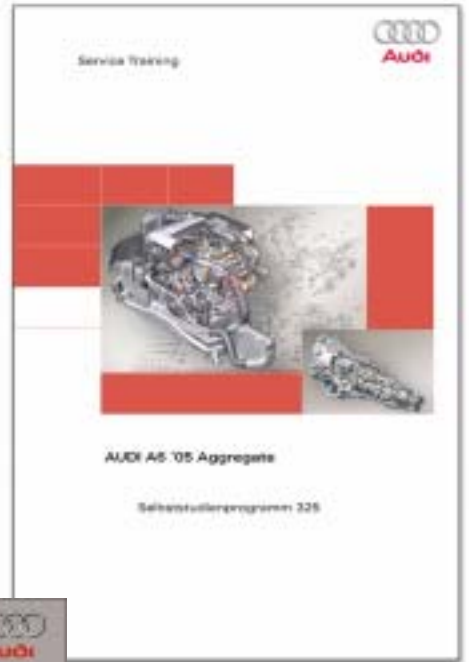

All rights reserved.
Technical specifications
subject to change without
notice.

Copyright
AUDI AG
I/VK-35
Service.training@audi.de
Fax +49-841/89-36367

AUDI AG
D-85045 Ingolstadt
Technical status: 08/04

Printed in Germany
A04.5S00.10.20