

Cam shaft Timing Chain, Removing from Cam shaft, Chain Tensioner

Special tools and workshop equipment required

1 Counter Holder -T10172- with Pin -T10172/2-

1 Adapter -T40058-

1 Locking Pin -T40069-

1 Cam shaft Locator -T40070- (qty. 2)

1 Locking Pin -T40071- (qty. 2)

1 Multi-Point Socket -T10035-

Removing



Note

The cam shaft timing chains remain on the engine in the following description. If the timing chains for cam shafts are to be completely removed, the lower timing chain cover must also be removed. Refer to [→ Chapter „Lower Timing Chain Cover“](#).

- Remove the cylinder head cover. Refer to: Left [→ Chapter „Left Cylinder Head Cover“](#), right [→ Chapter „Right Cylinder Head Cover“](#).
- Remove left and right timing chain covers. Refer to [→ Chapter „Left and Right Timing Chain Covers“](#).

- Insert guide pin of Adapter -T40058- so that large diameter -arrow 1- points to engine. Small diameter -arrow 2- points to adapter.

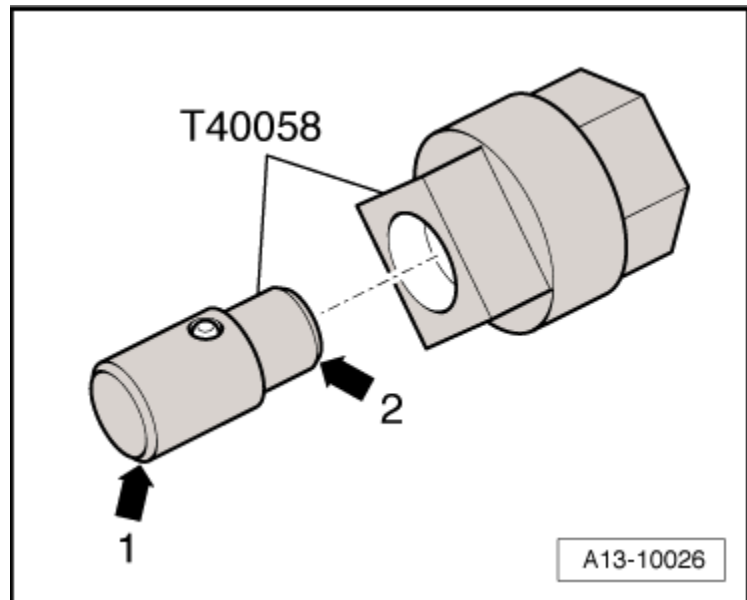

- Using Socket -T40058-, rotate crankshaft in direction of engine rotation -arrow - to TDC.

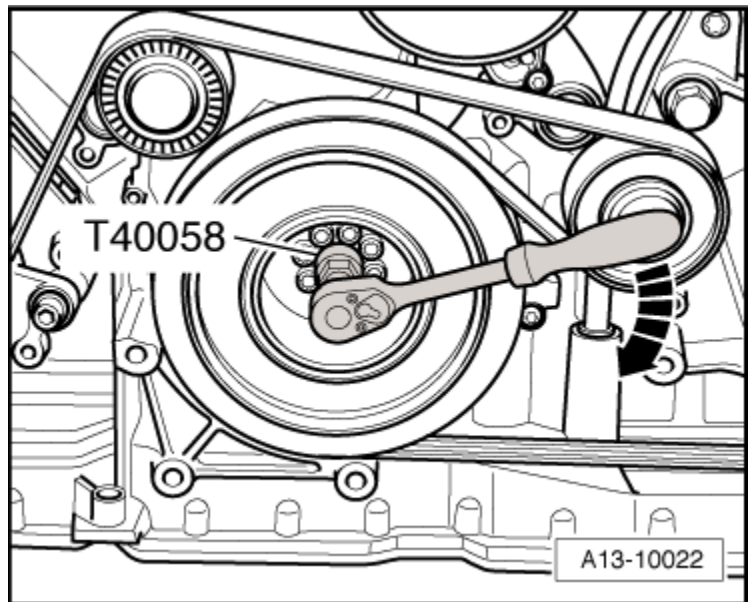

A13-10022

1 The threaded holes -arrow s- in the cam shafts must face upward.

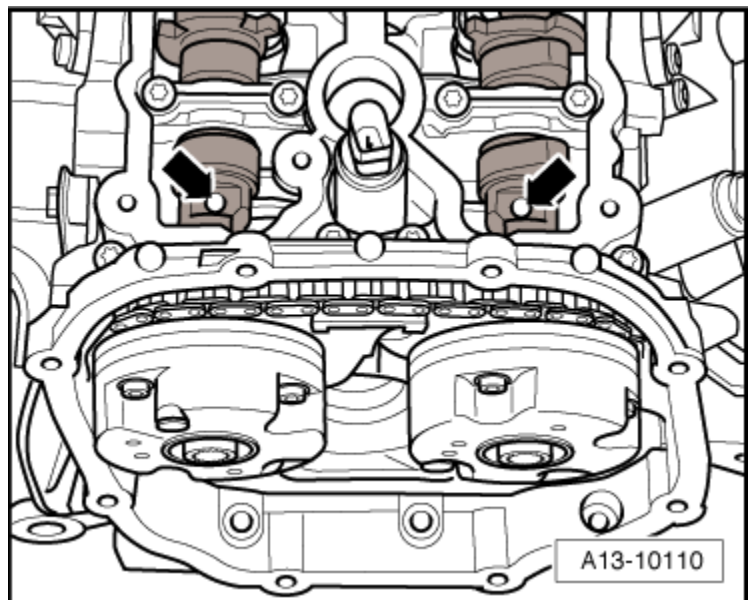

A13-10110

Mount the Cam shaft Locating Tool - T40070 - on both cylinder heads and tighten the bolts -arrow s- to 20 Nm .

The Cam shaft Locating Tool -T40070- is correctly positioned when the holes for the cylinder head bolts remain free.

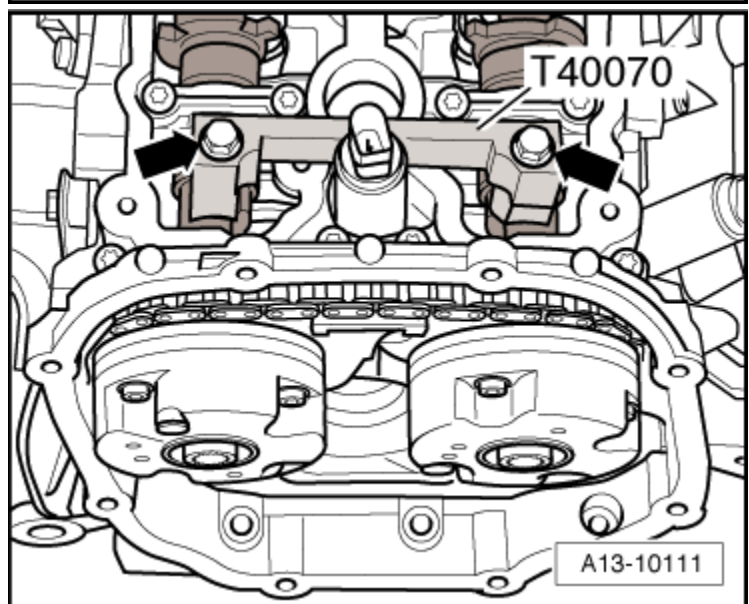

A13-10111

- Remove sealing plug -arrow- from cylinder block.

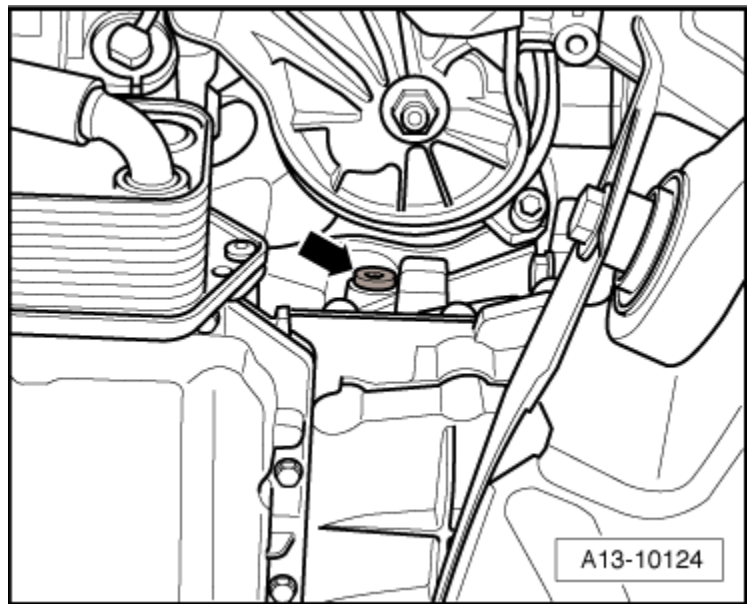

- Install the Crankshaft Holder -T40069- in the hole -1- to 10 Nm . If necessary rotate the crankshaft back and forth slightly to completely center the holder.

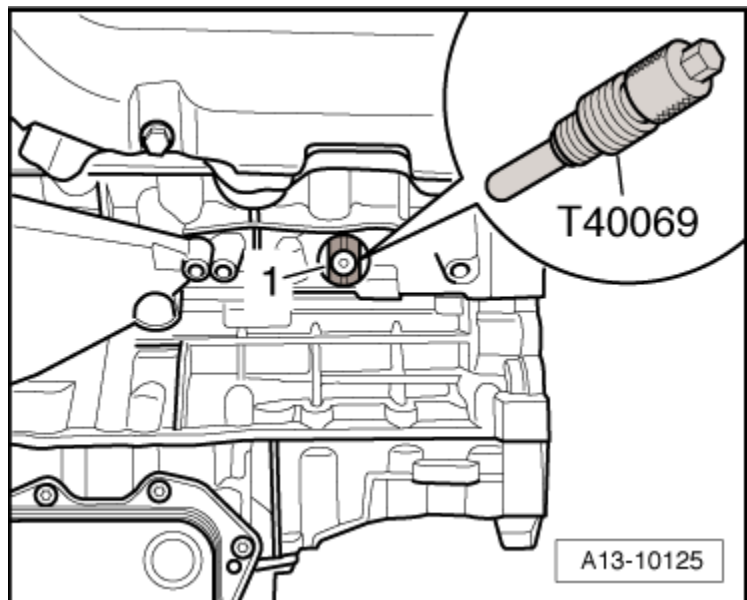

- Mark running direction of left cam shaft timing chain with paint.
- Remove bolts -1- and -2- for cam shaft adjuster using Multipoint Socket -T10035-.
- Remove both cam shaft adjusters.

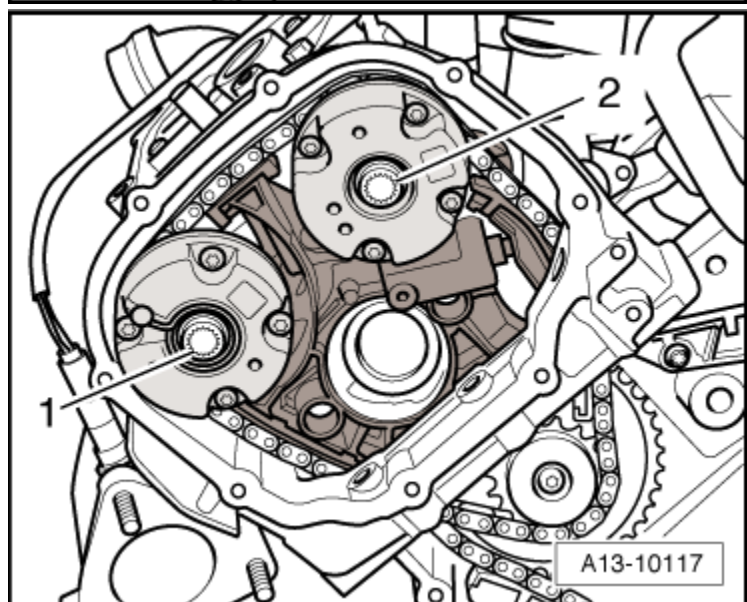

- Remove bolts -1- and -2- and remove chain tensioner.

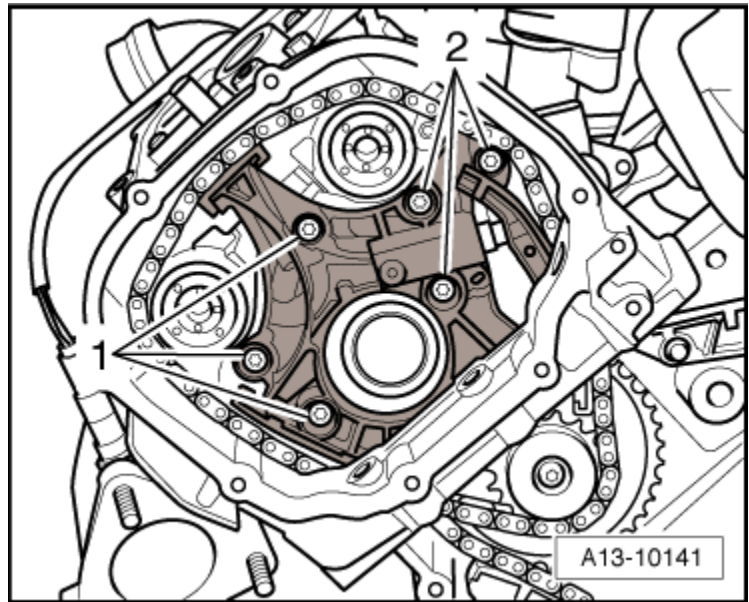

- Mark running direction of right cam shaft timing chain with paint.
- Remove bolts -1- and -2- for cam shaft adjuster using Multipoint Socket -T10035-.
- Remove both cam shaft adjusters.

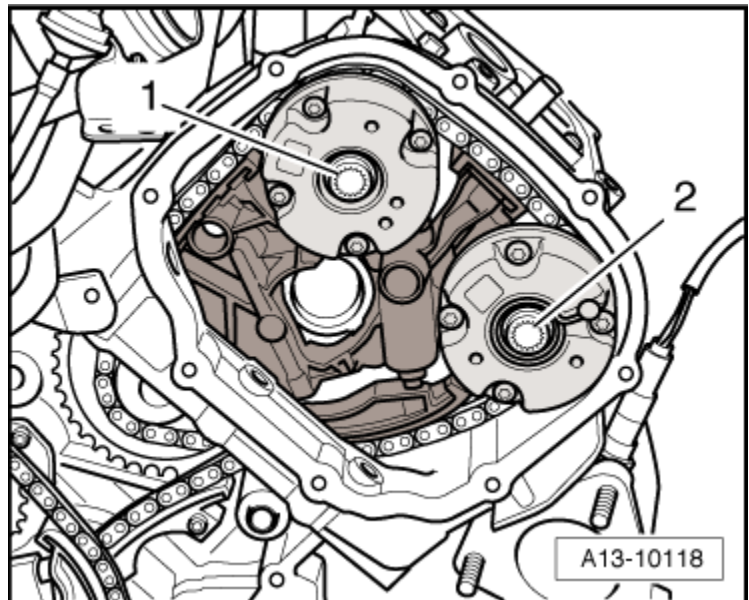

- Remove bolts -1- and -2- and remove chain tensioner.

Installing



Note

Always replace bolts that are tightened to torque as well as O-rings and gaskets.

When turning cam shaft, crankshaft must not be at TDC for any cylinder. Valves and/or pistons may be damaged.

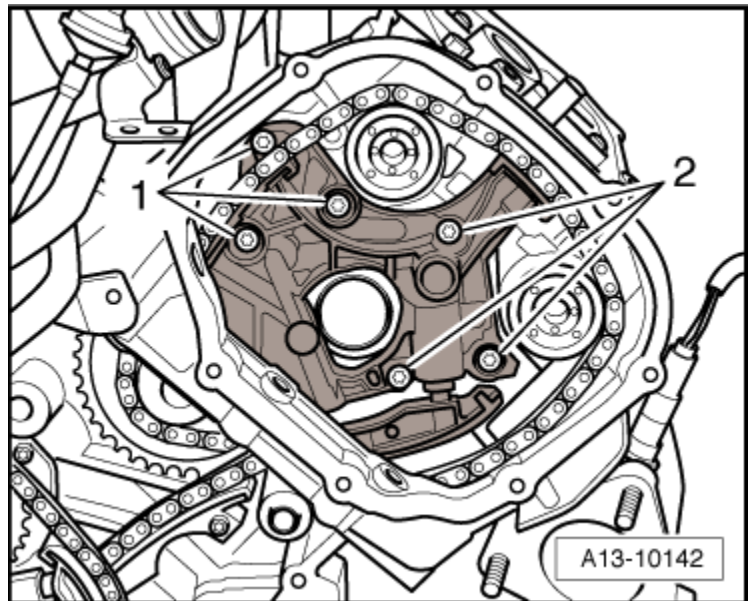

Drive chain for timing mechanism

1 installed. Refer to [→ Chapter „Timing Mechanism Drive Chain“](#).

1 Secure crankshaft in TDC position using Crankshaft Holder -T40069-.

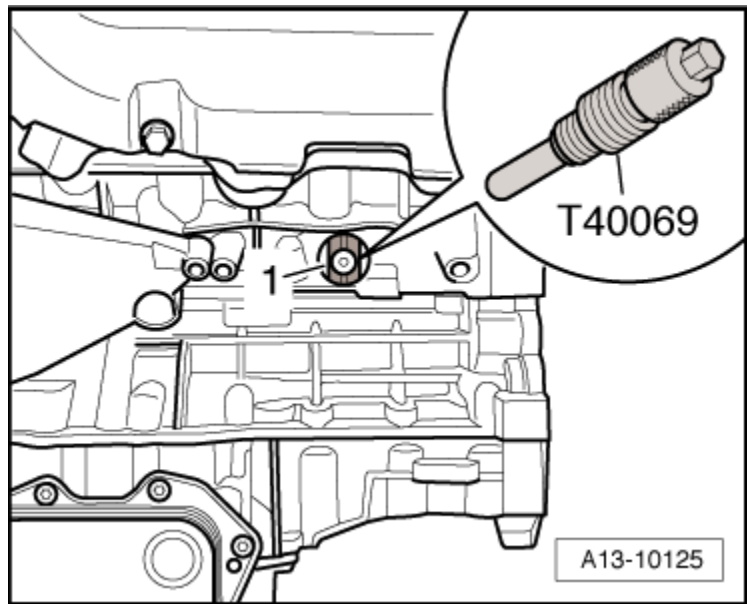

Cam shaft Locating Tool -T40070- mounted on both cylinder heads and tightened to 20 Nm .

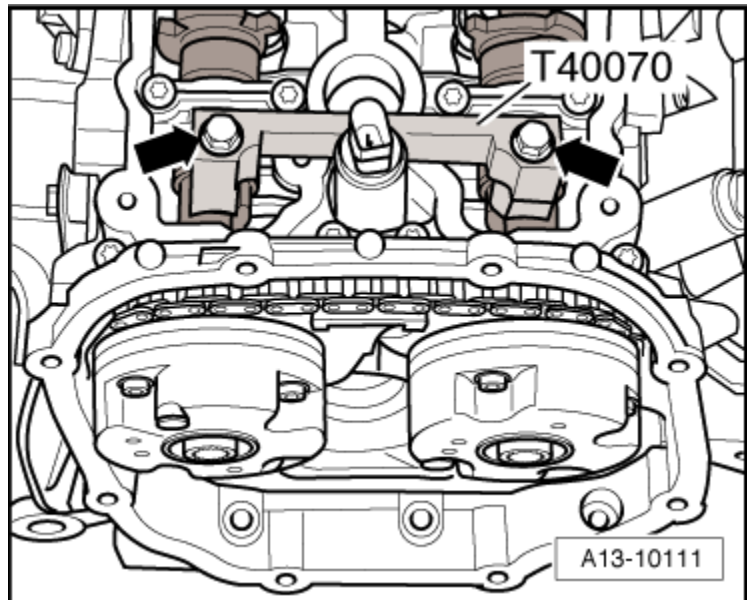

1 Fully relieve tension of guide rail for left and right cam shaft timing chain tensioner - arrow -.

1 The piston of the tensioning element must be driven out completely, thereby releasing the retainer - for this the chain tensioner must be removed.



Note

If the tensioning element is to be removed from the chain tensioner, observe the installed position: Hole in housing floor faces toward chain tensioner, piston faces toward tensioning rail.

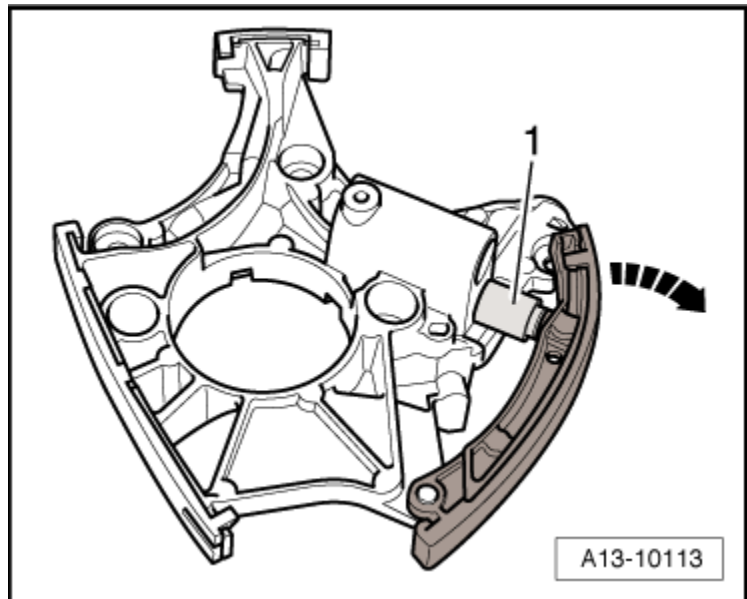

- Press the guide rail of the left and right cam shaft timing chain inward -arrow- up to the stop and secure the chain tensioner with the Locking Pin -T40071-.

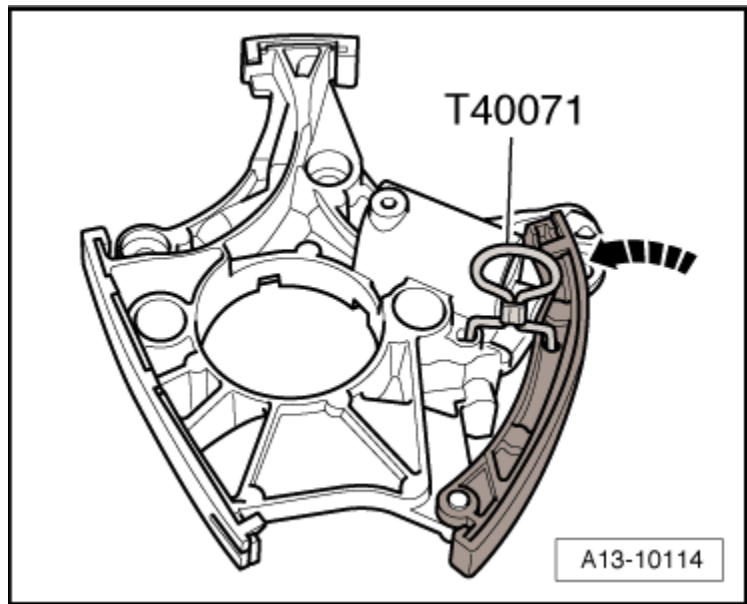

- Clean oil strainer -3- in both chain tensioners if necessary.
- Place a new gasket -2- onto the rear of the chain tensioner -1-.

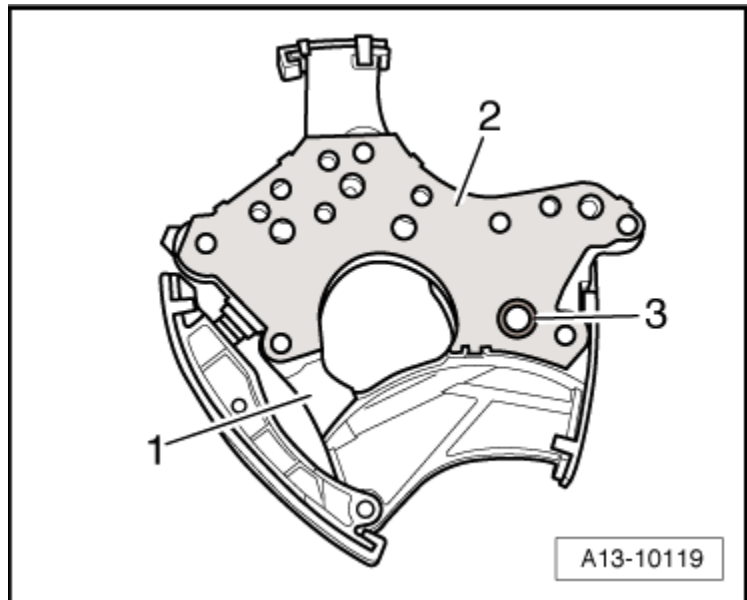

- Set the chain tensioner in place on the left cylinder head and install the cam shaft timing chain, as shown in the illustration.
- Tighten bolts -1- and -2-.

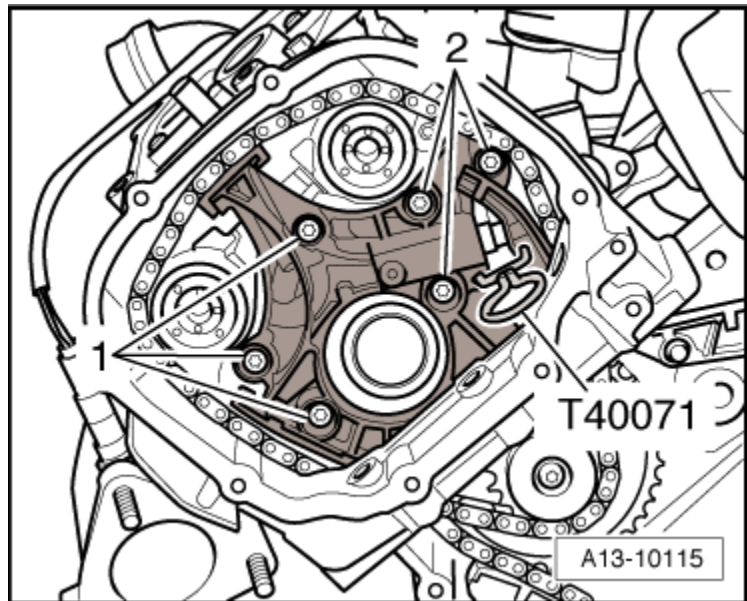

- Replace cam shaft bolts.
- Place cam shaft timing chain onto drive sprocket and onto cam shaft adjusters and loosely thread in the bolts -1- and -2-.
- Both cam shaft adjusters must be able to still be rotated on cam shaft and must not tip.
- Remove Locking Pin -T40071-.

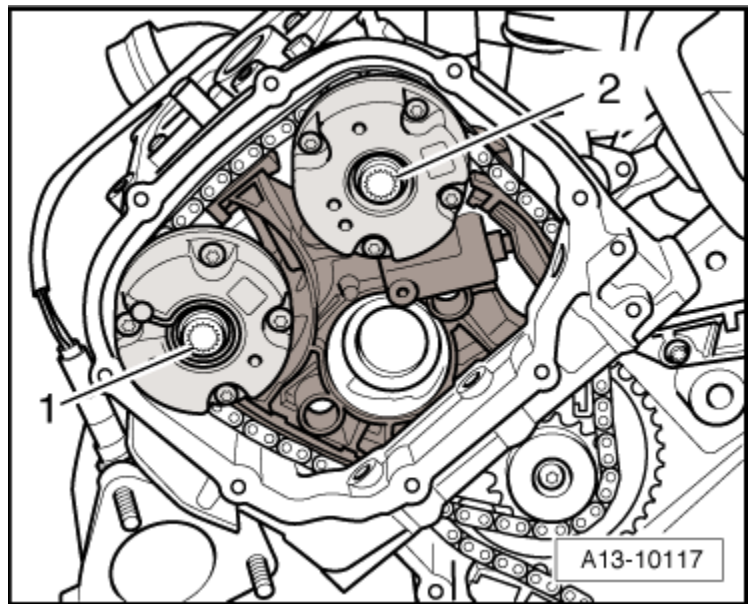

- Set the chain tensioner in place on the right cylinder head and install the cam shaft timing chain, as shown in the illustration.
- Tighten bolts -1- and -2-.

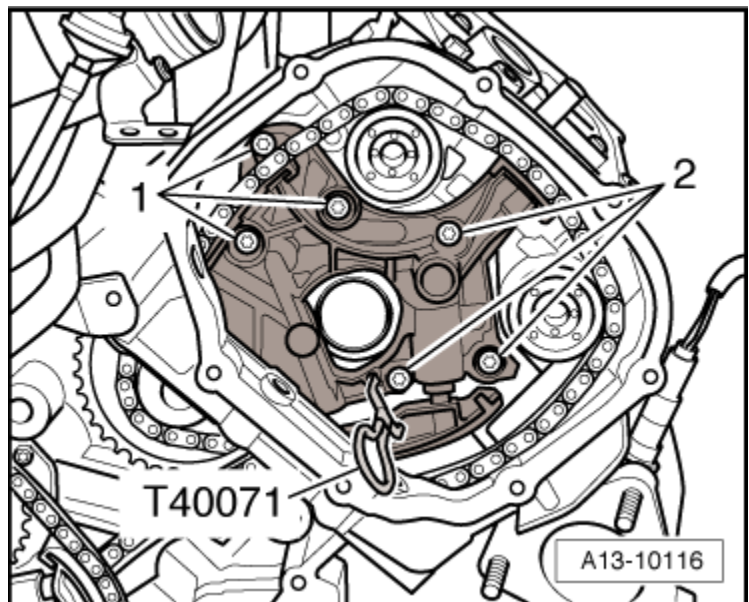

- Replace cam shaft bolts.
- Place cam shaft timing chain onto drive sprocket and onto cam shaft adjusters and loosely thread in the bolts -1- and -2-.
- Both cam shaft adjusters must be able to still be rotated on cam shaft and must not tip.
- Remove Locking Pin -T40071-.

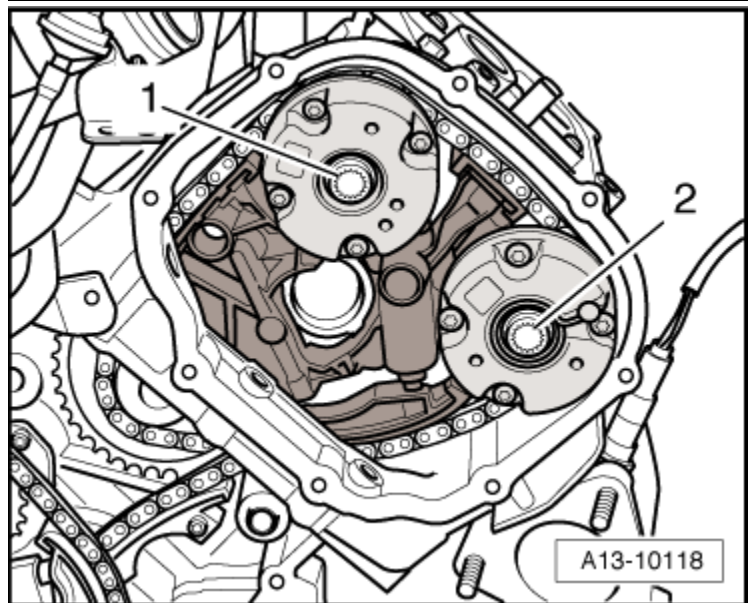

- Set the Counter-Holder -T10172- with Pin -T10172/2- in place on the cam shaft adjuster of the left intake cam shaft.
- Hold the cam shaft timing chain pretensioned by pressing on counter-holder in direction of arrow -.
- Simultaneously, pre-torque the cam shaft bolt using the Multipoint Socket -T10035- and torque wrench.
- 1 Tightening Specifications: 40 Nm .
- Continue holding the pretension on the intake cam shaft and pre-torque the bolt -1- on the exhaust cam shaft.
- 1 Tightening Specifications: 40 Nm .

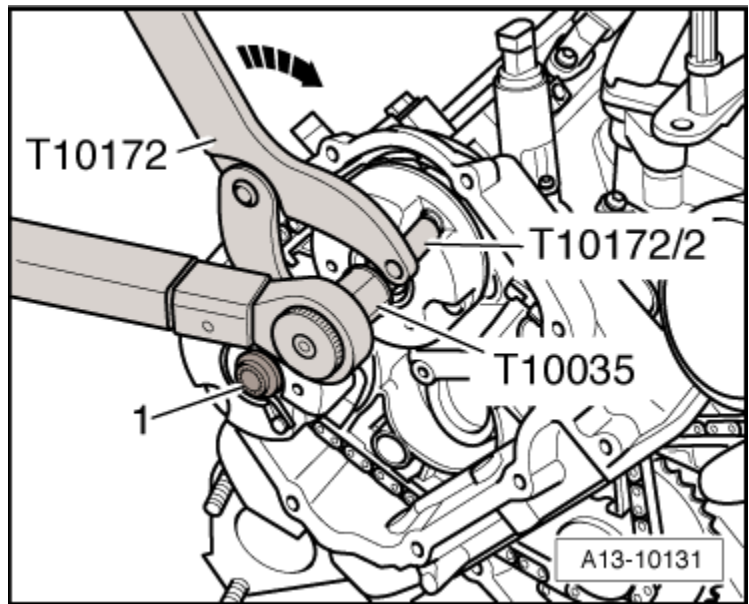

- Tighten cam shaft bolts -1- and -2- on left cylinder head to final tightening specification.
- 1 Tightening Specifications 80 Nm plus an additional 90° turn.

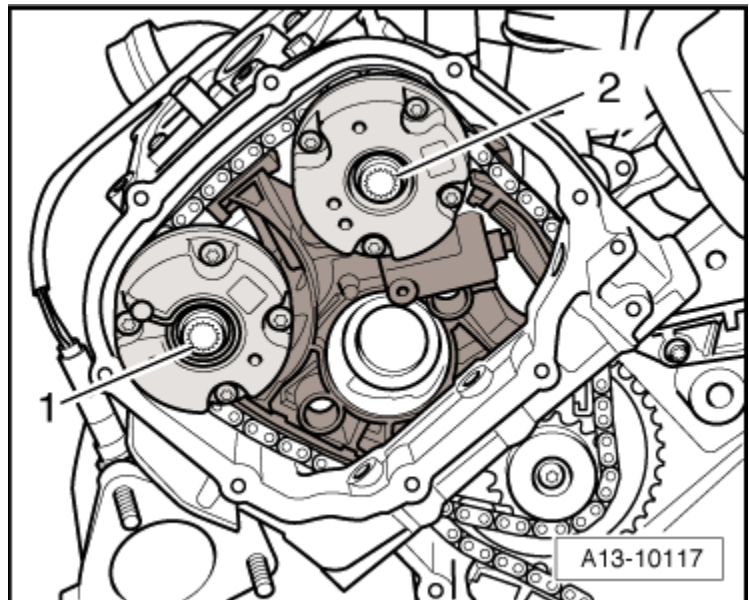

- Set the Counter-Holder -T10172- with Pin -T10172/2- in place on the cam shaft adjuster of the right exhaust cam shaft.
- Hold the cam shaft timing chain pretensioned by pressing on counter-holder in direction of arrow -.
- Simultaneously, pre-torque the cam shaft bolt using the Multipoint Socket -T10035- and torque wrench.
- 1 Tightening Specifications: 40 Nm .
- Continue holding the pretension on the exhaust cam shaft and pre-torque the bolt -1- on the intake cam shaft.
- 1 Tightening Specifications: 40 Nm .

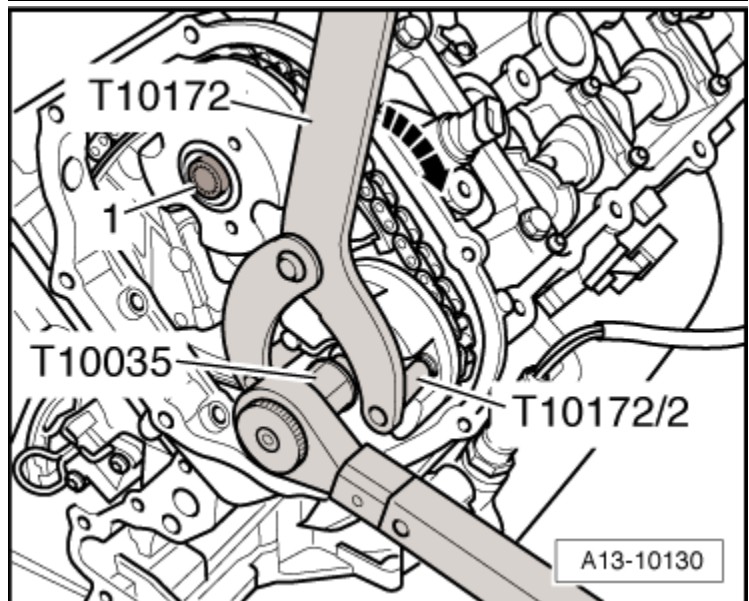

Tighten cam shaft bolts -1- and -2- on right cylinder head to final tightening specification.

1 Tightening Specifications: 80 Nm plus an additional 90° turn.

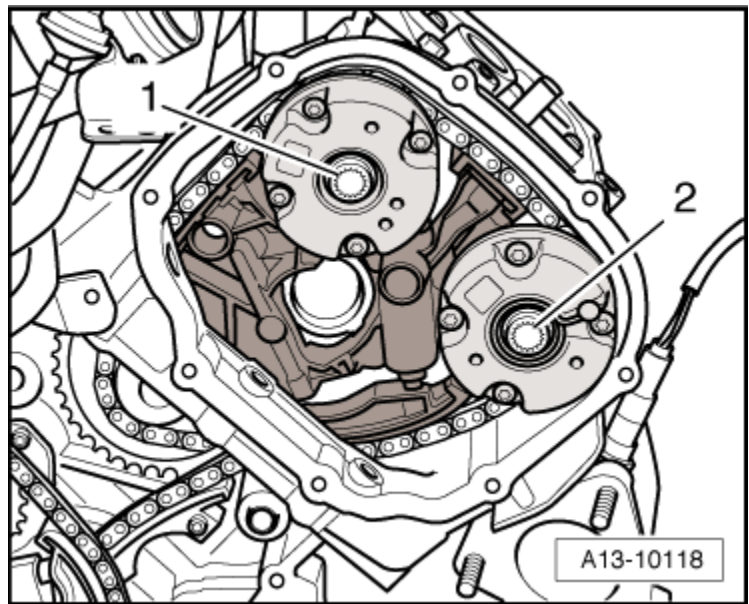

Remove Cam shaft Locators -T40070- on both cylinder heads.

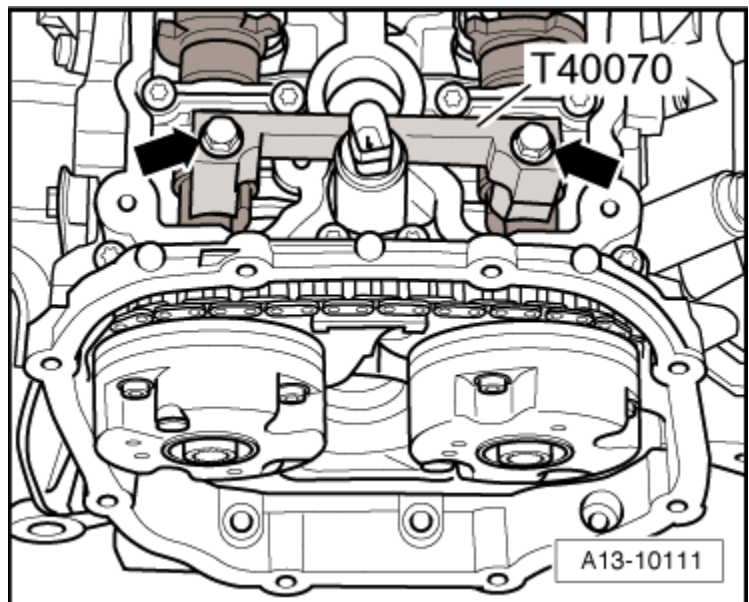

Remove Crankshaft Holder -T40069-.

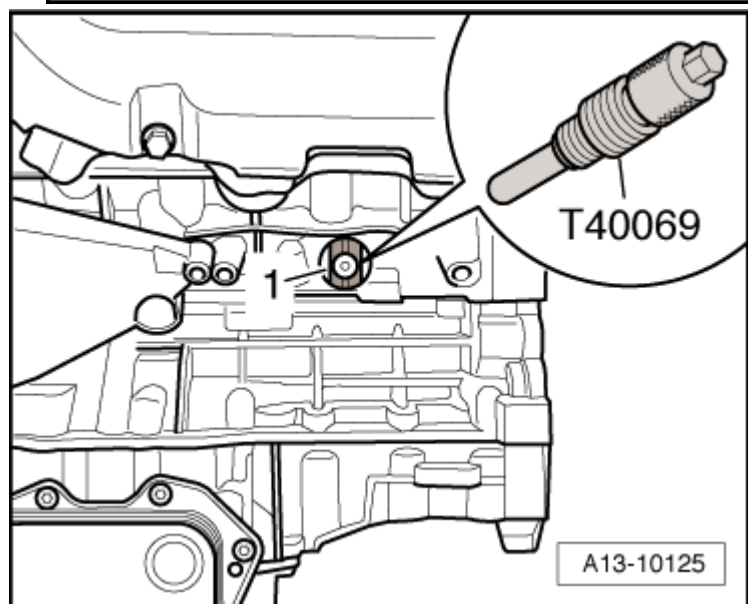

Using Key -T40058- turn crankshaft two complete rotations in direction of engine rotation -arrow- until crankshaft stands at TDC again.



Note

If rotated unintentionally beyond TDC, turn back crankshaft again approximately 30° and set to TDC again.

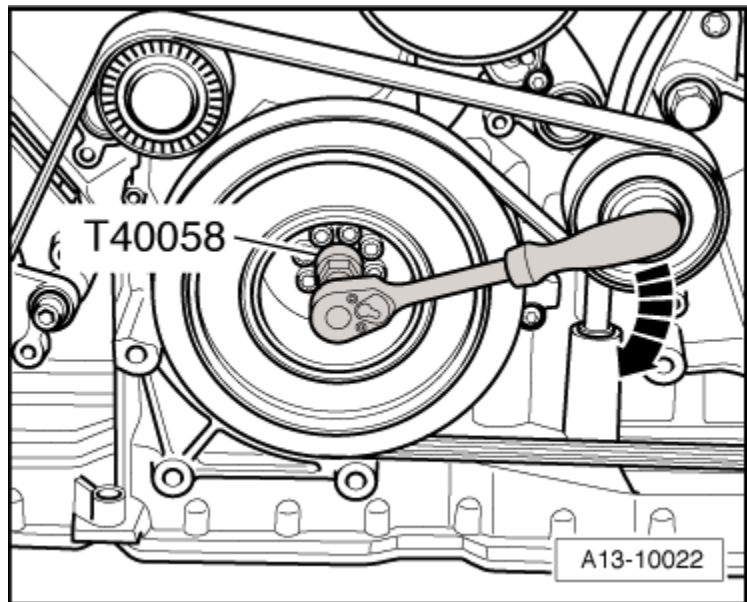

1 The threaded holes -arrow s- in the cam shafts must face up ward.

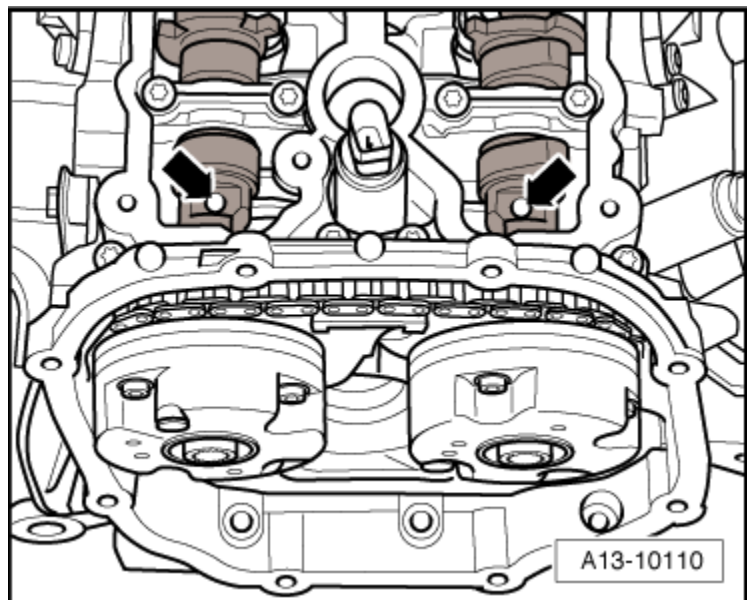

Mount the Cam shaft Locating Tools - T40070- to both cylinder heads and tighten the bolts -arrow s- to 20 Nm .

The Cam shaft Locating Tool -T40070- is correctly positioned when the holes for the cylinder head bolts remain free.

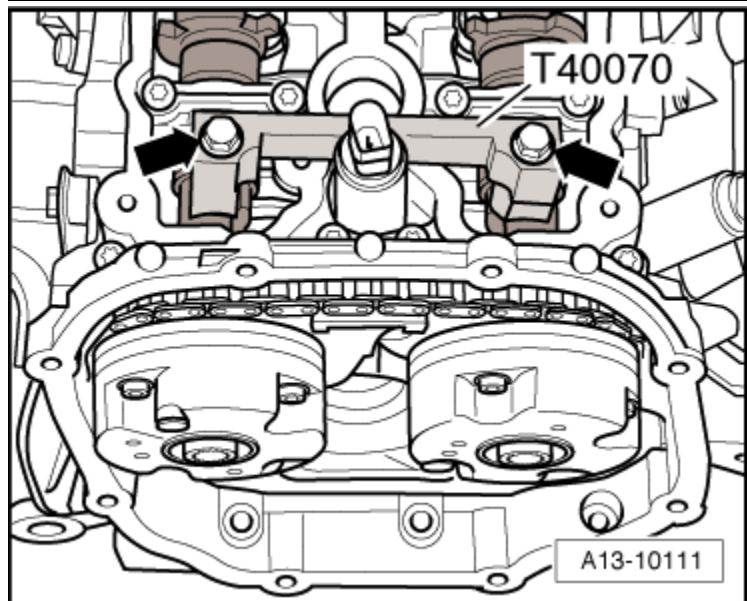

- Screw the Crankshaft Holder -T40069- directly into the hole.

The Crankshaft Holder -T40069- must engage in the locating hole of the crankshaft -1-, otherwise repeat the adjustment.

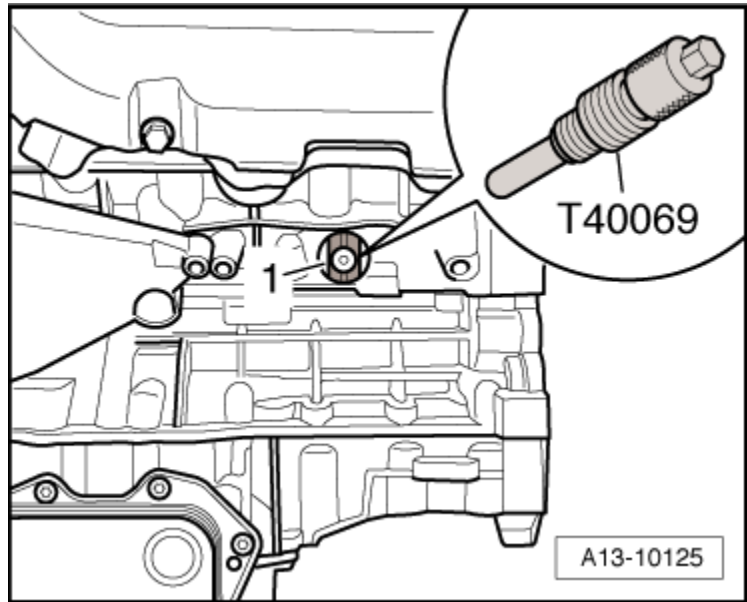

- Remove cam shaft locating tools on both cylinder heads.
- Remove crankshaft holder.
- Screw sealing plug of TDC marking with new seal into cylinder block.

Further installation is in reverse order of removal, note the following:

- Install left and right timing chain covers. Refer to → [Chapter „Left and Right Timing Chain Covers“](#).
- Install cylinder head cover. Refer to: Left → [Chapter „Left Cylinder Head Cover“](#), right → [Chapter „Right Cylinder Head Cover“](#).

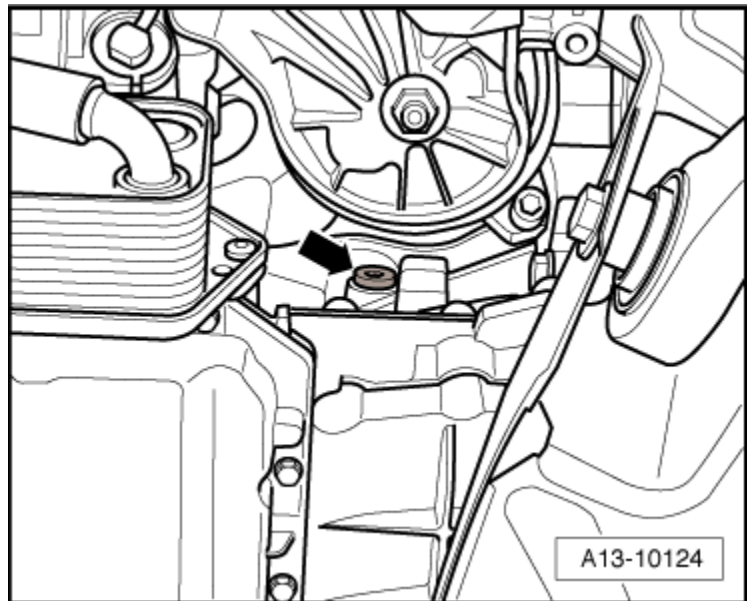

Tightening Specifications

Component	Nm
Chain tensioner to cylinder head	9
Cam shaft bolts	80 +90° ¹⁾
Sealing plug in cylinder block	14 ²⁾
1 ¹⁾ Replace bolts. 1 ²⁾ Install with new gasket.	