

- ◆ Spanner Wrench -3212-
- ◆ Hose Clamp Pliers -VAS 6362-

Removing

- Pull front engine cover off -arrows-.

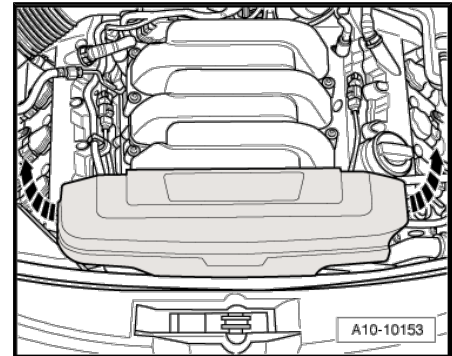

- Remove bolts -arrows-.
- Remove the air duct -1- and -2-.



Note

*Before removing the ribbed belt, mark the turning direction on it with chalk or a felt tip pen. A reversed turning direction can cause damage to the belt under operating conditions.*

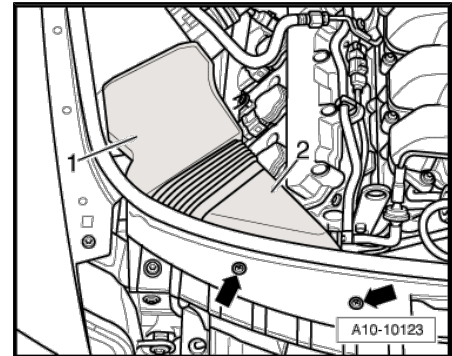

- Pivot tensioning device in direction of -arrow- to relieve tension on ribbed belt.
- Remove ribbed belt from the coolant pump.
- Release tensioner unit

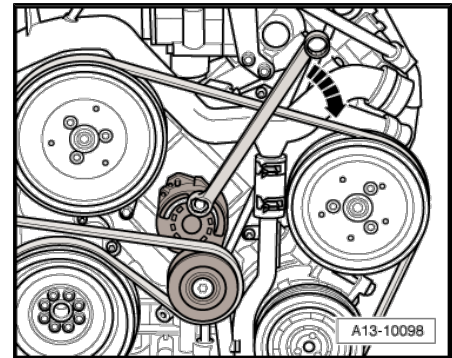

- Remove ribbed belt pulley from the coolant pump.
- When loosening bolts use Spanner Wrench -3212- to counterhold.

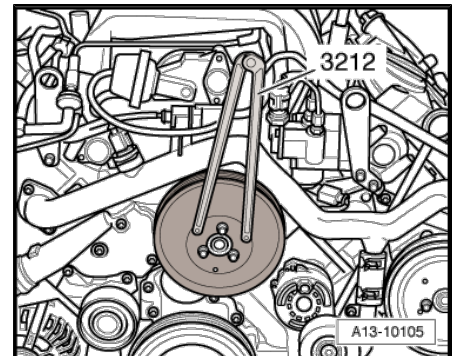

Protected by copyright. Copying for private or commercial purposes, in part or in whole, is not permitted unless authorised by AUDI AG. AUDI AG does not guarantee or accept any liability with respect to the correctness of information in this document. Copyright by AUDI AG.



- Separate the electrical connector -3-.
- Disconnect coolant hoses -arrows- from front coolant pipe.
- Remove bolts -1-, -2-, -4- and -5- and remove front coolant pipe.

#### Installing

Installation is in reverse order of removal, note the following:

#### Note

- ◆ *Replace seals and O-rings.*
- ◆ *Secure all hose connections with hose clamps appropriate for the model. Refer to ⇒ Electronic Parts Catalog "ETKA".*
- Clean and/or smooth O-ring sealing surface before installing.
- Coat a new O-ring with coolant and slide it onto the coolant pipe.
- Install ribbed belt. Refer to ⇒ **"4.3 Ribbed Belt", page 97** .
- Fill with coolant ⇒ **page 218** .

#### Tightening Specifications

Component	Nm
Front coolant pipe to engine	9
Ribbed belt pulley to coolant pump	20

## 5.5 Left Coolant Pipes

Special tools and workshop equipment required

- ◆ Drip Tray for Workshop Crane -VAS 6208-
- ◆ Hose Clamp Pliers -VAS 6362-

#### Removing

- Pull front engine cover off -arrows-.

#### Note

*Before removing the ribbed belt, mark the turning direction on it with chalk or a felt tip pen. A reversed turning direction can cause damage to the belt under operating conditions.*

