

Eine gu-run bed and i  
Operat lead bt  
unbeme rkt.

Vehicle functions and infotainment at the top level. Sovereign controlled easily. Thanks to an operator that is so intuitive that you hardly noticed her. So you can indulge fully the fun with the new Audi A7 Sportback.

The fuel consumption and CO<sub>2</sub> emissions and efficiency categories, see page 56. In the illustrated and described equipment is partially about options at extra cost. Detailed information on standard and optional equipment available at [www.audi.de](http://www.audi.de) or your Audi partner.

01 Audi virtual cockpit (optional)  
12.3-inch color display incl. Display of the navigation map



Highlights

28

02 Control buttons glass look black with proximity sensor and haptic feedback including extended aluminum look (optional)



03 MMI navigation plus with MMI touch response (optional) for fast, intuitive operation



29

# Komf place ha tei nen ne u s Ho ri horizon.

To go feel comfortable - a question of atmosphere. The new Audi A7 Sportback, you can determine this yourself. For example, the optional panoramic glass roof that combines a bright and friendly atmosphere with a greater sense of space. High indoor air quality promises optionally the Air Quality package consisting of ionizer and flavoring. For individual air conditioning in every seat, the 4-zone deluxe automatic air conditioning ensures if desired. Thanks to personalization, occupant detection and sensor-based intelligent control quickly and efficiently.

The fuel consumption and CO<sub>2</sub> emissions and efficiency categories, see page 56. In the illustrated and described equipment is partially about options at extra cost. Detailed information on standard and optional equipment available at [www.audi.de](http://www.audi.de) or your Audi partner.



# Vorwärts ist the best Himmel ist direct.

The performance of a sports car combined with the refinement of a luxury sedan. As comfortable forward thrust can be. Thanks to the optional suspension including damping control with electronically controlled adaptation to different driving situations or adaptive air suspension with excellent ride comfort and leveling. During sporty driving quattro drive for sweeping dynamics, high precision handling and superior directional stability on most surfaces makes. And the 7-speed dual clutch transmission S tronic for fast switching without any noticeable interruption of traction.

The fuel consumption and CO<sub>2</sub> emissions and efficiency categories, see page 56. In the illustrated and described equipment is partially about options at extra cost. Detailed information on standard and optional equipment available at [www.audi.de](http://www.audi.de) or your Audi partner.

## Kurze Bremsen sorgen für neue Antriebe.

Dynamics and efficiency. Two values that are highly complementary in the new Audi A7 Sportback. This is ensured by efficiency measures such as lightweight construction, efficiency wizard and innovative mild hybrid technology, with which the new Audi A7 Sportback is equipped. Combined with the combustion engine, the mild hybrid system wins through recuperation electrical energy which is stored for certain driving situations. For example, for an additional power boost or emissions free sliding in sailing mode.

The fuel consumption and CO<sub>2</sub> emissions and efficiency categories, see page 56. In the illustrated and described equipment is partially about options at extra cost. Detailed information on standard and optional equipment available at [www.audi.de](http://www.audi.de) or your Audi partner.





\_ 01

- 01 inter alia, front and rear bumpers \_ S-specific side rails painted in a striking, sporty design in body color \_ sill with aluminum insert front and rear lights, front lettering S
- 02 Radiator grille and side air intake grille in titanium black matt
- 03 S line-specific diffuser grating and painted matt black titanium

Many other highlights at [www.audi.de](http://www.audi.de)  
 The fuel consumption and CO<sub>2</sub> emissions and efficiency categories, see page 56. In the illustrated and described equipment is partially about options at extra cost.  
 Detailed information on standard and optional equipment available at [www.audi.de](http://www.audi.de) or your Audi partner.

Ma r he cant. Wi th the S  
 li ne teri ex eu r package.

Underline the sporty character of your Audi A7 Sportback not only - you can increase it. The optional S line exterior package and giving the dynamic lines even mitreißendere note and place with exceptional details special accents.



\_ 02



\_ 03



01



\_ 02 \_

# Sportlicher. Mit the S line Sportpaket.

Show up with the optional S line sports package from your dynamic page - across the board. With details that further sharpen the sporty character of the Audi A7 Sportback. Give the interior even more expression or define the chassis for enhanced driving dynamics even sportier. And you turn your Audi a real athlete.



\_ 03

01 front and rear illuminated sill with aluminum liner, in front with lettering S-

02 20-inch cast aluminum wheels, 5-twin-spoke design

03 forward \_ S line seat covers in optional leather Valcona front \_ S line sports steering wheel with multi-function \_ inlays brushed aluminum dark, etc. Sports seats with S-embossing in the backrests in rotor gray with contrast stitching, optionally in black \_ floor mats in black with piping and contrast stitching \_ footrest and pedals in stainless steel

Many other highlights at [www.audi.de](http://www.audi.de) The fuel consumption and CO<sub>2</sub> emissions and efficiency categories, see page 56. In the illustrated and described equipment is partially about options at extra cost. Detailed information on standard and optional equipment available at [www.audi.de](http://www.audi.de) or your Audi partner.

38

39



\_01

01 inter alia, with optional Individual contour front seats, optionally in leather Valcona sarderbraun with contrasting seams and piping in steel gray \_ double spoke steering wheel with multi-function and paddles

02 Wood applications Birch Burl achatgrau naturell \_ interior items in artificial leather sarderbraun with contrasting seams in steel gray

Many other highlights at [www.audi.de](http://www.audi.de)

The fuel consumption and CO<sub>2</sub> emissions and efficiency categories, see page 56. In the illustrated and described equipment is partially about options at extra cost. Detailed information on standard and optional equipment available at [www.audi.de](http://www.audi.de) or your Audi partner.

Blaupause - Inhalt\_FB 009 Schöndruck Yellow 1010160700800302  
01717:01:45 \$[ProcessCalCurve] Namelayout: Blaupause Black

Cyan Magenta Yellow

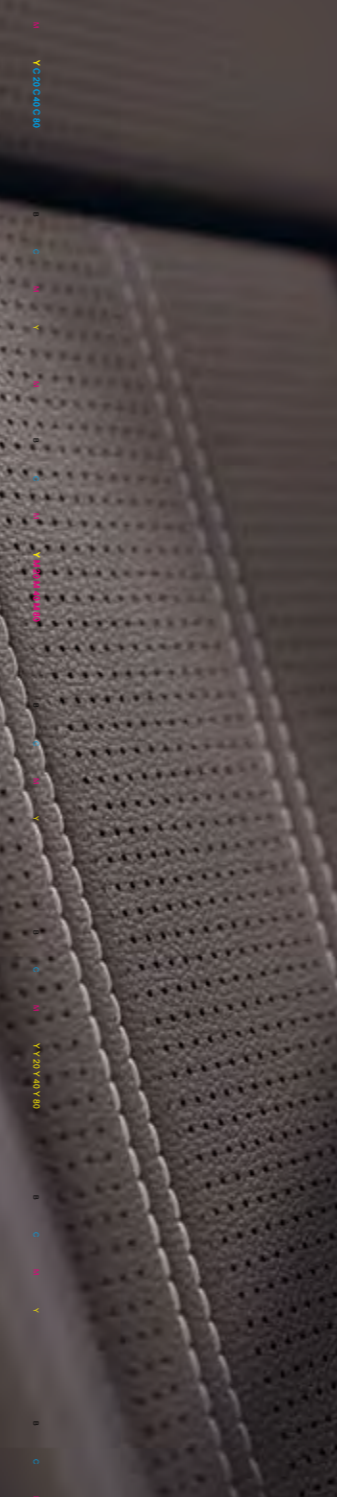

Outdoor Get used to it. With the Audi interior selection.

Make an extraordinary vehicle even more special. The Audi design selection exclusively in Sarderbraun or Junipergrau offers an aesthetic pre-selection of special materials and interior colors on request. High-quality inlays in conjunction with a noble leather trim and attractive contrast seams give the interior an exclusive ambience.

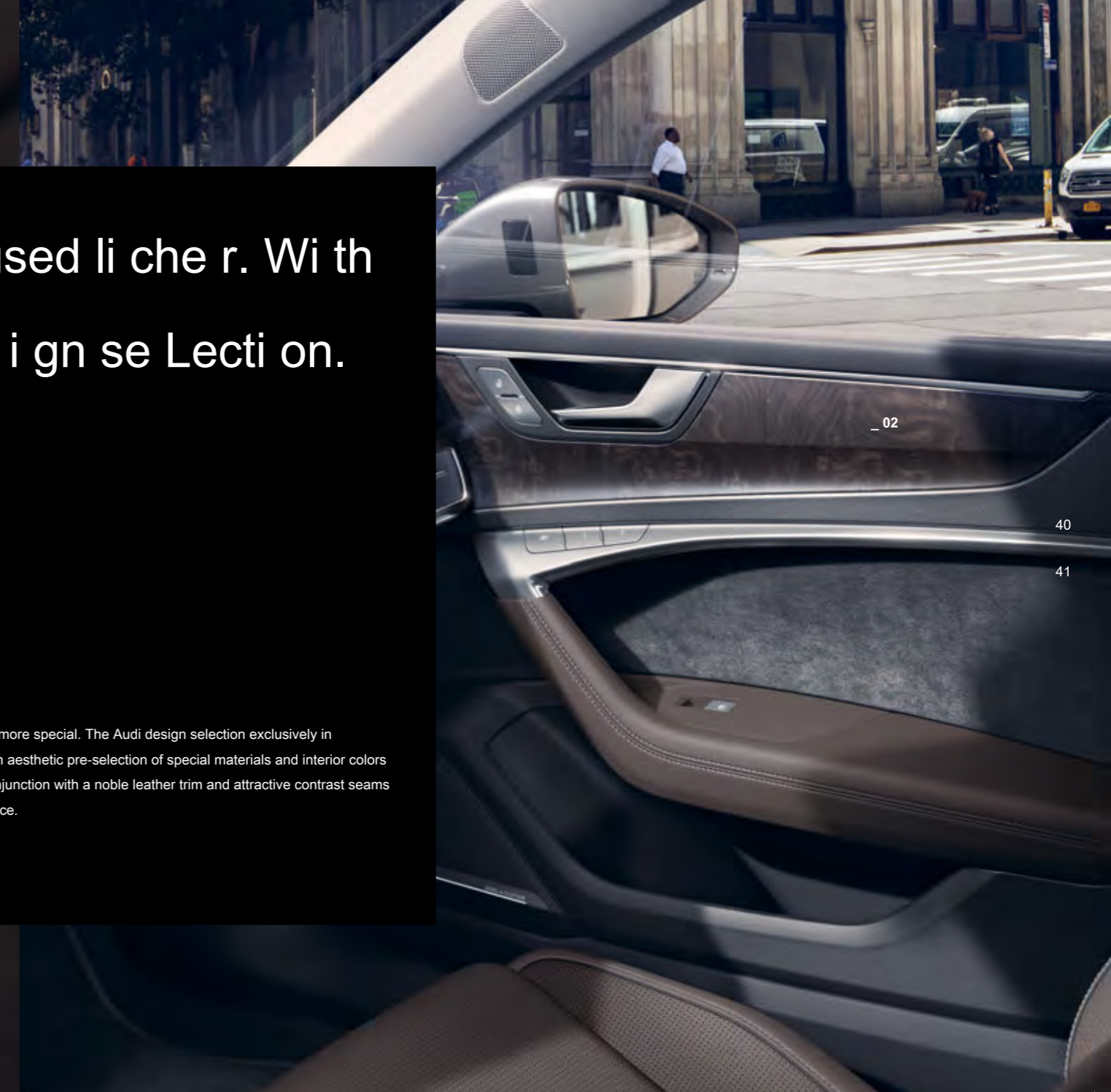

\_02

40

41

Unve r  
we CHSE I ba rer. With

Audi exclus i ve.

Turn your Audi A7 Sportback unique - as unique as you are - by Audi exclusive. With selected decors, colored leather and individual painting of a large range of colors. Just as you wish.



Audi A7 Sportback with Individual paint finish Audi exclusive Suzuka Metallic \_  
Cast aluminum wheels Audi Sport 5-V-spoke star design glossy anthracite  
Black, glanzgedreht'

The fuel consumption and CO<sub>2</sub> emissions and efficiency categories can be found on page 56. Audi exclusive is an optional offer of Audi Sport GmbH. Detailed information on standard and optional equipment available at [www.audi.de](http://www.audi.de) or your Audi partner. \* Please note the special to the wheels on page 57th



Leather upholstery - Main color Audi exclusive



Leather interiors - Additional colors for the instrument panel top, steering wheel and door sill Audi exclusive Valcona leather, alabaster white



Accent colors Audi exclusive

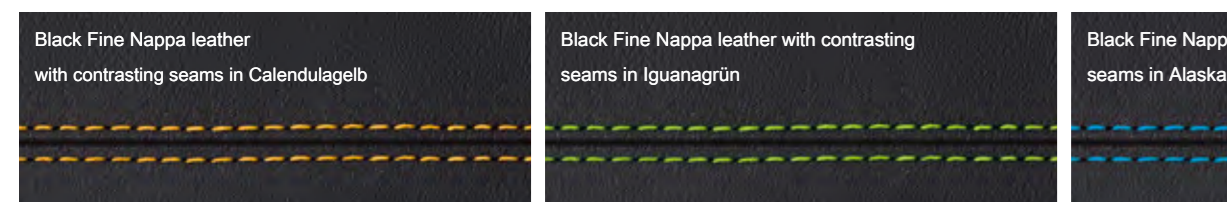

Wood applications Audi exclusive

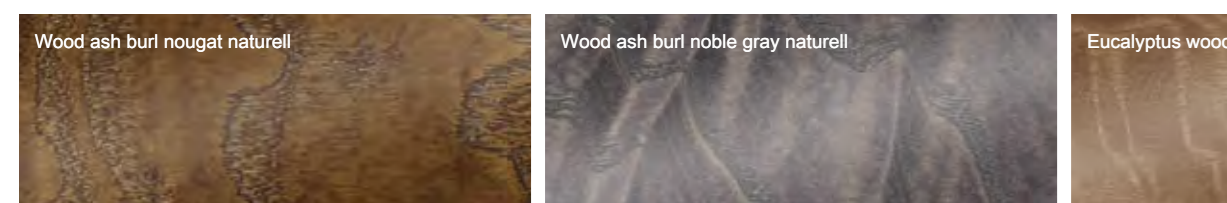

# Die Individualität der Audi exklusiven.

There is only one chance for a first impression. Take advantage of this and choose your own personal exterior paint from the wide color range of Audi exclusive. Here is a small selection.

Many other finishes at [www.audi.de](http://www.audi.de)



\_02

\_04

\_05

\_06

- 01 Suzuka Metallic
- 02 Ipanemabraun Metallic
- 03 Misano Red pearl effect
- 04 Arablau crystal effect
- 05 Goodwood Green pearlescent
- 06 Karat Beige Metallic

The fuel consumption and CO<sub>2</sub> emissions and efficiency categories can be found on page 56. Audi exclusive is an optional offer of Audi Sport GmbH. Detailed information on standard and optional equipment available at [www.audi.de](http://www.audi.de) or your Audi partner.

Leather seats in Valcona leather Audi exclusive \_ Controls in Audi exclusive leather \_ elements of an interior in leather top and bottom Audi exclusive and carpet and floor mats Audi exclusive diamond silver and ocean blue \_ top side of dashboard and door sill in jet gray with contrasting seams in ocean blue \_ Wood applications Audi exclusive wood ash burl noble gray temperament

# Starke Anblick.

Select the paint color that best suits your personality. You can rely on excellent quality, because your car is not simply painted, but four times. So you experience it not only brilliant, but your Audi is also protected against many environmental influences and wear. For a strong vision, the car's lifetime.

Many other finishes at [www.audi.de](http://www.audi.de)

\_02

\_03

\_04

\_05

\_06

\_07

- 01 Triton Blue Metallic
- 02 Vesuvius Gray Metallic
- 03 Avalon Green Metallic
- 04 Taifungrau Metallic
- 05 Firmament Blue Metallic
- 06 tangorot Metallic
- 07 Ibis White

finishes



\_01

The fuel consumption and CO<sub>2</sub> emissions and efficiency categories, see page 56. In the illustrated and described equipment is partially about options at extra cost. Detailed information on standard and optional equipment available at [www.audi.de](http://www.audi.de) or your Audi partner.

44

45

# S tar ke r Au ftritt.



- 01 19-inch cast aluminum wheels in 10-Y-spoke design
- 02 20-inch cast aluminum wheels in a 5-spoke design (S-Design)
- 03 21-inch aluminum forged wheels 5 V spoke star design, high contrast gray, teilpoliert<sup>1</sup>
- 04 20-inch cast aluminum wheels Audi Sport in 5-double-arm Design<sup>2</sup>, <sup>3</sup>
- 05 21-inch cast aluminum wheels Audi Sport in 5 V-spoke star Design<sup>2</sup>, <sup>3</sup>
- 06 20-inch cast aluminum wheels, 5-twin-spoke V design
- 07 21-inch cast aluminum wheels Audi Sport in 5 V-spoke star design in anthracite black shiny, glanzgedreht<sup>1</sup>, <sup>2</sup>, <sup>3</sup>

Audi wheels underline your individual style and character of your Audi A7 Sportback. Treat yourself to a particularly strong showing with your favorite design. For the good feeling of the road: Audi wheels are subjected to comprehensive testing procedures, charges are tested under intense and of enormous quality.

Many more wheels under [www.audi.de](http://www.audi.de)

Information on the technical characteristics of the tires, see page 57. The fuel consumption and CO<sub>2</sub> emissions and efficiency categories, see page 56. In the illustrated and described equipment is partially about options at extra cost. Detailed information on standard and optional equipment available at [www.audi.de](http://www.audi.de) or your Audi partner.

<sup>1</sup> Please note the special to the wheels on page 57. <sup>2</sup> An offer of Audi Sport GmbH. <sup>3</sup> The exact implementation date please find out from your Audi partner.

# Hochwertige Materialien und Ausstattung für Sie. Mit dem Stoff und der Lederkombi.



In your Audi take a special place. On the front and rear seats impressive comfort is palpable: high-quality materials and first-class workmanship. Regardless of what seat cover you choose, you are sitting correctly.

Many other seat covers at [www.audi.de](http://www.audi.de)

S sports seats in Valcona leather, black with contrasting seams in rock gray and S-Prägung\*



Individual contour seat, front, in Valcona leather pearl beige with piping and contrasting seams in Agate gray

\* The exact implementation date please find out from your Audi partner, or your Audi partner.

Information on standard and optional equipment available at [www.audi.com](http://www.audi.com). Described equipment is partially about options at extra cost. Detailed

Valcona leather with black diamond quilting. In the examples shown and



Woven effect black

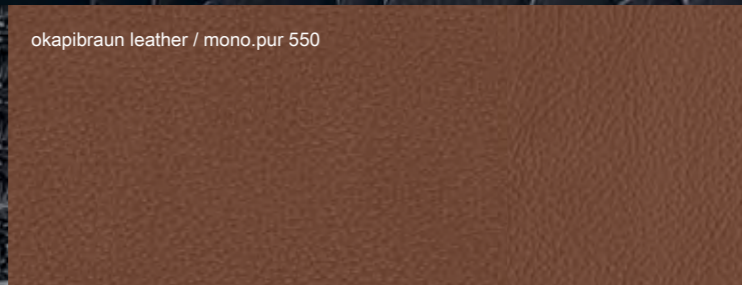

okapibraun leather / mono.pur 550



Alcantara / leather combination metropolitan gray

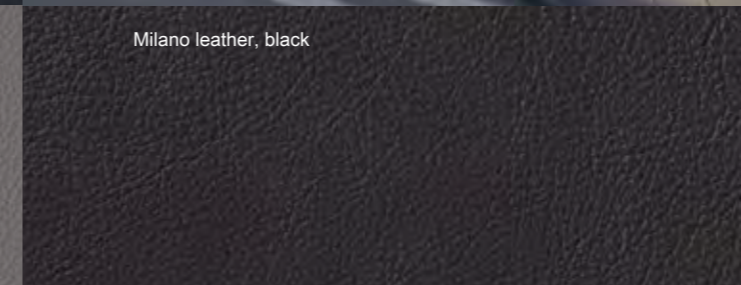

Milano leather, black

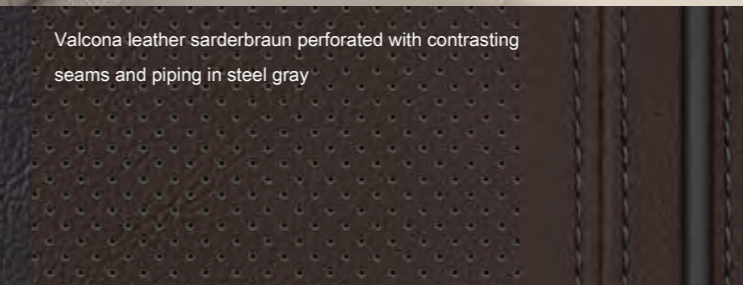

Valcona leather sarderbraun perforated with contrasting seams and piping in steel gray

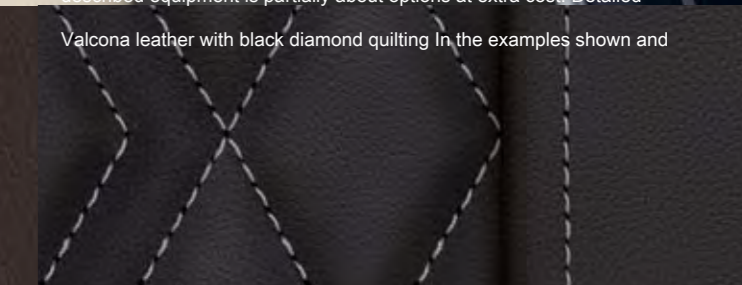

Selected. With the

Inlays.

\_01

\_02

\_03

\_04

Exclusive ambience is a matter of style. Her style. You can refine every detail. Put sensible accents with the high-quality Audi inlays. Experience the fascination of selected materials: fine woods or aluminum decors - combine individually according to your personal taste.

Many other inlays under [www.audi.de](http://www.audi.de)

- 01 aluminum fragment
- 02 Matt brushed aluminum dark
- 03 Wood Walnut naturell
- 04 Wood ash grain gray natural brown

In the illustrated and described equipment is partially around options at extra cost. Detailed information on standard and optional equipment available at [www.audi.de](http://www.audi.de) or your Audi partner.

So i nd ivi due ll wi s your life.

Progressive design and sporty elegance - your Audi A7 is characterized by a spectacular course that can be highlighted with Audi Genuine Accessories also. Put more statements with visual and functional highlights and enjoy additional comfort in the midst of urban cities or on winding country roads. High-quality Audi Genuine Accessories matched to the design language of your A7.

The fuel consumption and CO<sub>2</sub> emissions and efficiency categories, see page 56th

<sup>1</sup> Please note the special to the wheels on page 57. <sup>2</sup> information on the technical characteristics of the tires, see page 57th

**05 ski and luggage (360 l)** - in the exclusive Audi design.

Available in 2 colors and 3 sizes. Moreover displayed: roof boxes bags (3 different sizes) and the matching base support.

**06 cast aluminum wheels** - in the 5-arm FalxDesign, matte black, shiny gedreht<sup>1</sup>, in the dimension 8 x J 21, 255/35 R 21<sup>2</sup>.

**01 Inductive Charging Case** - for wireless charging of Apple iPhone 5-7 generations. After iPhone directive from Apple (MFi) certified.

**03 entry-level LED** - projecting the Audi rings or the quattro logo with LED light onto the substrate.

**02 all-weather floor mats** - protect the vehicle interior against wet and very dirty. With A7 logo.

**04 Winterkomplettträder** - Cast aluminum wheels in 5-arm Ramus-design, glossy black, 8.5 J x 20, 245/45 R 19<sup>2</sup> 102V M + S XL.

Audi Genuine Accessories

52

53



Faszination Audi A7 Sportback. Mehr von ihnen online.



Explore the world of the new Audi A7 Sportback. More information and more individuality and more exclusivity. Now on [www.audi.de/a7](http://www.audi.de/a7).

Scan the QR code with a smartphone or tablet and discover the world of the new Audi A7 Sportback. Link cost according mobile phone contract

<b>model</b>	<b>A7 Sportback 55 TFSI 250 kW (340 hp)</b>
engine type	V6-cylinder petrol engine with direct fuel injection, Mild Hybrid Electric Vehicle (MHEV)
Displacement in cc (valves per cylinder)	2.995 (4)
Max. Performance <sup>1</sup> in kW (hp) at n min <sup>-1</sup>	250 (340) / 5000-5400
Max. Torque in Nm at min <sup>-1</sup>	500 / 1370-4500
<b>power transmission</b>	
Power unit	8-speed automatic transmission
Gearbox	8-speed automatic
<b>Weight / volume</b>	
Leergewicht <sup>2</sup> in kg	1890
Perm. Total weight in kg	2470
Perm. Roof load / nose weight in kg	90/95
Perm. Anhängelast <sup>3</sup> in kg unrestrained 12% slope at 8% gradient	750 2000 2000
Fuel tank capacity in l	63
<b>Performance / consumption<sup>4</sup> Top</b>	
Maximum speed in km / h	250 <sup>5</sup>
Acceleration 0-100 km / h in s	5.3
Fuel	Sulfur-free super RON 95 <sup>6</sup>
<b>Fuel consumption<sup>7</sup>, *1 / 100 km urban extra-urban combined</b>	9.3 to 9.1 5.9 to 5.4 7.2-6.6
<b>CO<sub>2</sub>-Emissionen<sup>7</sup>, * combined in g / km</b>	163-154
Efficiency / emission standard	B / EU6

**Explanations**

<sup>1</sup> The value given was determined (in the current version UN-R 85) according to the measuring methods.

<sup>2</sup> vehicle curb weight with driver (75 kg) and the fuel tank filled to 90%, determined according to the VO (EU) 1230/2012 in the current version. Optional equipment the empty weight and the air resistance coefficient can be increased, whereby the possible payload or maximum speed is reduced accordingly the vehicle.

<sup>3</sup> With increasing height inevitably decreases engine performance. At 1,000 m above sea level and 1,000 meters per additional 10% is subtracted from the combination weight (perm. Towable + perm. Total weight of the towing vehicle). Valid value towable with factory fitted tow bar. For commercial use of the vehicle with a tow you need a digital tachograph may under certain conditions.

<sup>4</sup> information on fuel consumption and CO<sub>2</sub> emissions and efficiency categories for clamping widths depending on the used tire / wheel set. <sup>5</sup> Governed.

<sup>6</sup> The use of unleaded fuel sulfur-free super RON 95 in accordance with DIN EN 228 is recommended. If not available, unleaded fuel standard sulfur free RON 91 in accordance with DIN EN 228 with slight reduction in performance. Fuel Unleaded RON 95 to a maximum ethanol content of 10% (E10) is basically usable. Fuel consumption details refer to operation with RON 95 fuel in accordance with 692/2008 / EC.

<sup>7</sup> The figures given were calculated using the specified measuring procedures. The figures do not refer to a specific vehicle and are not part of the offer but are purely for comparison purposes between the various types of vehicle. Further information on official fuel consumption and official specific CO<sub>2</sub> emissions for new passenger cars in the "Guidelines on fuel consumption, carbon emissions and power consumption of new passenger cars" are taken at all sales outlets and at DAT German Automobil Treuhand GmbH, Hellmuth- Hirth-Str. 1, 73760 Ostfildern-Scharnhausen (www.dat.de) is available free of charge. <sup>8</sup>s fuel consumption and CO<sub>2</sub> emissions of a vehicle do not just depend on the efficient utilization of the fuel by the vehicle, but are also influenced by driving behavior and other non-technical factors. CO<sub>2</sub> is mainly responsible for global greenhouse gas.

<b>Audi A7 Sportback</b>	Dimensions in mm
Dimensions were measured with vehicle at unladen weight. Gepäckraumvolumen <sup>1</sup> 535 / 1,390 l (second value is with the folded rear seat back and loaded to the roof). Turning circle 12.2 m approx.	
<sup>1</sup> Maximum headroom. <sup>2</sup> width elbow room. <sup>3</sup> shoulder width space.	

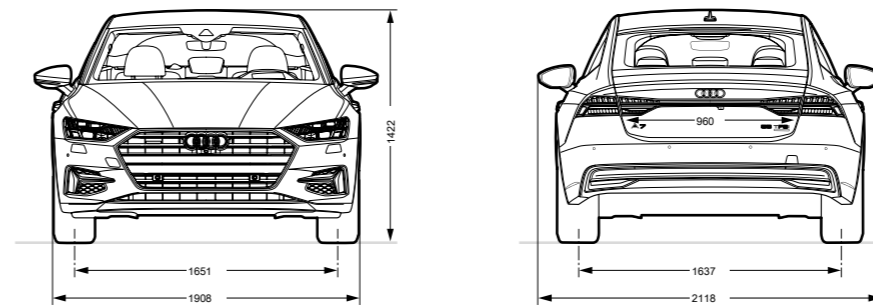
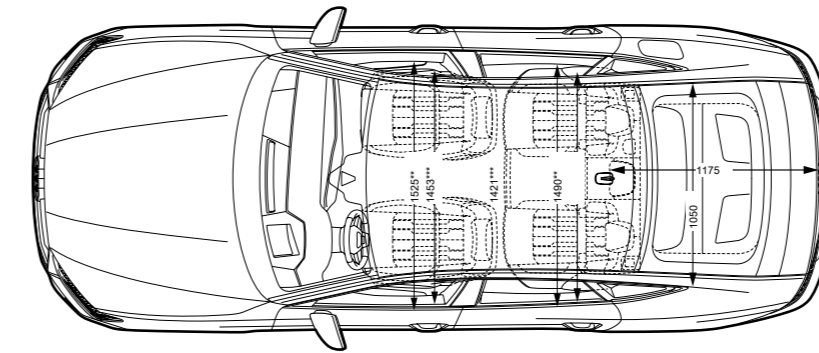
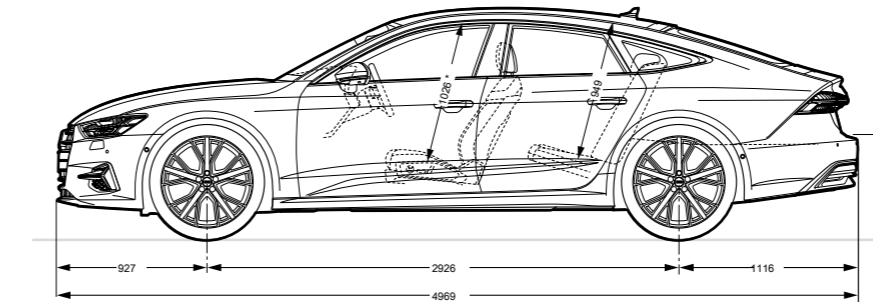

**Classifications of tire parameters**

The table lists the tightening of the fuel efficiency class, wet grip class and the class of the external rolling noise to different tire sizes of the Audi A7 Sportback.

	wheel size	Fuel efficiency class	Nasshaftungs-class	Class of the external rolling noise
summer tires	205/65 R 17	B	B	71
	225/55 R 18	B-A	A	72-68
	245/45 R 19	B	A	70
	255/40 R 20	C	B-A	71-70
winter tires	225/55 R 18	C	B	69
	245/45 R 19	C	B	70-69
	255/40 R 20	C	B	71-69
All-season tires	225/55 R 18	B	A	69

The appointment of a specific tire is not possible.

**Important instructions**

**Special features of the wheels:** Sheen, gloss machined, polished or part polished aluminum wheels may not be used in winter road conditions. The rim surface does not have sufficient corrosion protection due to manufacturing and can be permanently damaged by road salt or the like.

**life vehicle recycling:** All Audi models are dismantling and recycling meet constructed. At the same time, AUDI AG further developed the framework for the utilization of old vehicles and their components and to reduce the waste to be disposed constantly. Further information can be obtained on the Internet at www.audi.de under the keywords "old car" and "car wreck." Information on nearby collection points for correct recycling according Altfahrzeuggesetz you get also on the Internet and via our free hotline 0800 2834737 and from your Audi partner.

Equipment for the Audi A7 Sportback (page 2-33): Paint: Triton Blue Metallic wheels: forged aluminum wheels in 5-V-spoke star design, contrasting gray, teilpoliert<sup>2</sup> seats / seat covers: Individual contour seats in Valcona leather junipergrau perforated with contrasting seams in rock gray inlays: aluminum fragment

The fuel consumption and CO<sub>2</sub> emissions and efficiency categories, see page 56th

<sup>1</sup> Technical specifications relate to a basic vehicle without country-specific ratios and selected optional equipment. <sup>2</sup> Please note the special features of the wheels on this page.



**AUDI AG**

Auto-Union-Straße 1 85045  
Ingolstadt [www.audi.de](http://www.audi.de)

Date: November 2017

Printed in Germany 733 /  
1250.71.00

The vehicles shown in this catalog and described are partially equipped with options at extra cost. All data regarding delivery, appearance, performance, dimensions and weights, fuel consumption and running costs is correct to the time of going to press skills. We reserve the right of the figures, errors and misprints variations in color and shape. All details of equipment and specifications based on the characteristics of the German market. Subject to change. Reproduction in whole or part, without the written approval of AUDI AG.

The paper of this Kata logs made from chlorine-free pulp.

