

A8



2004 Audi A8 L Sedan Product Information





- 4.2L V8 engine with:
 - 330 hp (20 hp increase from the 2003 model)
 - 317 lb-ft of torque (15 lb-ft increase from 2003 model)
- 6-speed Tiptronic Transmission
- quattro IV all-wheel drive
- Multi-Media Interface (MMI) including 7" color screen
- Completely re-engineered Audi Space Frame
- Driver adjustable full air suspension
- World-class Bose[®] Premium Sound System featuring Audio Pilot[™] noise cancellation technology
- Benchmark interior design with new colors and wood trims



4.2L V8 Engine Features:

- 330 hp @ 6,500 rpm
- 317 lbs-ft. @ 3,500 rpm
- Aluminum engine block
- 5-valve technology
- DOHC
- Two-stage intake manifold (shown lower left)
- 7% increase in fuel efficiency (estimated)
- Multi-stage catalytic converters

Two-stage Intake Manifold

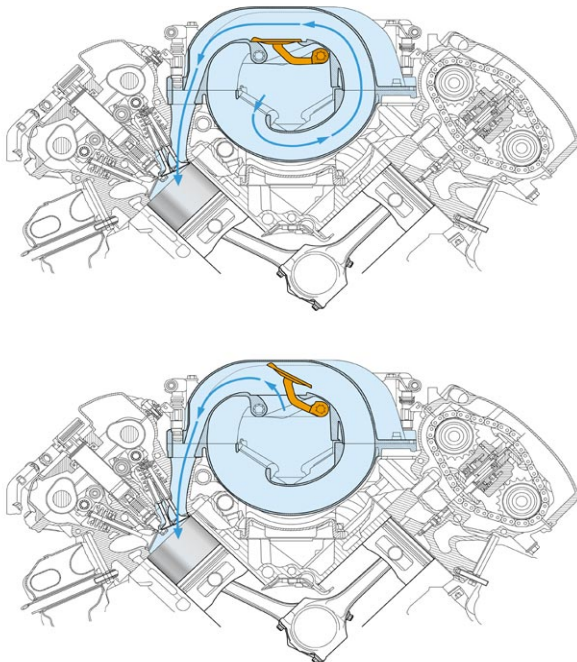

Torque / Horsepower curves

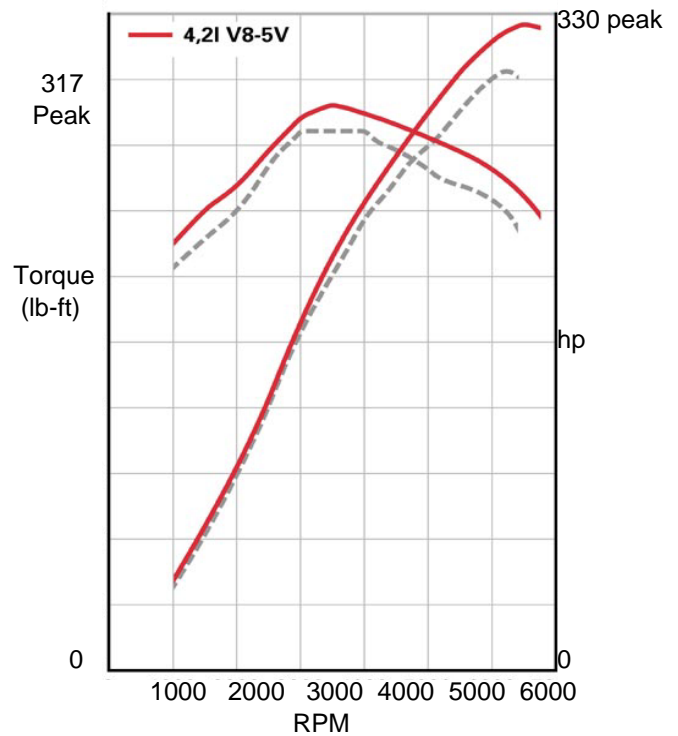

Audi 6-Speed Tiptronic Transmission

Features/Benefits

- 6-Speed Tiptronic Transmission (replaces 5-speed in 2003 model year)
- 30% wider gear spread than the five-speed version it replaces, allowing:
 1. Improved low end torque
 2. Increased fuel efficiency
- Less power dissipation
- Dynamic Shift Program (DSP) automatically adjusts to driver's driving style
- Sport Program can be selected on shifter
- New for the 2004 model year

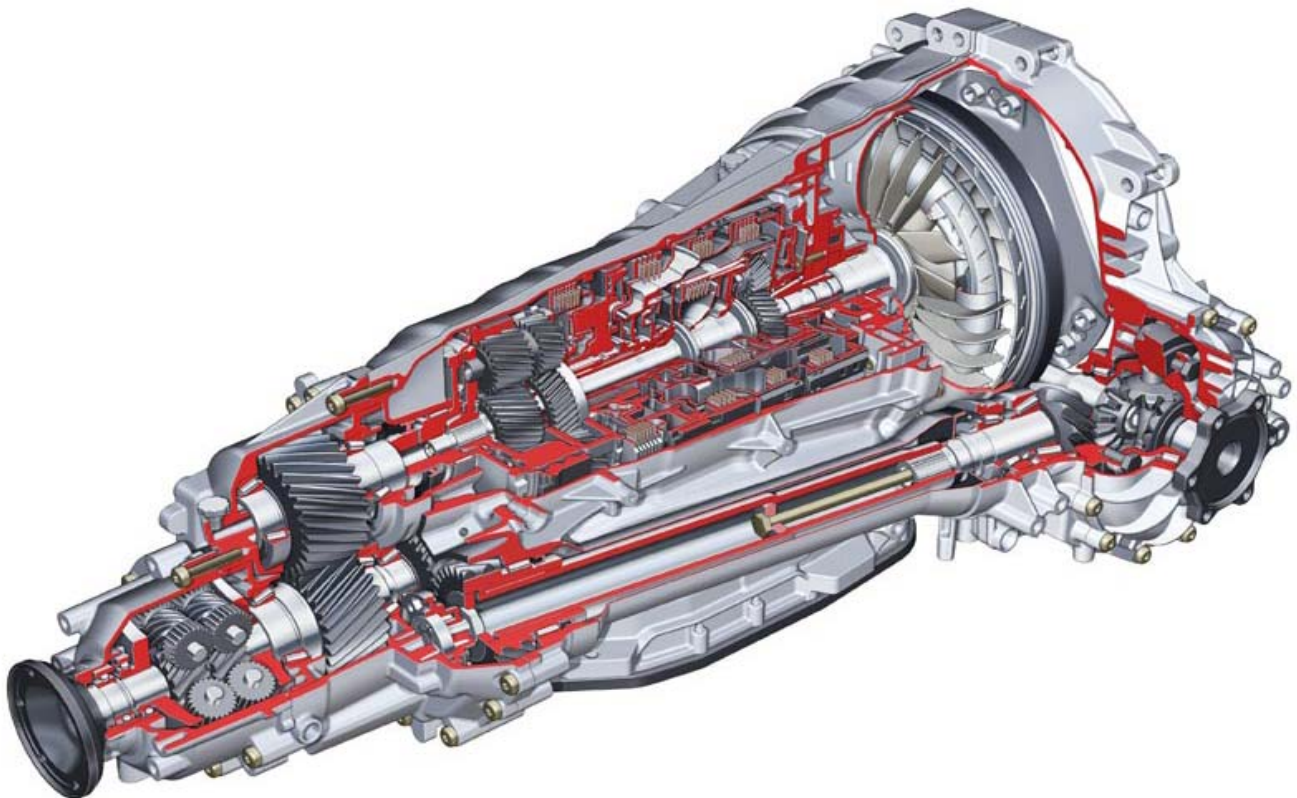

The 6-speed Tiptronic transmission is the exclusive transmission used on the Audi A8 L

Audi Space Frame (ASF III) Completely redesigned for the 2004 model year

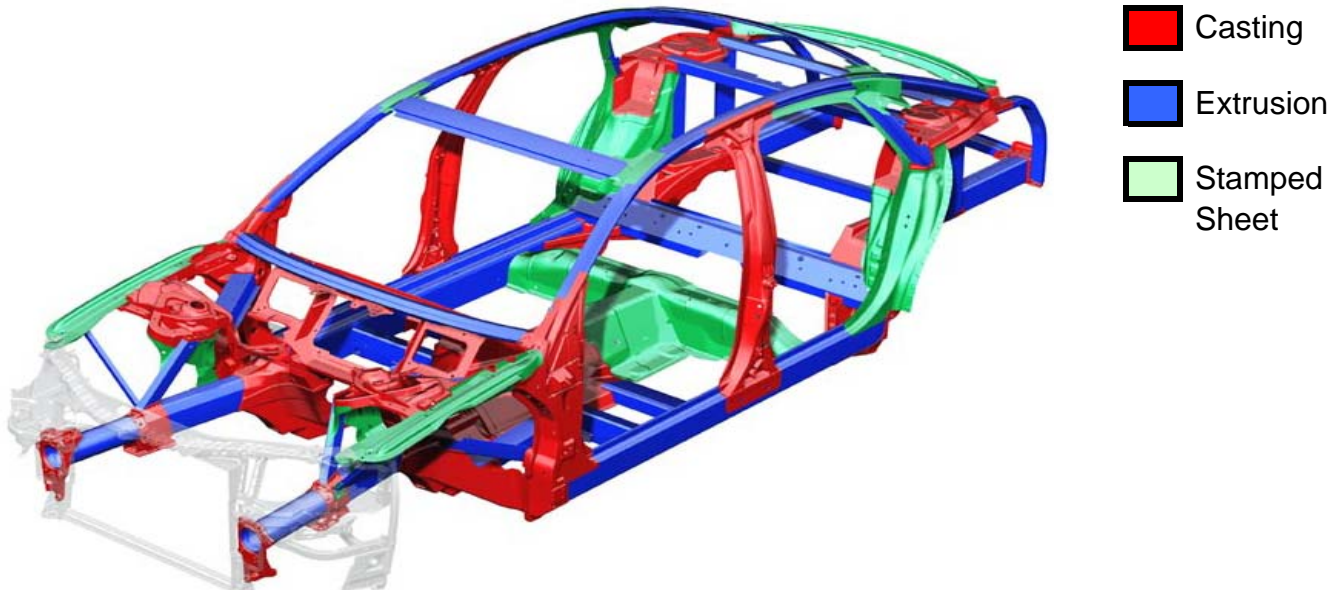

Improvements over previous version of the Audi Space Frame:

- 60% Increased Rigidity
- 17% Less Parts
- 300 lb weight savings vs. conventional steel frame, thereby improving handling
- New laser-hybrid welding technique developed for better quality / more efficient welds

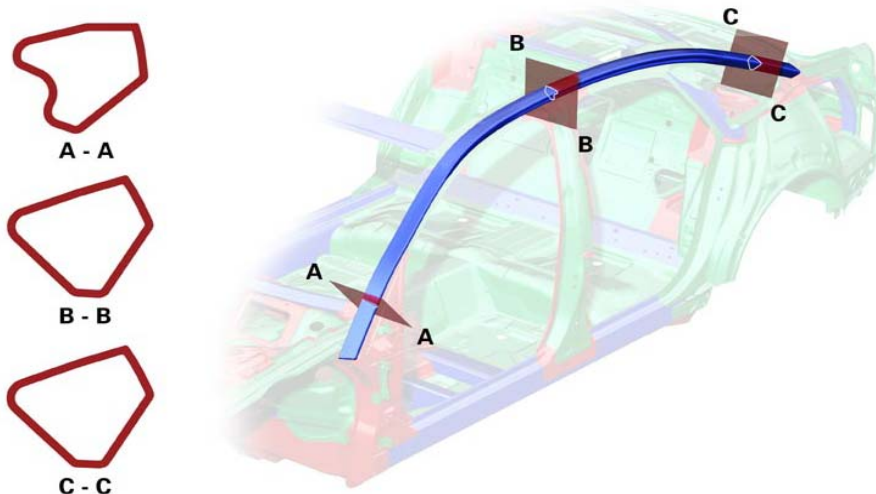

Extrusions

Hydroforming processes allow Audi to use extrusions with varying cross-sections. This enables the perfect cross-section design to be used at all points along the extrusion, thereby increasing strength and rigidity while enhancing functionality.



- Infinitely adjustable adaptive damping system
- Air spring struts at each wheel
- Automatic self-levelling regardless of load
- Variable ground clearance (depending on driver's setting choice)

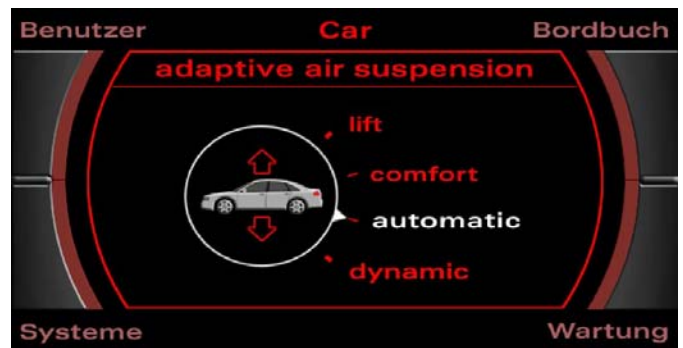

Adaptive Air Suspension

- **Lift Mode**
- **Comfort Mode**
- **Automatic Mode**
- **Dynamic Mode**

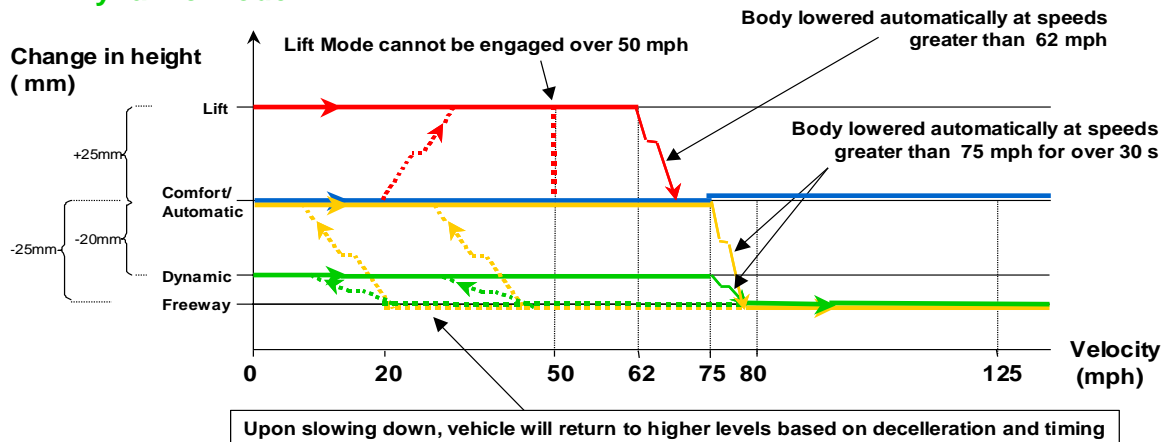



The A8 L features a variety of interior design features:

- "Hide-away" 7-inch color Multi-Media Interface (MMI) screen - see photos
- Multi-Media Interface (MMI) control panel in center console
- Premium Comfort Seats with high-grade Valcona leather and 16-way adjustability
- Dual cupholders located in center console
- 6-CD changer in glove box
- New generation 4-spoke steering wheel with MMI controls
- New Birch wood trim (pictured above, standard on Beige interiors)
- 12-speaker Premium Bose Sound System w/subwoofer and Surround Sound
- Interior ambient lighting package (standard)
- Additional large color screen in instrument panel used with steering wheel controls
- DVD-based Audi Navigation System with large screen map display
- Audi Telematics by Onstar (with one-year Safe&Sound Package standard)

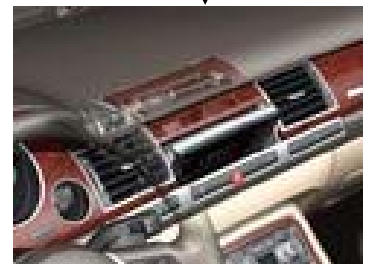

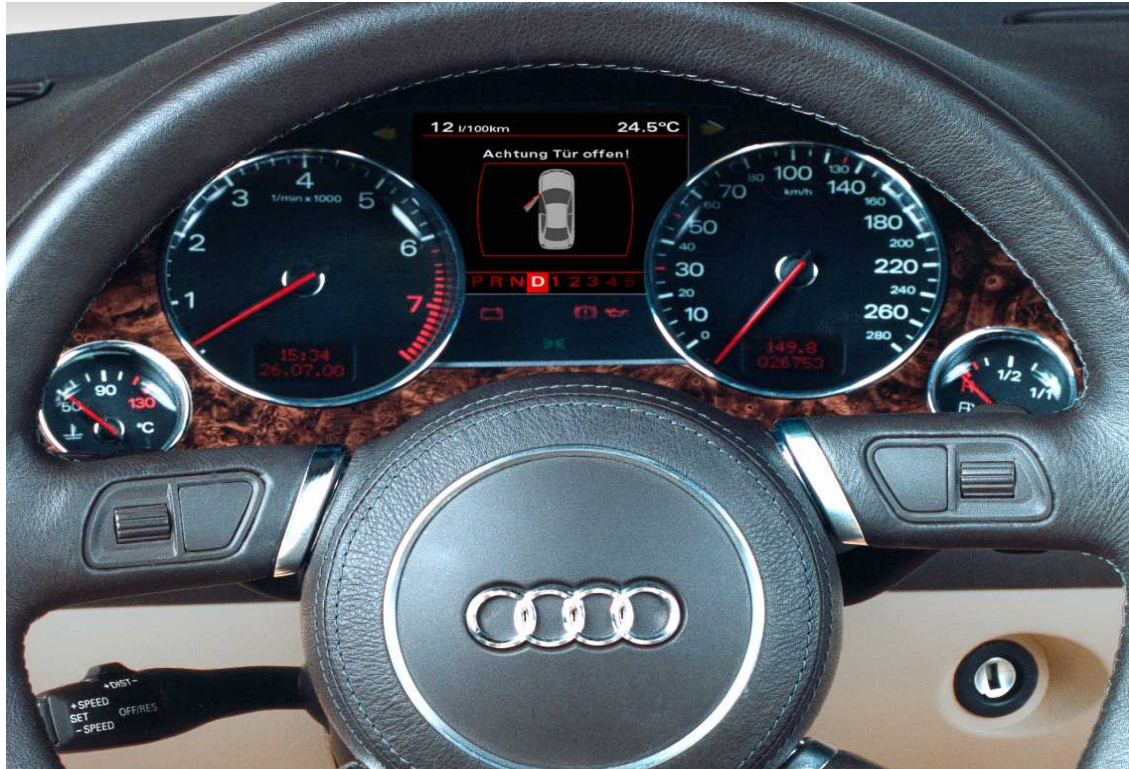

MMI functions can be controlled from the steeringwheel controls (above) or the center console (right). The MMI buttons shown control the radio, CD, navigation, and almost all vehicle settings - greatly minimizing the number of buttons necessary in the interior.

MMI functions can be viewed from two separate screens depending on driver preference:

1. In the main instrument cluster (shown below left)
2. The 7" screen located in the center console (shown below right). This screen can be electronically stowed for reduced driver distraction.



Bose 12-Speaker Premium Surround Sound System

Features

- ◆ Standard equipment on 2004 Audi A8 L
- ◆ 12-Speakers including 12-inch woofer
- ◆ Surround Sound capability
- ◆ Bose AudioPilot electronic noise cancellation technology
- ◆ DSP (Digital Signal Processing)

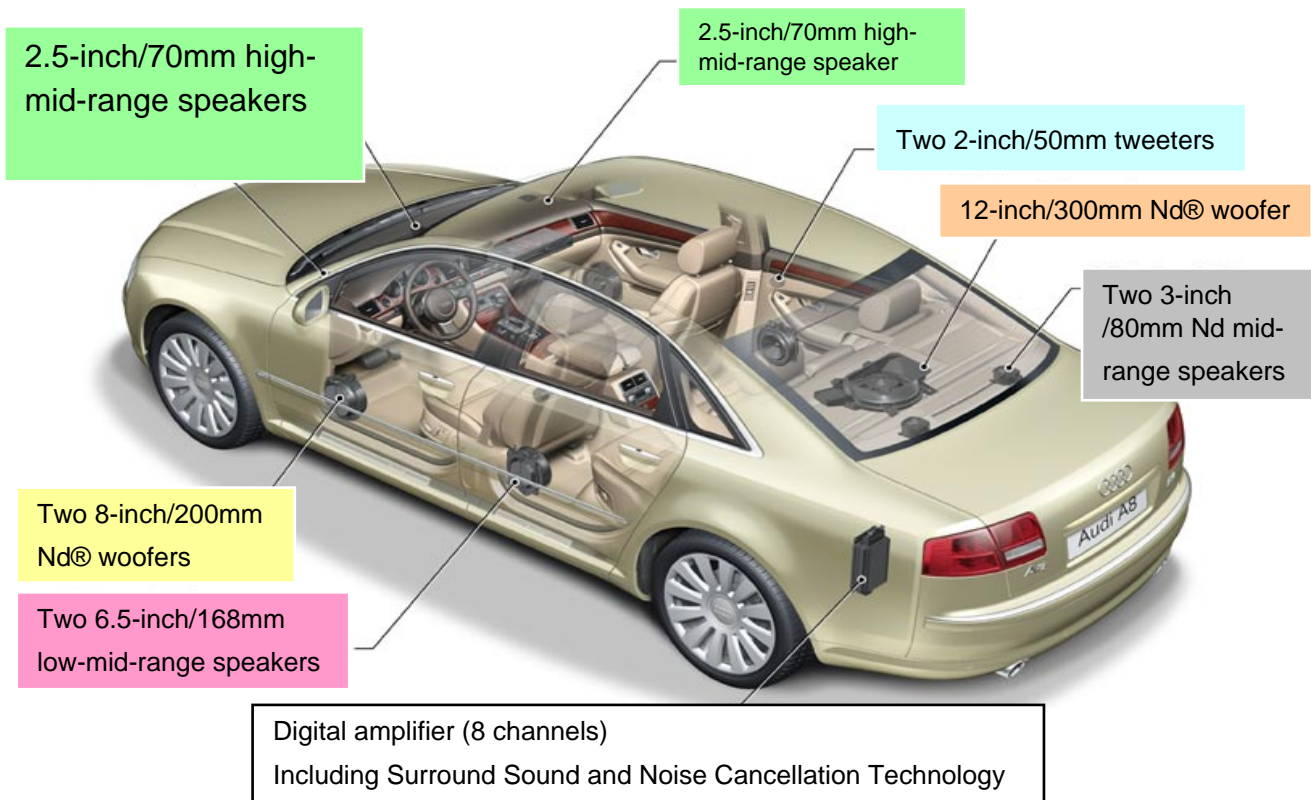

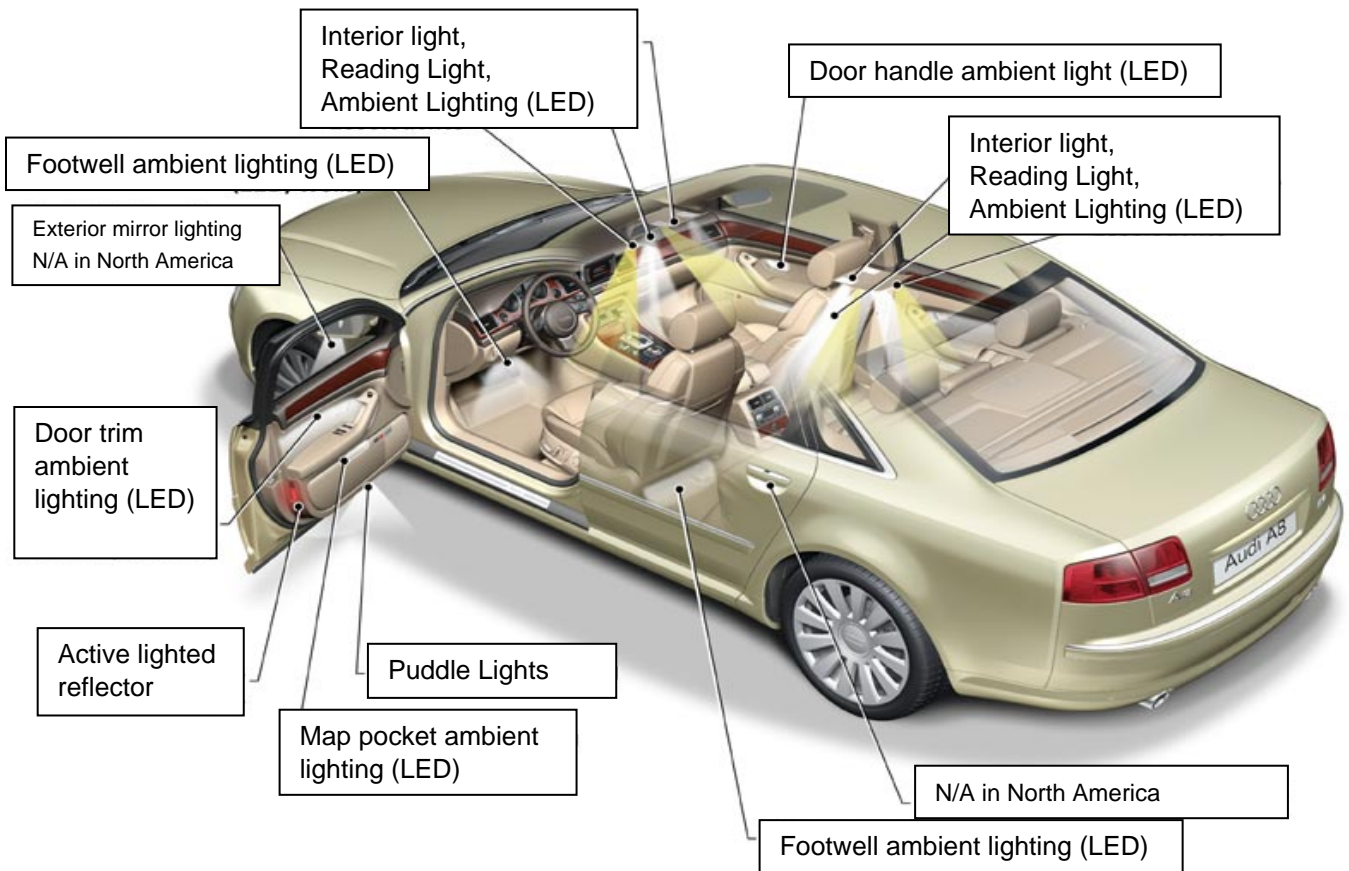

Audi's use of LED technology is prevalent in both the interior ambient lighting as well as extensive use in the rear tail lights.



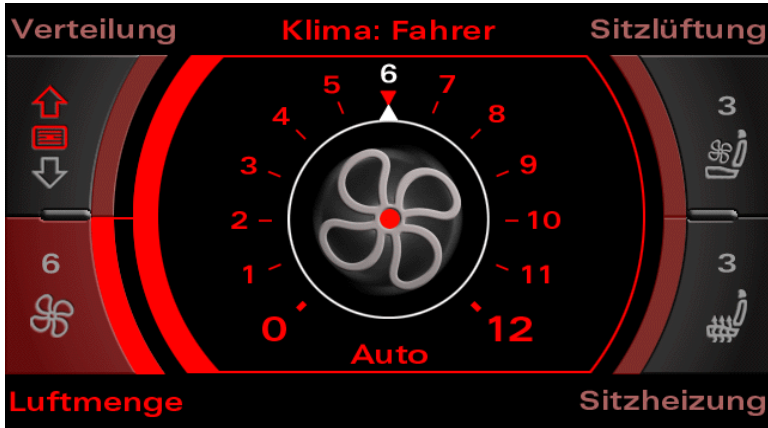

Climate settings are initiated from a control panel independent from the MMI controls. However, when adjusting these controls, the 7" MMI screen is used for display purposes. (example shown to the left).

A generous number of registers (shown to the right), allow each front seat passenger to control their own temperature settings by engaging the dual zone climate controls.

Also available is a four zone climate control system which allows rear seat passengers the same capabilities.

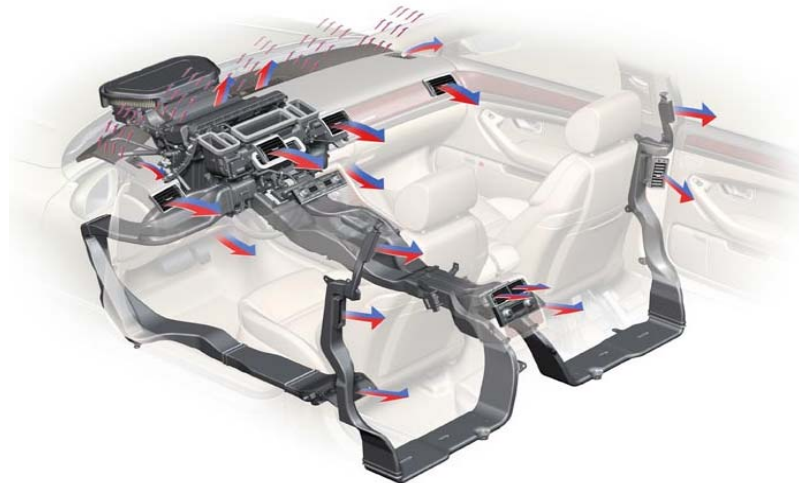

Attention to detail is an Audi hallmark. Notice how air is reheated just before the reaching the rear seat footwells. (shown to the left)



Audi partners with OnStar to telematics bring services to our customers. Services include:

Safe&Sound Package

- Airbag deployment notification
- Emergency services
- Remote door unlock
- Vehicle theft tracking
- Roadside Assistance
- Remote Vehicle Alert

Directions&Connections Package

- All in Safe&Sound, plus:*
- Route support
 - Convenience services
 - Ride Assist

Luxury&Leisure Package

- All in Directions&Connections plus:*
- OnStar Concierge

Available with any package are two additional services: Personal Calling and Virtual Advisor.

Virtual advisor is a stream of user-definable data, such as weather, news, etc; downloaded to the vehicle.

One year of safety and security package is standard with the telematics option.

The new Audi-Motorola Digital telephone is now available on vehicles equipped with telematics. The phone includes following features:

- 400 Memory Phonebook
- Text messaging
- Turbo dialing
- Voice notes
- Voice activating dialing
- Wireless Web browser
- Predictive text
- Voice recognition enabling hands-free use in the vehicle

Digital Talk Time: 150 mins / Standby: 150 hours



2004 Audi A8 L
Equipment

Legend x = Standard o = Optional p = Package	A8 L 4.2 quattro®
Technical	
<ul style="list-style-type: none"> • Newly redesigned aluminum alloy space frame and body panel construction • 4.2 liter DOHC aluminum alloy 330 hp 90 degree V8 engine, 5-valves per cylinder, variable intake magnesium manifold with 2 intake paths, direct ignition system, roller camshaft followers, variable intake camshaft timing • 6-speed automatic transmission with Tiptronic® and DSP (selects from over 200 shift programs to match driver's needs), hill detection capability and "Sport-mode" setting • quattro® IV - permanent all-wheel drive system, includes Torsen® torque sensing center differential • Anti-lock brake system (ABS 5.3) with front and rear Electronic Differential Locks (EDL) and Electronic rear Brake force Distribution • ESP 5.7 - Electronic Stabilization Program • CFC-free (ChloroFlouroCarbon) air conditioning refrigerant 	x x x x x x x
Wheels / Tires / Suspension / Steering	
<ul style="list-style-type: none"> • 7-spoke 8J x 17 inch cast-alloy wheels with 235/55 R 17 all-season tires • 5-spoke 8.5J x 18 inch polished alloy wheels with 255/45 R 18 all-season tires • 12-spoke 8.5J x 19 inch polished alloy wheels with 255/40 R 19 performance tires • Full size spare tire with alloy wheel • Servotronic® - vehicle speed-sensitive power rack & pinion steering • Leather covered 4-spoke steering wheel with audio controls (in dashboard color) • Pneumatic air suspension at all four wheels • Electrically adjustable tilt and telescopic steering wheel with automatic tilt-away for ease of entry and exit • Heated steering wheel 	x o o x x x x x p
Exterior	
<ul style="list-style-type: none"> • Body color outside mirrors; left side flat, right side convex • Auto dimming outside rearview mirrors • Dual pane laminated "acoustic" glass for all windows • 5 MPH (Federal standard) bumpers, painted in body color • Exterior chrome beltline trim • Protective side moldings, chrome/body color combination • Body color door handles • Heatable windshield washer nozzles • Metallic or pearl effect paint at no extra charge 	x x o x x x x x x
Exterior (Continued)	
<ul style="list-style-type: none"> • Nomenclature: <ul style="list-style-type: none"> - Four rings on center rear of trunk lid - "A8 L" on left rear of trunk lid - "4.2" on right rear of trunk lid - "quattro" on right rear of trunk lid - Four rings in center of grille - "quattro" on left side of front grille • Tinted glass, dark tinted band around edge of windshield 	x x x x x x x

Exterior Lighting	
<ul style="list-style-type: none"> ● Xenon high intensity, low and high beam headlights with automatic self-leveling ● Two front fog lights located in lower front bumper ● Two rear fog lights in portion of taillights located on the decklid ● High pressure headlight washers, retractable, flush with bumper ● Red taillight lenses with red LED's used as the turn signals ● "Puddle" lights in all four doors ● Front clear lenses w/amber turn lights, amber DRL lenses, and side markers w/amber bulbs 	<ul style="list-style-type: none"> x x x x x x x
Interior Lighting	
<ul style="list-style-type: none"> ● Interior lights in front and rear headliner with fade-in and fade-out feature, time delay and automatic switch on when key is withdrawn from ignition ● Front and rear reading lights located in headliner ● White ambient LED lighting in headliner for front center console illumination ● Illumination for interior door release handles ● Front and rear footwell lights ● Illuminated glove box, trunk, lighter and ashtray 	<ul style="list-style-type: none"> x x x x x x
Comfort and Convenience	
<ul style="list-style-type: none"> ● Fully automatic dual zone climate control system with "Rest" function (heater can operate when vehicle shut-off), dual sun sensors and smog sensor with activated charcoal filter ● Power glass sunroof with both tilt and slide functions, "pre-select" function, convenience closing system with pinch protection ● Solar sunroof ● Power windows with: <ul style="list-style-type: none"> - power retention (until either front door open) - "one-touch down" for all four windows - "pinch protection" for all four windows (reverses window at force >100N) - "one touch up" for all four windows - driver controlled lock out switch for rear power windows ● Electronic cruise control with coast, resume and speed-up features ● Dual power outside mirrors with defog feature ● Electrical rear window defogger with automatic timed shut off feature ● Power central locking system (doors, deck lid and fuel door), with selective unlocking (enables unlocking of a single door or all doors), plus: <ul style="list-style-type: none"> - convenient close feature for windows & sunroof (functions by holding key in lock position) - master switch located in all doors - convenient open for windows (functions by holding key in unlock position) ● Multi-function steering wheel with MMI controls ● Heated steering wheel ● Audi Navigation System w/large 7" color screen display (uses DVD technology) ● HomeLink® 3 channel remote transmitter located in headliner console ● Fuel tank release button in driver's door ● Trunk lid release button in driver's door 	<ul style="list-style-type: none"> x x o x x x x x x p x x x x

**2004 Audi A8 L Sedan
Option Program**

Legend	A8 L
x = included in package o = Optional	4.2 quattro®
Optional Equipment	
<ul style="list-style-type: none"> ● Convenience package 	o
- Front Seat Ventilation	x
- Rear Seat Vanity Mirrors	x
- Tire Pressure Monitoring System	x
- Power trunk open/close	x
- Electric Rear Sunshade	x
<ul style="list-style-type: none"> ● Cold Weather package 	o
- Heated front and rear seats, adjustable in 6 steps (Front heated seats standard in Canada)	x
- Heated Steering Wheel	x
- Ski sack	x
Separate options	
● 18" wheel with all-season tires	o
● 19" wheel with performance tires	o
● Solar sunroof	o
● Acoustic Parking	o
Separate options "Sold Orders Only" (Items can be ordered only on sold orders)	
● Dual-Paned Security Glass	o
● Front Seat Massage	o
● Rear Seat Electric lumbar	o
● Dual Rear seat climate control	o
● Door armrest in leather + Center Console w/Premium stitching	o
● Alcantara package	o
● Adaptive Cruise Control	o



7-spoke cast alloy wheels

8J x 17 ET 43

- Standard
235/55 R 17 99 H All-Season Tires

Michelin Pilot HX-MXM 4

Pirelli P6 Four Seasons



5-spoke cast alloy wheels

8.5J x 18 ET 45

- Optional
255/45 R 18 99 H All-Season Tires

Conti TouringContact CH 95

Pirelli P6 Four Seasons



12-spoke cast alloy wheels

8.5J x 19 ET 45

- Optional
255/40 R 19 100 Y Performance Tires

Bridgestone Potenza RE 040

Pirelli P Zero Rosso

Interior

**E
x
t
e
r
i
o
r**

	Black	Black/ Amaretto	Platinum	Blue	Beige	Beige/ Lt. Beige
	LA	LR	LF	LS	LV	LW
Brilliant Black A2A2	Available	Available	Available	N/A	Available	Available
Light Silver metallic 5B5B	Available	Available	Available	Available	Available	Available
Night Blue pearl effect 7X7X	N/A	Available	Available	Available	Available	Available
Platinum Beige pearl effect 7Z7Z	Available	Available	Available	N/A	Available	Available
Northern Blue pearl effect 9U9U	Available	Available	Available	Available	Available	Available
Sage Green metallic 3G3G	Available	N/A	Available	N/A	Available	N/A
Burgundy Red pearl effect H4H4	Available	Available	Available	N/A	Available	Available
Oyster Gray metallic X1X1	Available	Available	Available	Available	Available	Available
Arctic White B5B5	Available	N/A	Available	Available	Available	N/A
Atlas Gray metallic 4A4A	Available	Available	Available	Available	Available	N/A
Irish Green pearl effect	Available	Available	Available	N/A	Available	Available

Technical Specifications		2004 Audi A8 L Sedan	
ENGINE:			
Type	DOHC aluminum alloy 90 degree V8, ULEV exhaust standard		
Arrangement	Front mounted, longitudinal		
Bore	3.33 in.	84.5 mm	
Stroke	3.66 in.	93 mm	
Displacement	255 cu. in.	4172 cc	
Compression ratio	11.0 : 1		
Fuel requirement	Premium unleaded 91 AKI / 95 RON recommended for maximum performance		
Horsepower (SAE)	330 hp	@ 6500 rpm	
Torque	317 lb.-ft.	@ 3500 rpm	
ENGINE DESIGN:			
Cylinder block	Aluminum alloy		
Crankshaft	Forged steel, 5 main bearings		
Cylinder head	Aluminum alloy		
Valve train / intake	DOHC, hydraulic valve lifters, two-stage variable intake manifold		
Firing order	1 - 5 - 4 - 8 - 6 - 3 - 7 - 2		
Cooling system	Water-cooled, thermostatically controlled radiator fan		
Lubrication system	Gear pump, pressurized, full flow with oil cooler		
Fuel injection / Ignition system	Fully electronic engine management utilizing Bosch Motronic® ME7.1.1., sequential injection with adaptive idle-charge control, acceleration enrichment, overrun fuel cut-off, adaptive lambda control, mapped ignition with solid-state high-voltage distribution via single spark coils, cylinder selective adaptive knock control with two sensors		
Emission system	Dual 3-way catalytic converters w/individual oxygen sensors		
ELECTRICAL SYSTEM:			
Battery	12 volts	95 amp/hr	
Alternator	14 volts	190 amp	
DRIVETRAIN:			
Transmissions	• 6-speed Tiptronic transmission		
Type	quattro all-wheel drive		
	6-speed Tiptronic transmission		
Gear ratios:	1st	4.171:1	
	2nd	2.340:1	
	3rd	1.521:1	
	4th	1.143:1	
	5th	0.867:1	
	6th	0.691:1	
	Final Drive	3.317:1	
	Reverse	3.403:1	
Front Differential	Hypoid gear, electronically locking (EDL)		
Center Differential	TORSSEN® (TORque SENsing) differential providing automatic and variable front to rear power proportioning		
Rear Differential	Hypoid gear, electronically locking (EDL)		
STEERING:			
Type	Maintenance-free rack-and-pinion steering with Servotronic variable speed-based power assist		
Turns (lock-to-lock)	2.8		
Turning circle (curb-to-curb)	41.0 ft.	12.5 m	
SUSPENSION:			
Fully Pneumatic	Air Suspension Struts at all four wheels.		
	Air Strut damping characteristics are continuously adjusted via sensors.		
	Four driver-activated suspension settings (Dynamic, Comfort, Lift, and Automatic)		
BRAKES:			
Service brake	Dual circuit brake system with diagonal split, Anti-lock Brake System (ABS), Electronic Brake Distribution (EBD) and Electronic Stabilization Program (ESP); tandem brake booster		
Front, size and type	14.2 in.	360x34 mm	- Ventilated disc
Rear, size and type	12.2 in.	310x22 mm	- Ventilated disc
Parking brake	Electro-mechanically actuated at the rear wheels		

Technical Specifications (continued) 2004 Audi A8 L 4.2 Sedan

WHEELS:	Standard 17" (CG0)	Optional 18" (CG3)	Optional 19" (CG4)
Size	8J x 17	8.5J x 18	8.5J x 19
Offset	43 mm	45 mm	45 mm
Weight	11,500 g / 25.3 lbs	12,800 g / 28.2 lbs	11,100 g / 24.5 lbs
Type	Cast alloy	Cast alloy	Cast alloy

TIRES:	Standard 17" (HA7)	Optional 18" (HG7)	Optional 19" (H4L)
Size	235 / 55	255 / 45	255 / 40
Speed rating	H	H	Y
Construction	Radial	Radial	Radial
Load Index	99	99	100
Brand / Type (all approved)	Pirelli P6 Four Seasons	Conti TouringContact Ch 95	Bridgestone Potenza RE 040 (performance tire)
	Michelin Pilot HX-MXM 4	Pirelli P6 Four Seasons	Pirelli P Zero Rosso (performance tire)

BODY:

Material	Audi Space Frame construction (aluminum alloy) with aluminum alloy body panels
Corrosion protection	Multi-step anti-corrosion protection

CAPACITIES:

	quattro all-wheel drive	
Engine oil	8 qt.	7.5 liter
Fuel tank	23.7 gal.	90 liter
Cooling system	12.15 qt.	11.5 liter

EXTERIOR DIMENSIONS:

	Front wheel drive					
Wheelbase	121.1 in.	3075 mm				
Track: front / rear	64.1 in.	1629 mm	/	63.6 in.	n.a.	1615
Overall length	204.0 in.	5181 mm				
Overall width / with mirrors	74.6 in.	1894 mm	/	79.8 in.		2028 mm
Height (unloaded)	57.3 in.	1455 mm				
Ground clearance (loaded)	4.72 in +/- 1 in	120 mm +/- 25 mm		*** Ground clearance is dependent on Suspension Mode setting		
Curb weight	4399 lbs.	1995 kg				
Distribution % front / rear	56.4 / 43.6					
Drag coefficient	Cw = 0.27 Frontal Area = 2.31 sq. m.					

INTERIOR DIMENSIONS (SAE measurements):

Seating Capacity	5					
EPA class	Large					
Head room front / rear	39.1 in.	993 mm	/	38.6 in.	981 mm	(Note: AoA A8 L not available without sunroof)
w/sunroof front / rear	37.4 in.	951 mm	/	38.3 in.	974 mm	
Shoulder room front / rear	59.1 in.	1500 mm	/	57.5 in.	1460 mm	
Leg room front / rear	41.3 in.	1049 mm	/	42.3 in.	1075 mm	
Interior volume front / rear	52.8 cu. ft.		/	54.0 cu. ft.		106.8 = total interior cu. ft
Luggage Capacity	17.7 cu. ft.	500 liters				

PERFORMANCE:

	quattro all-wheel drive	
	6-speed Tiptronic	
0-50 mph (0-80kmh)	4.8 sec.	
0-60 mph (0-100 km/h)	6.3 sec.	
1/4 mile	14.2 sec.	
Top speed	Top speed is electronically limited at 130 MPH (208 km/h)	

FUEL ECONOMY: EPA estimate

	quattro all-wheel drive	
	6-speed Tiptronic	
City	17 mpg	
Highway	24 mpg	
Combined	20 mpg	

FUEL ECONOMY: Canadian Estimate

	6-speed Tiptronic	
City	13.5 liters/100km	
Highway	8.9 liters/100km	

**2004 Audi A8 L Sedan
Competitors**



BMW 745i
\$68,500/\$69,195*
4.4L, 4,376 lbs.
325 hp @ 6100 rpm
330 ft-lbs @ 3600 rpm
Rear Wheel Drive

BMW 745Li
\$72,500/\$73,195*
4.4L, 4,464 lbs.
325 hp @ 6100
330 ft-lbs @ 3600
Rear Wheel Drive



Mercedes S430
\$73,320*
4.3L, 4,160 lbs.
275 hp @ 5750 rpm
295 ft-lbs @ 3000 rpm
Rear Drive or 4-Matic

S500
\$81,720*
5.0L, 4,170 lbs.
302 @ 5600
339 @ 2700
Rear or 4-Matic



Lexus LS 430
\$55,500*
4.3 L, 3,945 lbs.
290 hp @ 5600 rpm
320 ft-lbs @ 3400 rpm
Rear Wheel Drive



Infiniti Q45
\$52,545*
4.5 L V8
340 hp @ 6400 rpm
333 ft-lbs @ 4000 rpm
Rear Wheel Drive



Jaguar XJ
\$56,975
4.0L V8
290 hp @ 6100 rpm
290 ft-lbs @ 4250 rpm
Rear Wheel Drive

* Includes destination