

Draining ATF and filling up after repairs

Procedure

- Engine not running.
 - Vehicle must be absolutely horizontal (drive it onto a four pillar lifting platform or over an inspection pit).
 - Selector lever at position „P“.
 - Parking brake button must be pulled up to apply the electromechanical parking brake.
- Remove noise insulation (rear) -2- →Rep. gr.66.

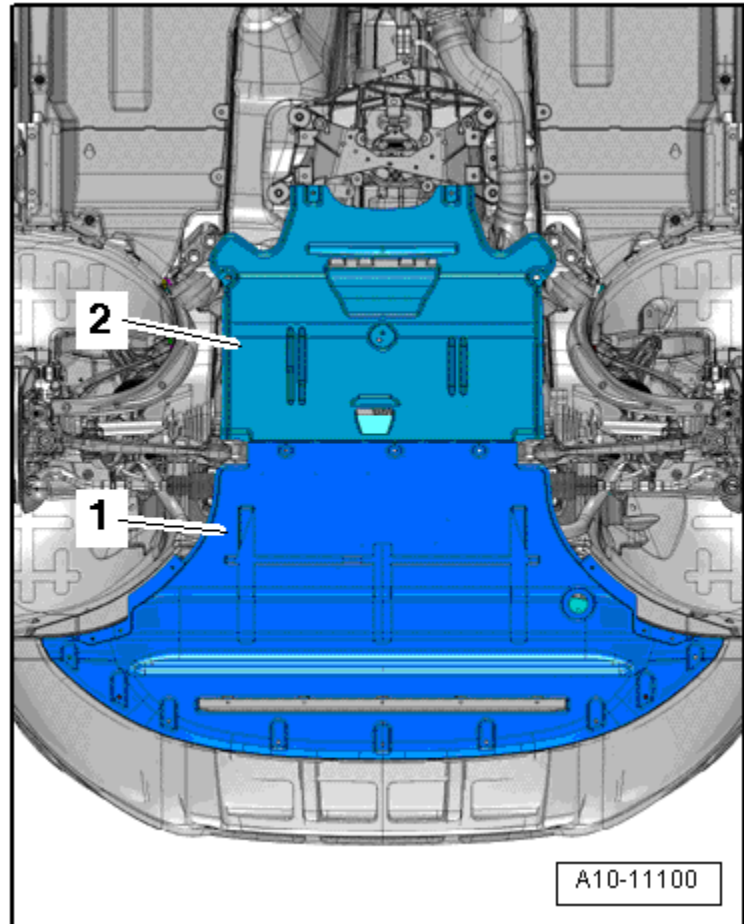

- Place used oil collection and extraction unit -V.A.G 1782- below gearbox.

**WARNING**

Risk of eye injury.

Wear safety goggles.

- Remove ATF drain plug -arrow A- and allow ATF to drain off.

**Caution**

Risk of damage to gearbox

The engine must not be started when there is no more ATF in the gearbox.

**Note**

- ◆ Always adhere to waste disposal regulations.
- ◆ Renew ATF drain plug with seal.
- Tighten new drain plug -arrow A- to 12 Nm.

Filling gearbox with ATF**Caution**

Risk of damage to gearbox

- ◆ **Only the ATF available as a replacement part may be used for the automatic gearbox 0B6.**
- ◆ **Other types of oil cause malfunctions and/or failure of the gearbox.**
- ◆ **For the correct type, refer to → [Electronic parts catalogue](#).**
- ◆ **The ATF filling unit must be clean and the ATF must not be mixed with other types of oil!**

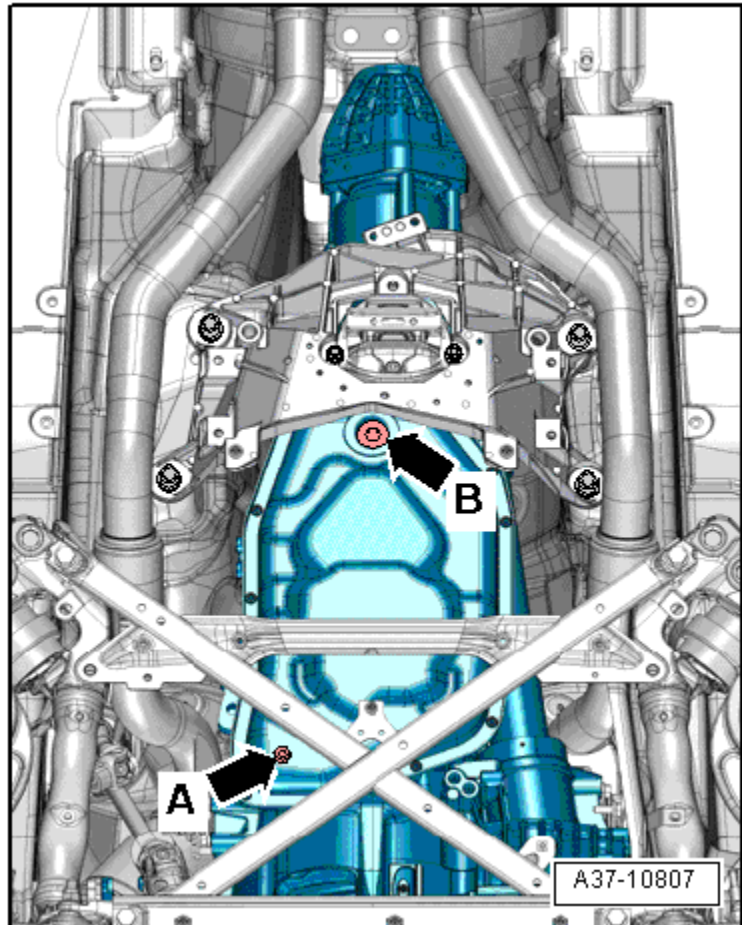

- Fill reservoir of ATF filling unit -V.A.G 1924- with ATF for automatic gearbox 0B6. For ATF specification refer to → [Electronic parts catalogue](#).
- Secure reservoir for ATF filling unit - V.A.G 1924- as high as possible on vehicle.

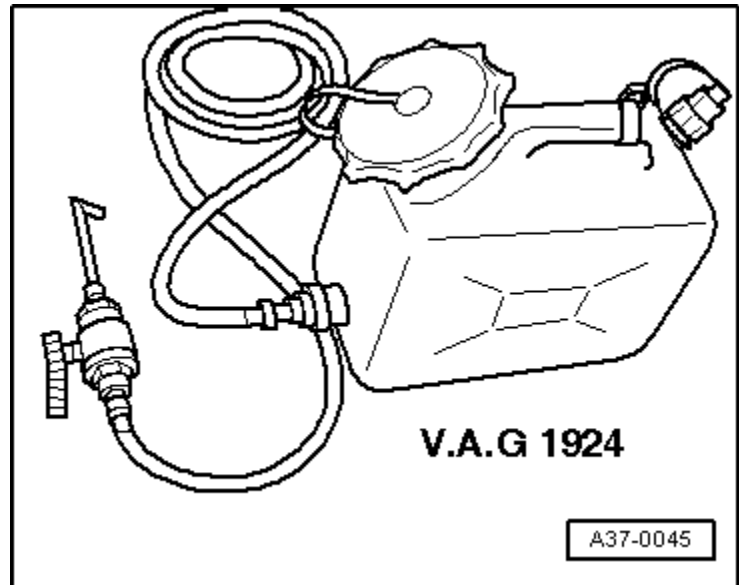

- Remove ATF inspection plug -arrow B-

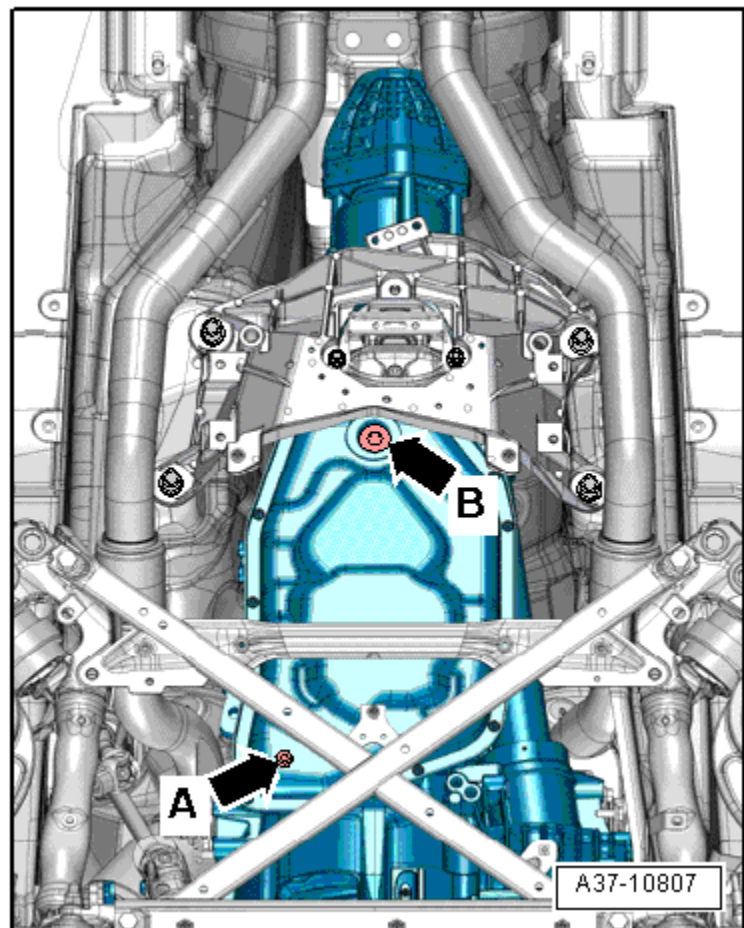

- Guide filler nozzle of ATF filling unit -V.A.G 1924- in from below through an opening in the deflector cap -arrow-, taking care not to push the deflector cap upwards out of position.
- Fill with ATF using ATF filling unit -V.A.G 1924- until ATF comes out of inspection hole.
- Shift selector lever into position „P“.
- Start engine and turn off after 20 seconds.
- Continue filling with ATF using ATF filling unit -V.A.G 1924- until ATF comes out of inspection hole.
- Start engine.
- Continue filling with ATF using ATF filling unit -V.A.G 1924- until ATF comes out of inspection hole again.
- Tighten ATF inspection plug.
- With brake pedal depressed, select all gear positions („P“, „R“, „N“, „D“, „S“) one after the other at idling speed, maintaining each position for at least 10 seconds.
- Shift selector lever into position „N“.
- Increase engine speed to 2000 rpm for at least 60 seconds.
- Shift selector lever into position „P“.
- Check ATF level and top up as required
→ Chapter.

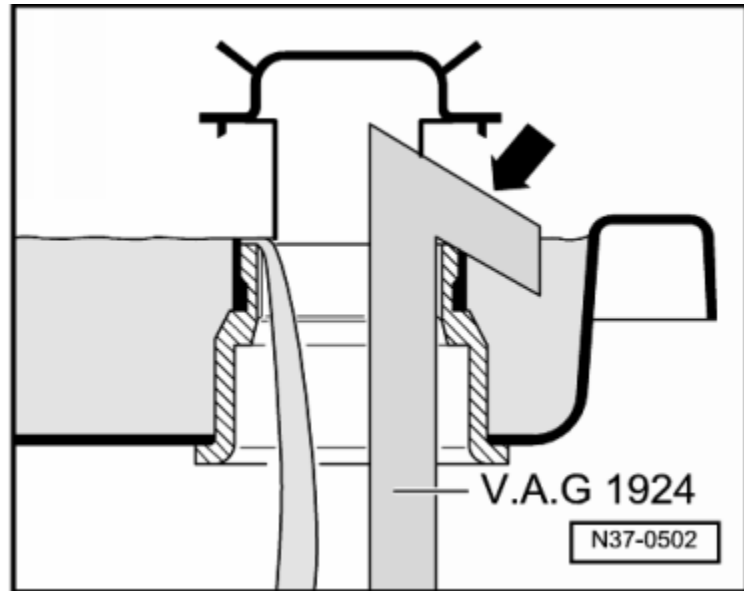

Note

Observe all notes and test requirements for „Checking ATF level“.

- Install rear noise insulation →Rep. gr.66.