

***AUDI MMI INTERFACE STEP BY STEP INSTRUCTIONS:**

1. Remove the trunk liner
2. Replace the trunk handle to our camera handle (have to remove license plate frame)
3. **This step is for Manual transmission only:** Tap provided wire into the reverse signal wire (black with grey strip, see page 9.) in the trunk on right side (or left for Australian cars), then run it to the glove box along with Camera Extension Video/Power cable, then see step 18.
4. At the trunk: Connect RCA trunk handle camera cable and DC red wires together. (See page 2.)
5. Run Extension Camera Video/Power cable to the glove box.
6. Remove AMI from the glove box, **need Audi Radio Removal tool**
7. Remove glove box (as shown in the video on our website)
8. Remove head unit, **need Audi Radio Removal tool (See page 3.)**
9. Disconnect the original LVDS cable from the head unit and connect it to our interface unit, run cable into the glove box (See page 5.)
10. Connect the supplied LVDS cable to the head unit and to our interface unit, run cable into the glove box
11. Connect CAN-bus/Power harness into our interface unit.
12. Run the CAN-bus/Power harness behind the glove box to the fuse box on passenger's side. **(For Australia – Driver's Side)**
13. Connect ACC to any A5 fuse in the black row/fuse panel. (See page 7.) **We highly advise you to use ATC tap fuse connector. Not provided. See pic 10.**
14. Connect Ground wire under 13 mm nut (See page 7.)
15. Switch CAN-bus connector (Beige Plug) at the fuse box (See page 7.)
16. Connect Input Wires Connector into our Interface Unit (See page 8.)
17. Connect Purple power wire with red wire from Camera Extension Video/Power cord (See page 2.)
18. Connect RCA video connectors.
19. **This step is for Manual transmission only:** Connect White Trigger wire with provided wire tapped into the reverse signal light.
20. Test it, Enjoy and Drive Safe!

*** WE TAKE NO RESPONSIBILITY FOR ANY DAMAGE YOU MAY DO TO YOUR VEHICLE FOLLOWING THESE INSTRUCTIONS, THE INFORMATION IS SUPPLIED AS A GUIDE ONLY!!!**

WE ADVISE YOU THAT INSTALLATION WAS DONE BY A PROFESSIONAL.

CAMERA WIRE CONNECTIONS

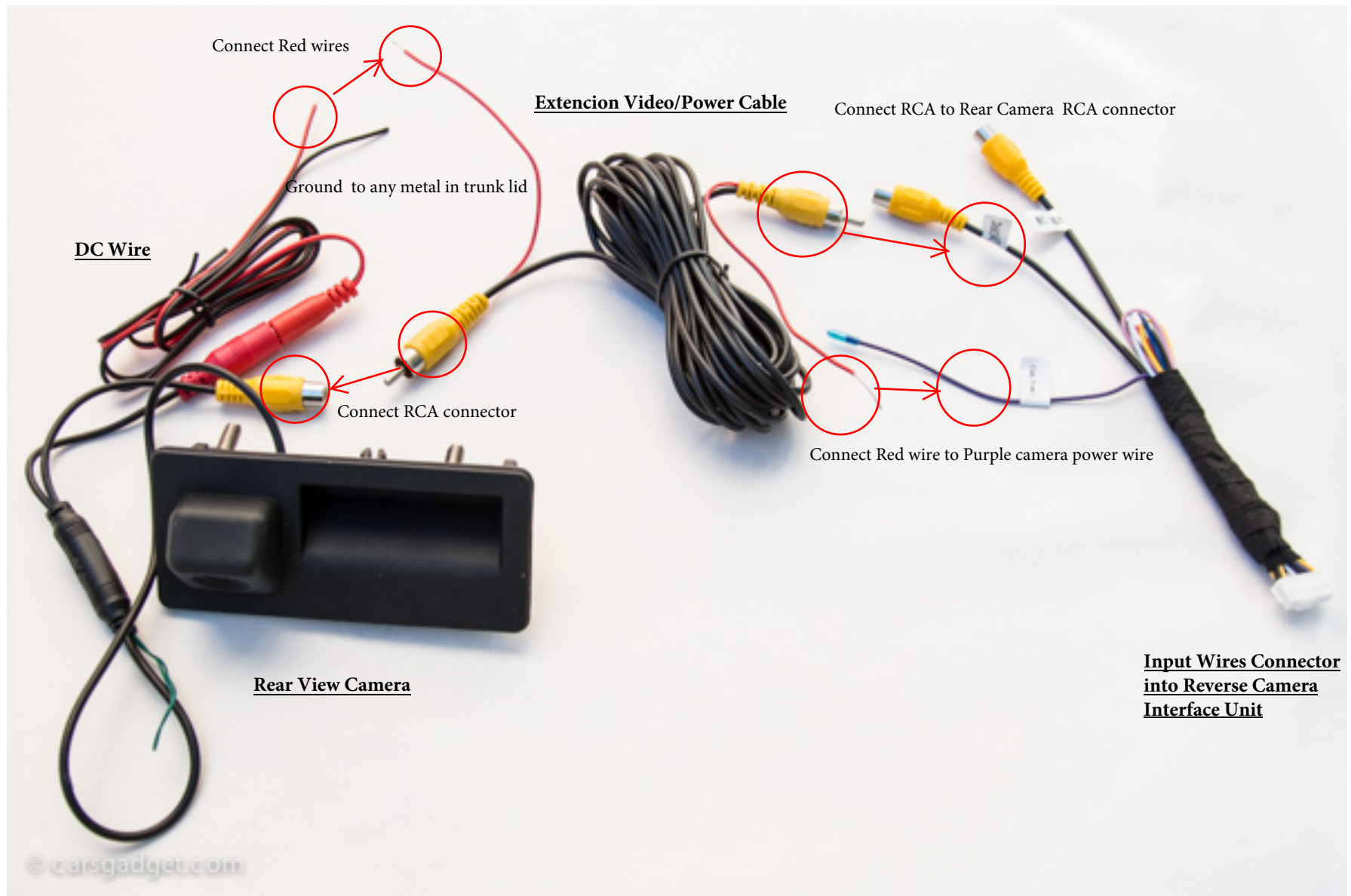

REMOVING MMI HEAD UNIT

This screenshot for references only.



AUDI MMI WIRING

Wiring diagram:

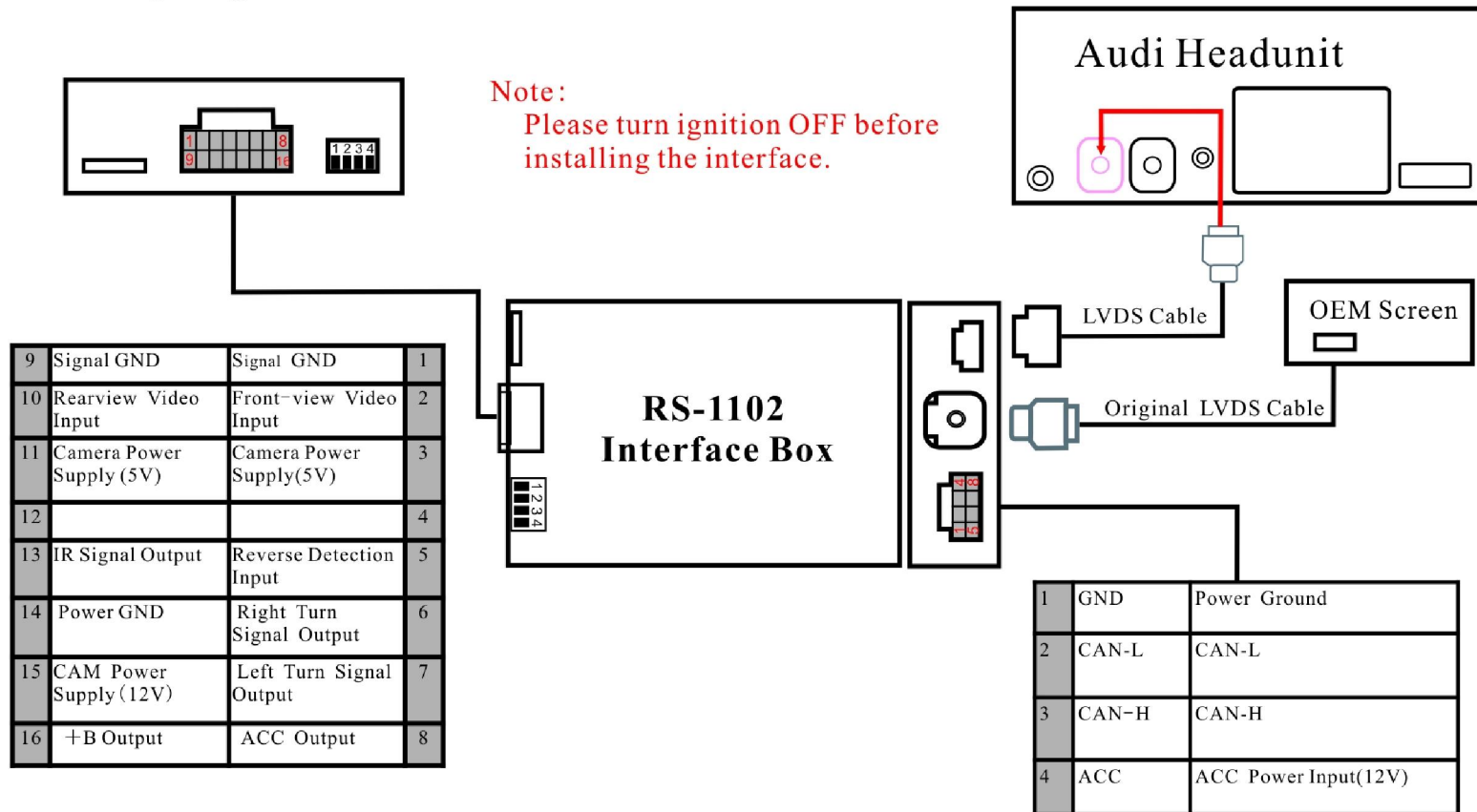

LVDS WIRING

MMI 3G Plus & 3G Head Unit

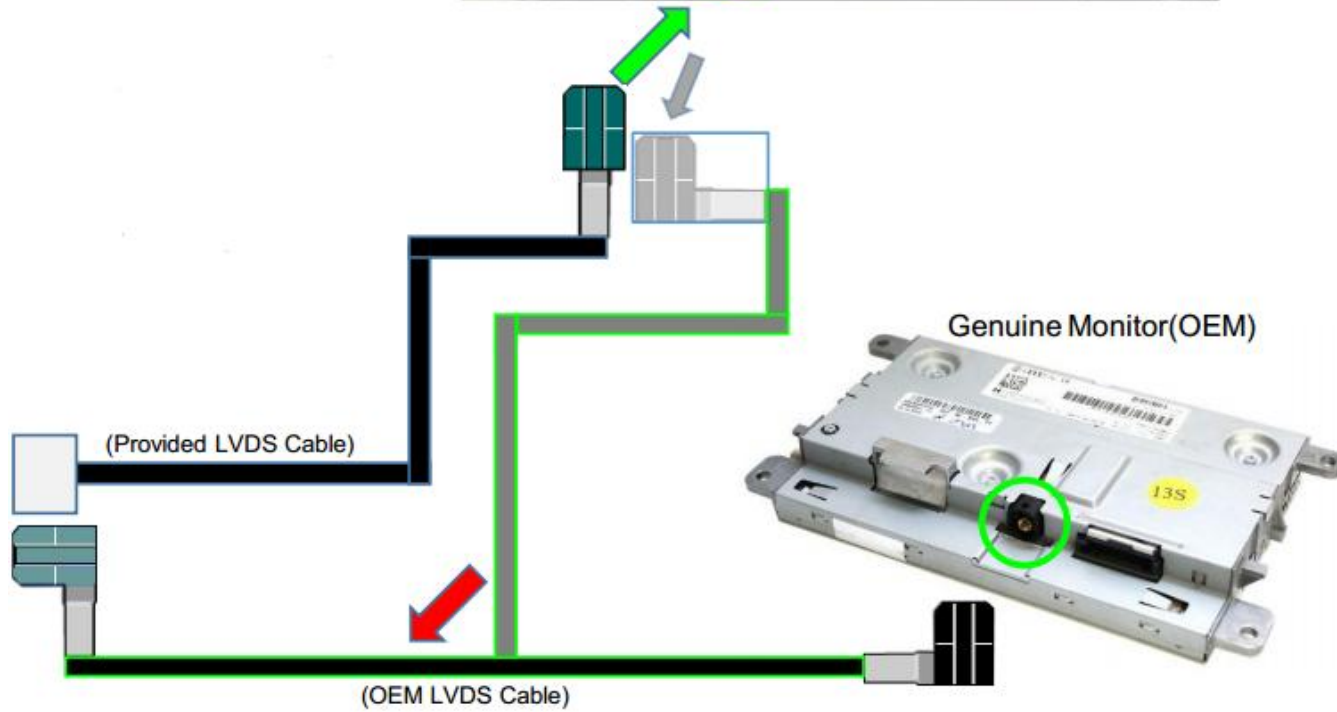

PROVIDED VLDS CABLE

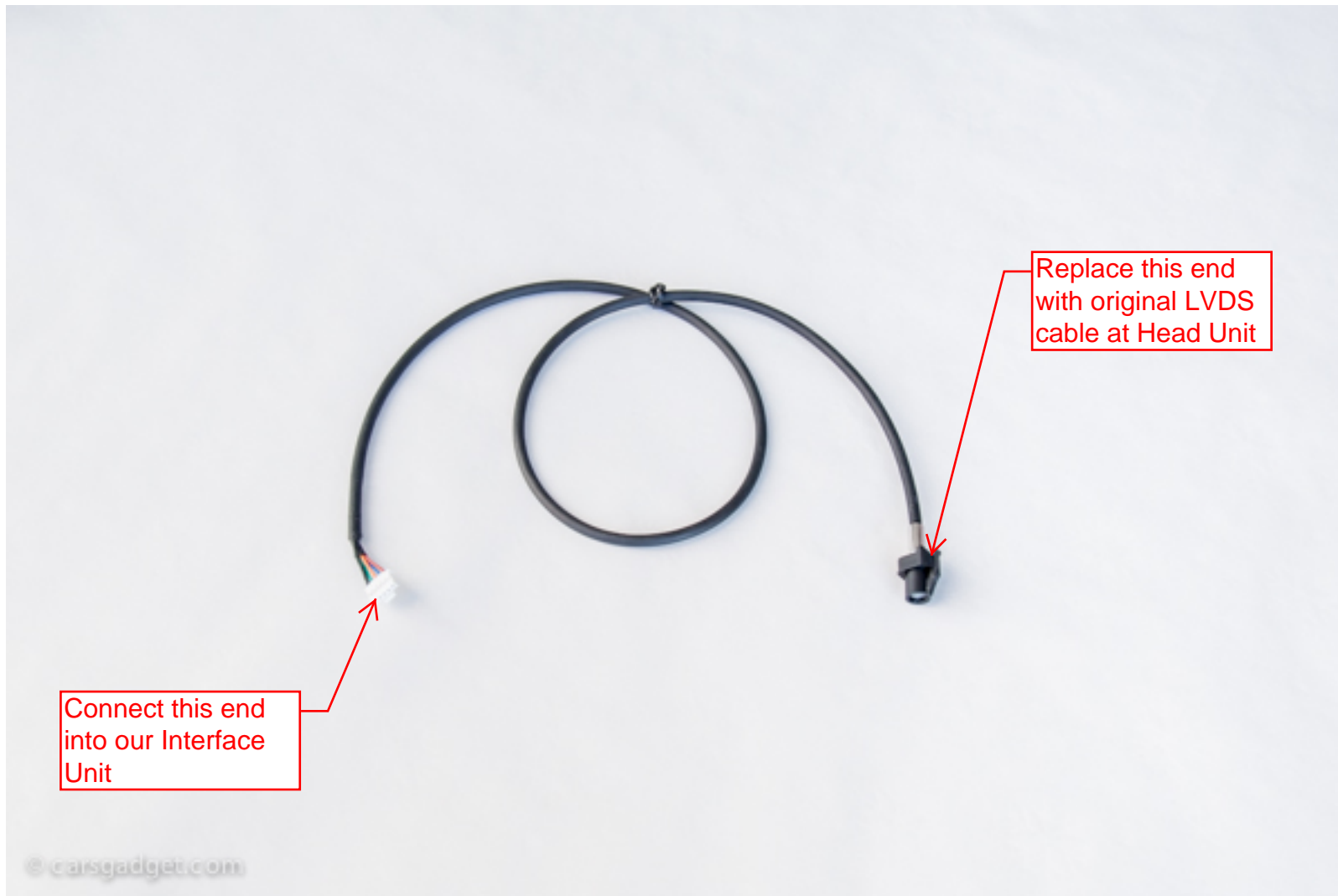

FUSE BOX, VIEW OF CAN H&L

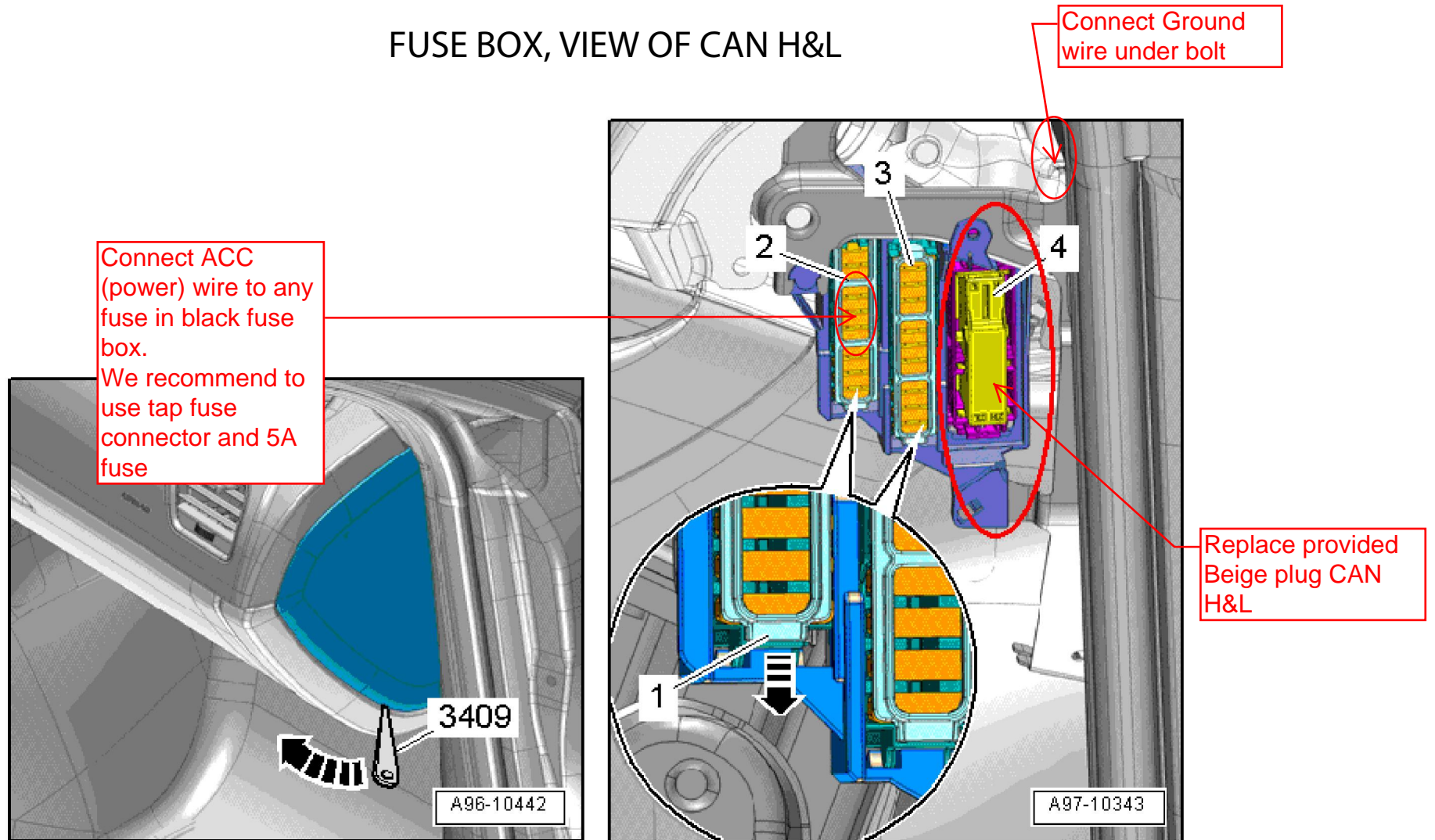

INPUT WIRES CONNECTOR

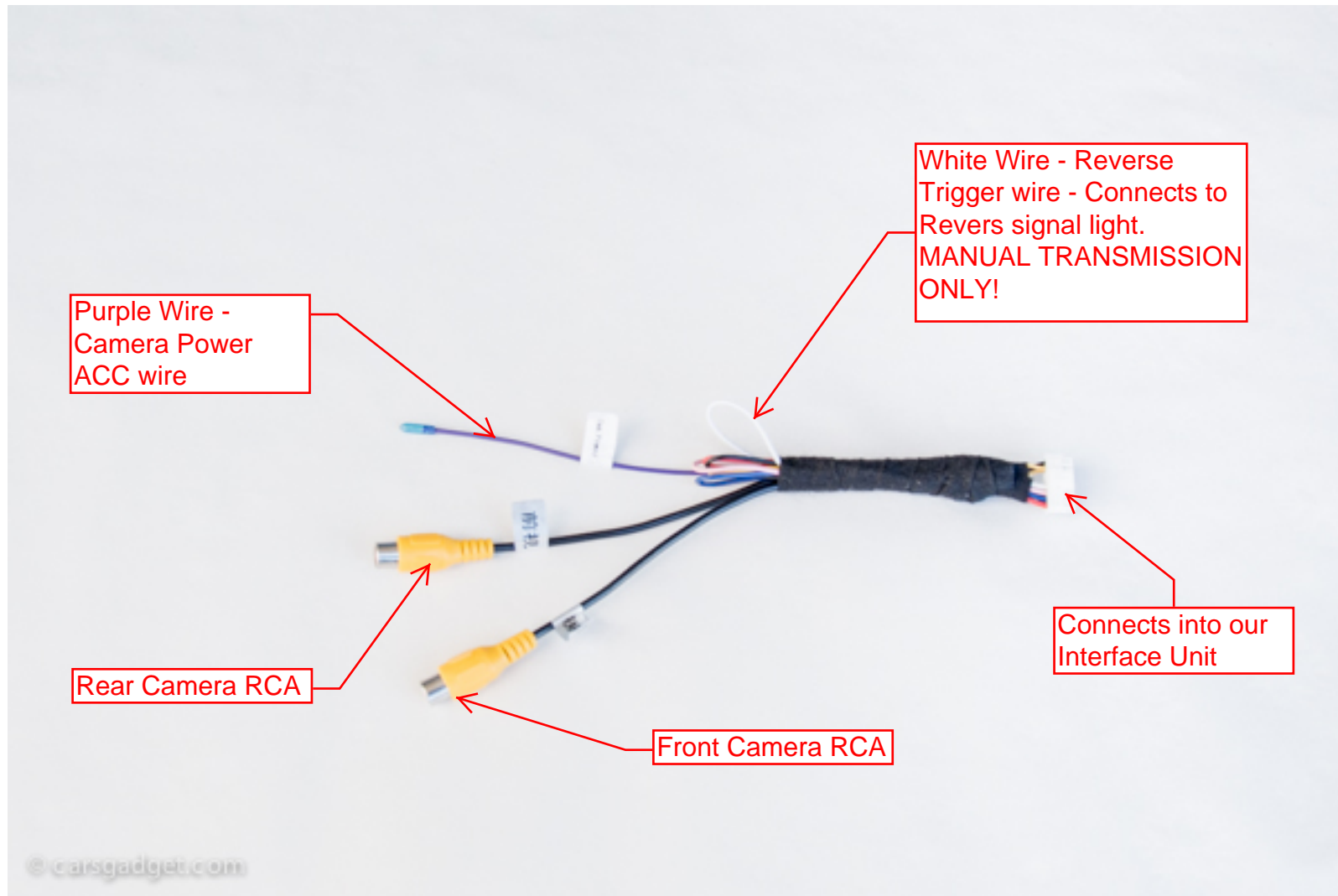

FOR MANUAL TRANSMISSION

REVERSE TAIL LIGHT WIRE LOCATION



1. Open carpet cover in the trunk - right side



2. Locate wire harness going to the right tail light .
3. Find Black/Grey wire.
4. Tap our provided wire to it.
5. Run this wire along with Camera Video/Power cable to the glove box and connect it with White wire at Reverse Interface Unit.

WE RECOMMEND TO USE THIS
ATC STANDARD TAP FUSE CONNECTOR AND 5A FUSE TO CONNECT ACC WIRE TO EXISTING 5A FUSE,
NOT PROVIDED. PICTURE JUST FOR REFERENCE ONLY

