

Removing and installing door trim (front)

Special tools and workshop equipment required

- ◆ Removal pliers -3392-

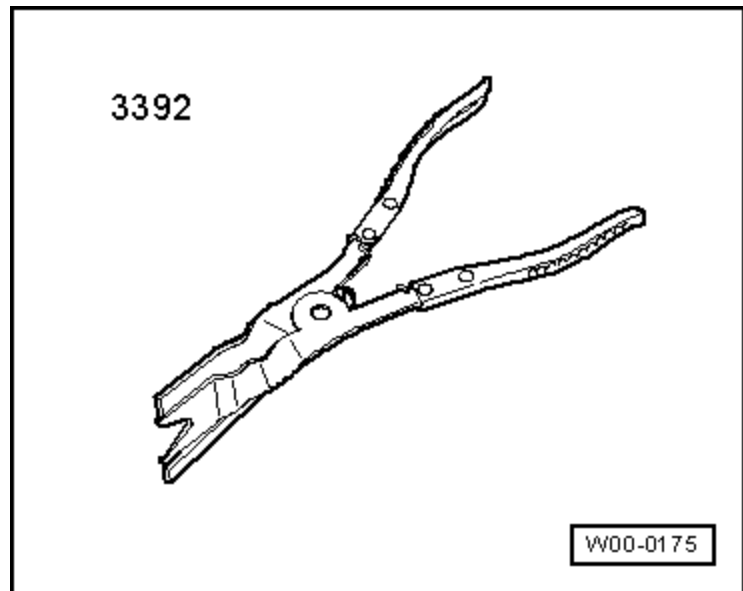

Removing

- Switch off ignition and remove ignition key.
- Remove trim panel → [Chapter](#).
- Remove bolts -1 ... 4-

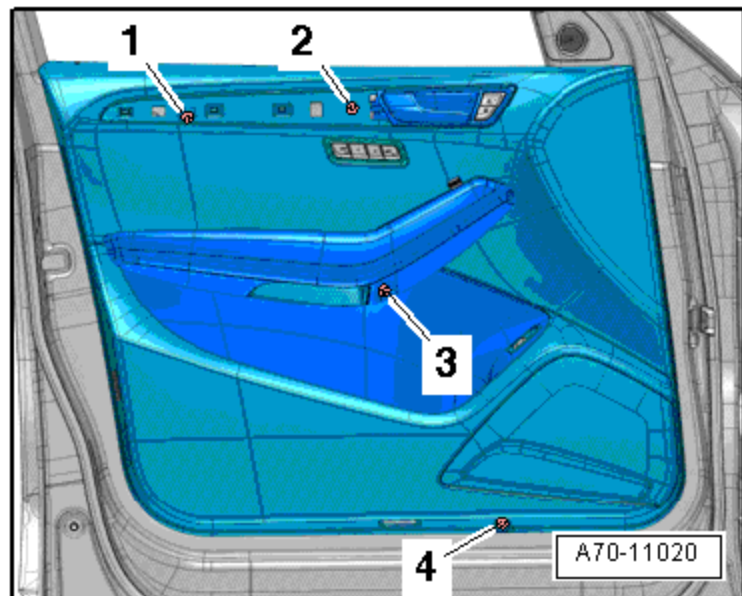

- Starting in bottom rear corner, use removal pliers -3392- to unclip door trim from door. To do so, insert removal pliers between door trim and door in area of retaining clips.

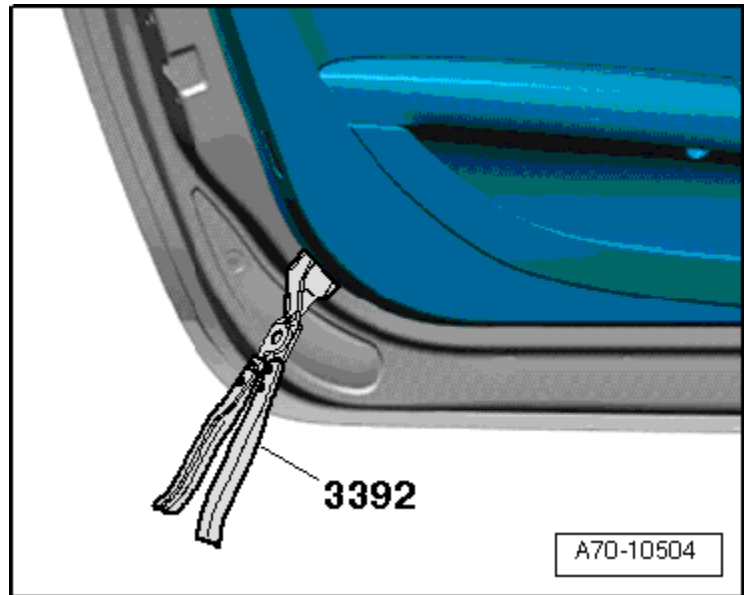

- Position of retaining clips -arrows-

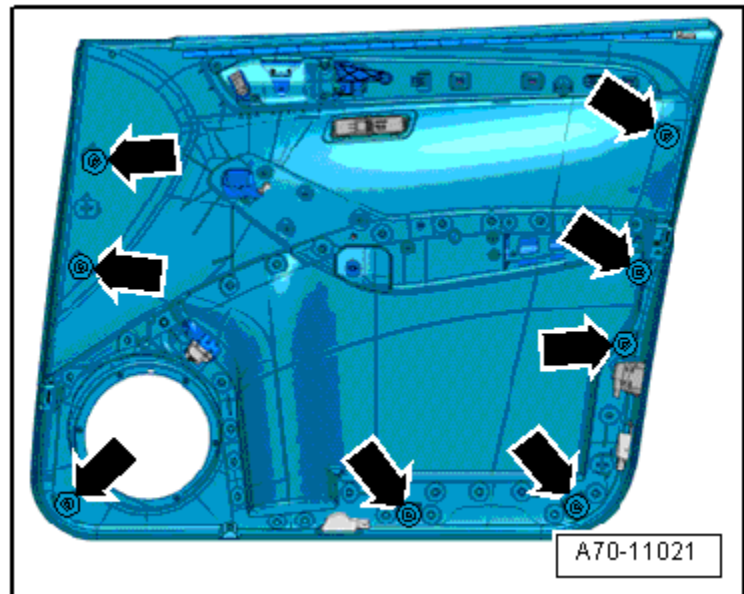

- Pull door trim -1- approx. 15 mm away from door all around -arrows A-
- Do not leave retaining clips in door.
- At location indicated, press door puller -2- with door trim upwards out of clip -3-- arrow B-
- Disengage door trim from door at top of window slot and detach.

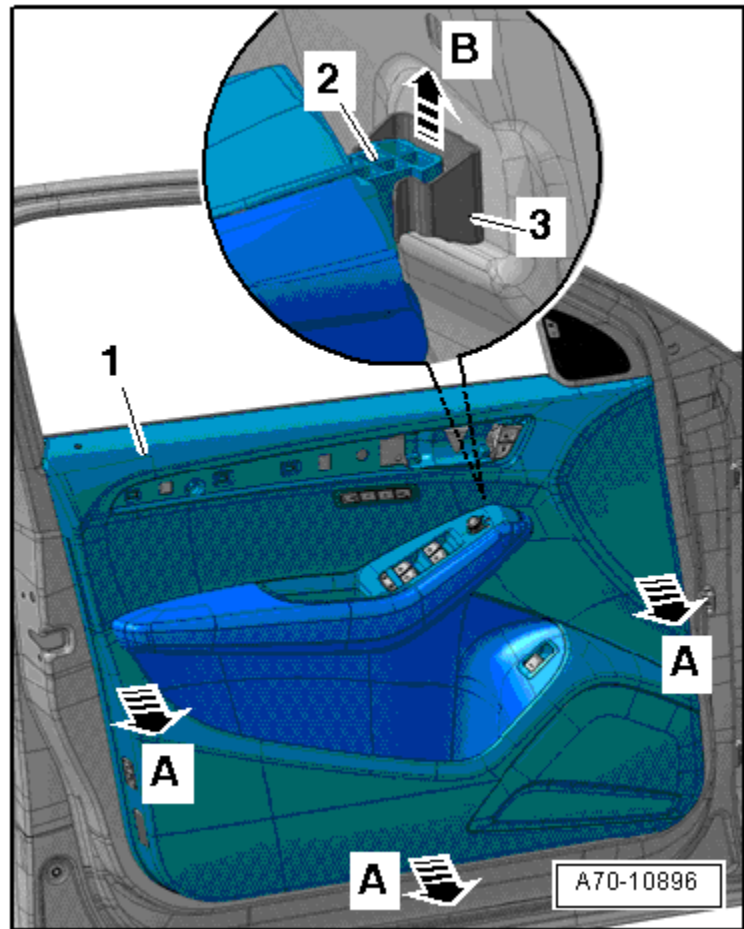

- Carefully disengage catch -4- at cable support bracket -2--arrow A-
- Pull Bowden cable -3- for interior door handle out of cable support bracket in direction of -arrow B-
- Disengage end of cable -1- at interior door handle.

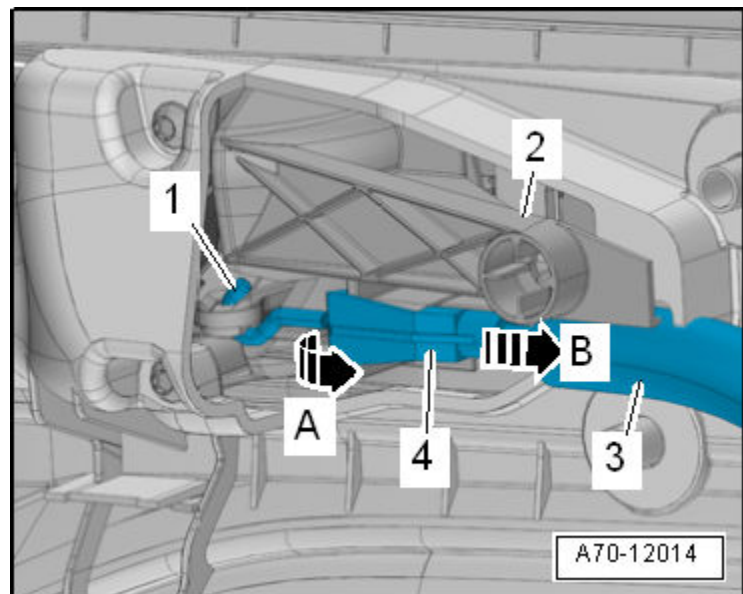

- To unplug electrical connector, press catch -1-, turn retaining bracket in direction of -arrow- and unplug connector.
- Detach door trim.

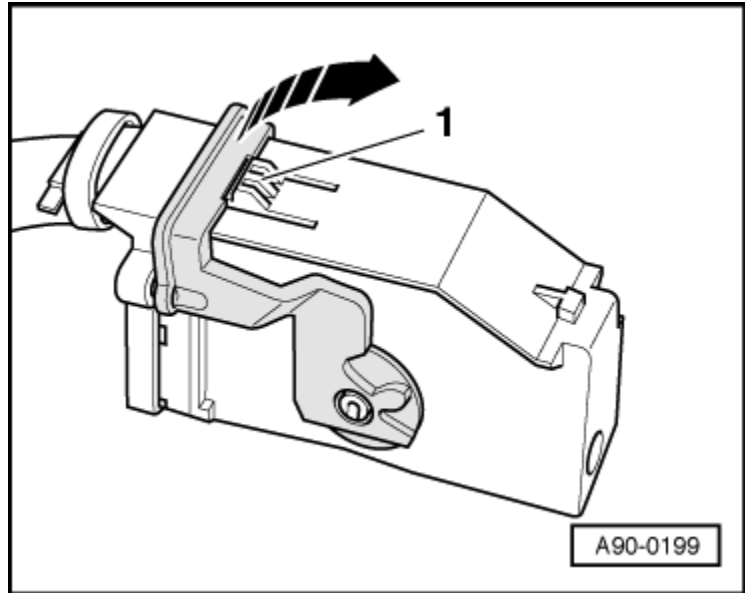

Installing

- Engage end of cable -1- in lever of interior door handle.
- Open side of eyelet at end of cable must face upwards.
- Pull Bowden cable -3- for interior door handle in direction of -arrow B- and insert it in cable support bracket -2-.
- Catch -4- must engage audibly in cable support bracket.

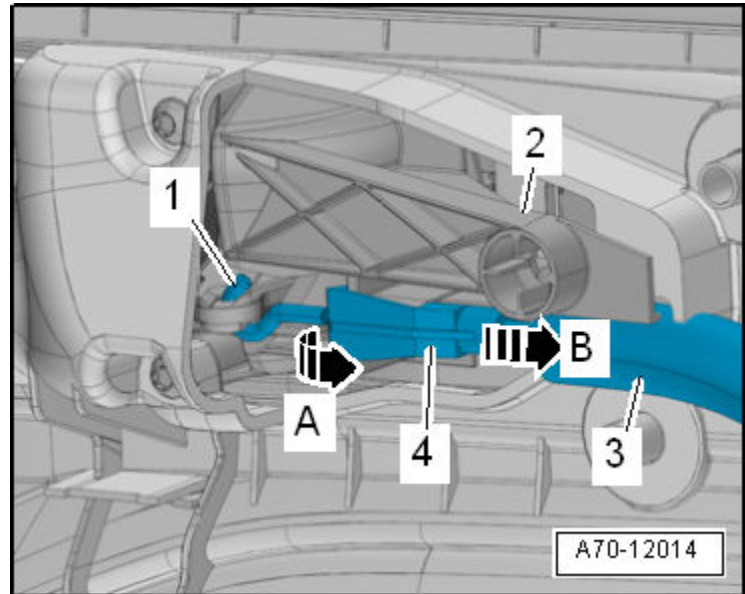



WARNING

- ◆ *Make sure that the door is properly sealed when it is installed; otherwise the crash sensor (pressure sensor) may not function correctly.*
- ◆ *The retaining clips -arrows- for the door trim provide a seal for the system. If necessary, renew retaining clips for door trim.*

- Plug in electrical connector at door control unit.

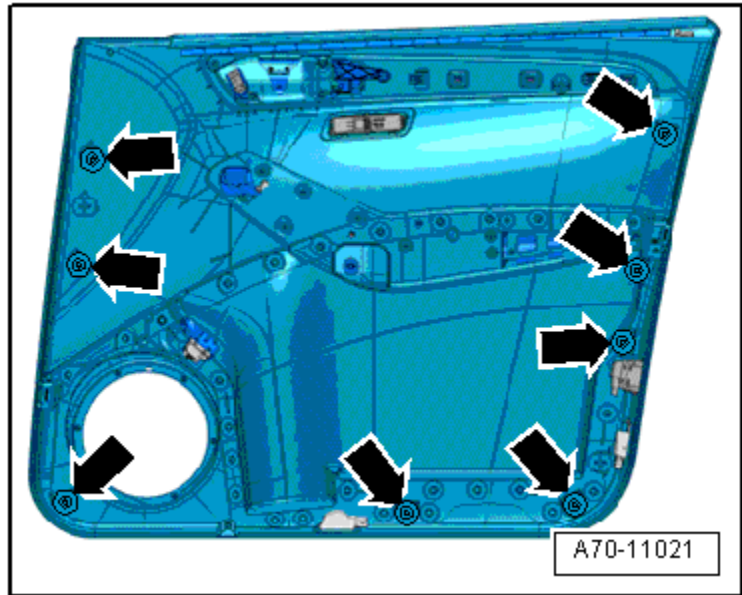

- Position door trim at window slot and press on downwards.
- Carefully position retaining clips for door trim on door and press door trim onto door until retaining clips engage audibly.
- Engage door puller -1- in clip -2- by pressing door puller onto door until it engages audibly.

Perform remaining installation in reverse order of removal.

Tightening torque → Chapter

