

Account

Vehicle

Help

Search

Contact

AutoZone Community

Exit

Your Vehicle: 2010 Audi Q7 Quattro (4LB) V6-3.0L DSL Turbo (CATA)



SAVE \$25  
instantly on 4 tires!

tirebuyer.com

SAVE NOW >

SAVE \$25  
instantly on 4 tires!

tirebuyer.com

SAVE NOW >

[Vehicle](#) » [Technical Service Bulletins](#) » [All Technical Service Bulletins](#) » [Body - Noises From The Sunroof Area](#) » [Service](#) » [Audi Q5/Audi Q7](#)

## Audi Q5/Audi Q7

### Audi Q5/Audi Q7:

1. Completely open the front sunroof panel.

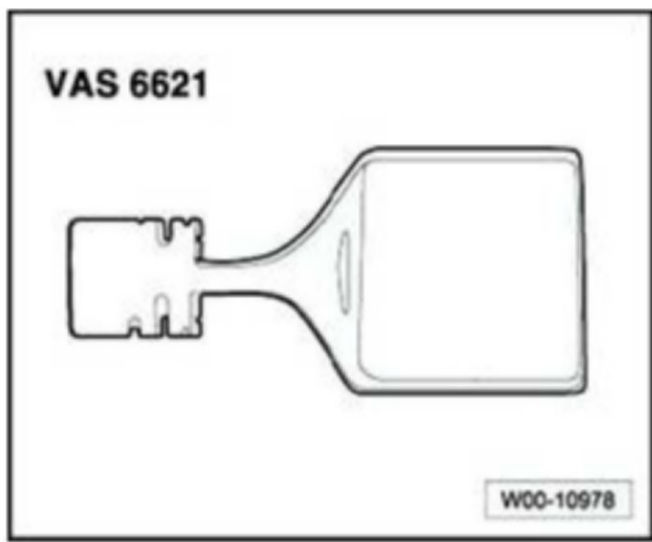

Figure 20. VAS 6621.

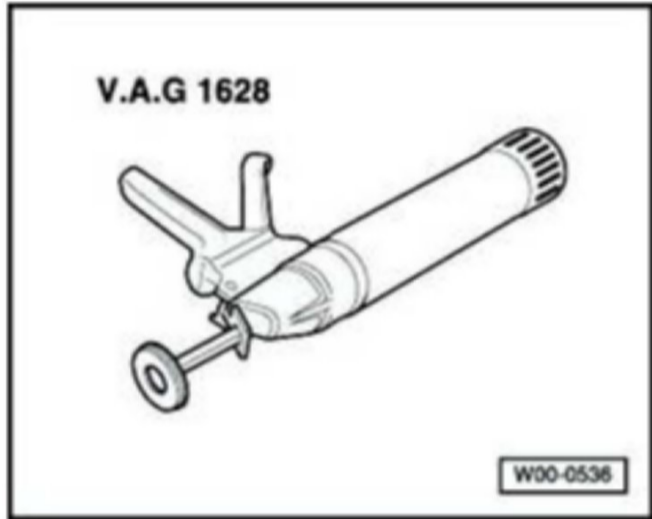

Figure 21. VAG 1628.

Zoom

Sized for Print

2. The cleaning and lubrication of the rails will be done with the VAS 6621 and the VAG 1628.

### Cleaning The Guide Rails

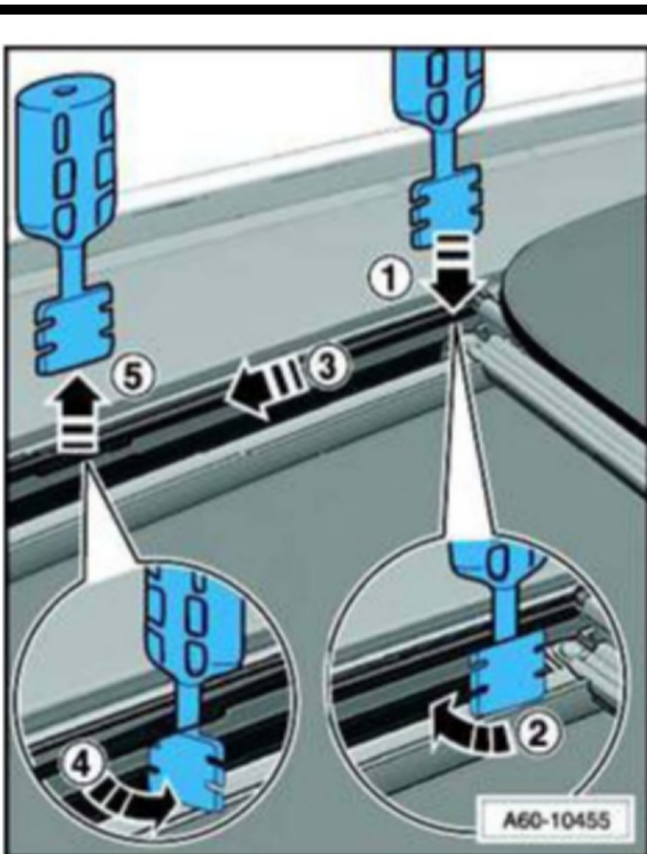

Figure 22. (1) Insert VAS 6621 in rear of guide rail. (2) Turn VAS 6621 90°. (3) Slide VAS 6621 towards front. (4) Turn 90°. (5) Removing VAS 6621.

1. The bulk of the old lubricant, dirt and debris will be removed as follows: Insert the VAS 6621 to the rear of the guide rail (Figure 22, 1), turn it 90°(Figure 22, 2) and slide it toward the front (Figure 22, 3). Turn the tool 90°once again and remove it (Figure 22, 4-5). Clean the old lubricant and debris from the tool. Repeat this procedure starting from the front of the guide rail and slide the tool toward the rear. Perform this procedure to both sides.
2. Remove any remaining old lubricant, dirt and debris using a lint-free cloth. Using a vacuum cleaner may aid in removing any sand, grit or other abrasive materials that would damage the sunroof mechanism.

### Lubrication of Guide Rails:

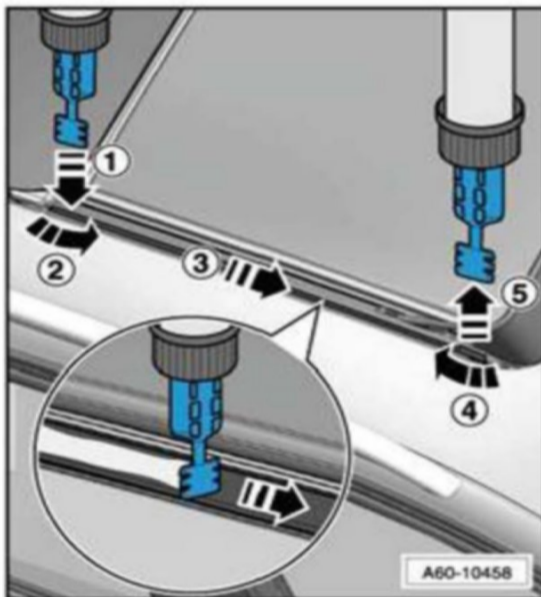
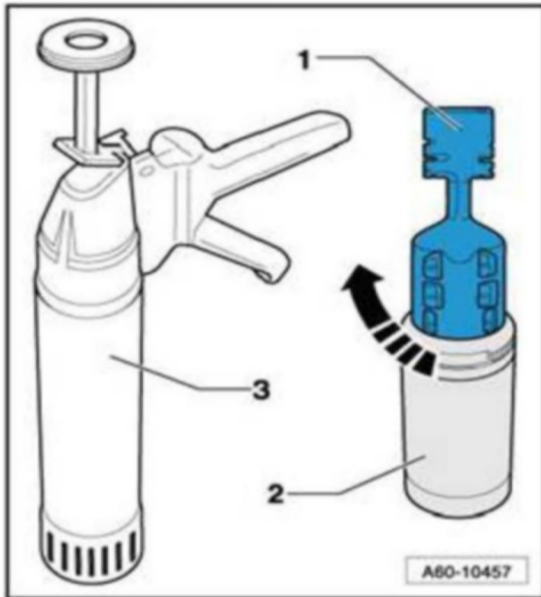
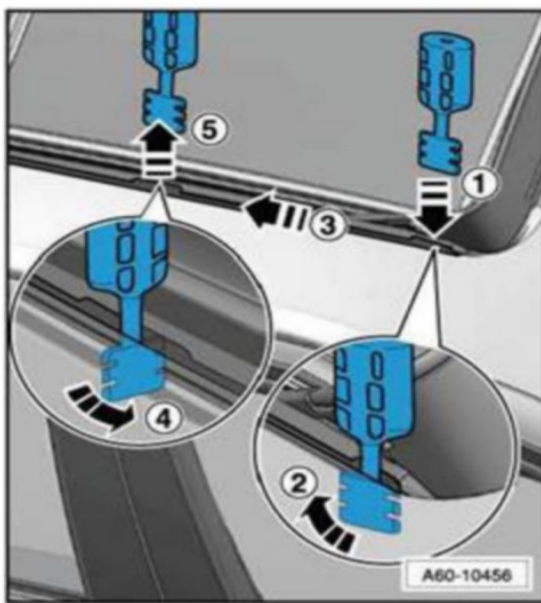

**Figure 23.** Lubricant and VAS 6621.



**Figure 24.** Lubricant with VAS 6621 installed.

1. Thread the VAS 6621 tool onto the lubricant canister (G 060 751 A2). Install the assembly into the VAG 1628.



**Figure 25.** Install VAS 6621 with canister.

Zoom

Sized for Print

2. Insert the VAS 6621 into the guide rails in the same way as the cleaning procedure and inject the lubricant evenly along the guide rails. Perform this along the entire length of the guide rails and to both sides.

### **Cleaning and Lubrication of the Lid Mechanism of the Front and Rear Lids:**

1. Move both the front and rear sunroof panels to the vent position. Remove the old lubricant, grit and debris using a lint-free cloth.

**Tip:** Cover the interior of the vehicle to protect against falling debris.

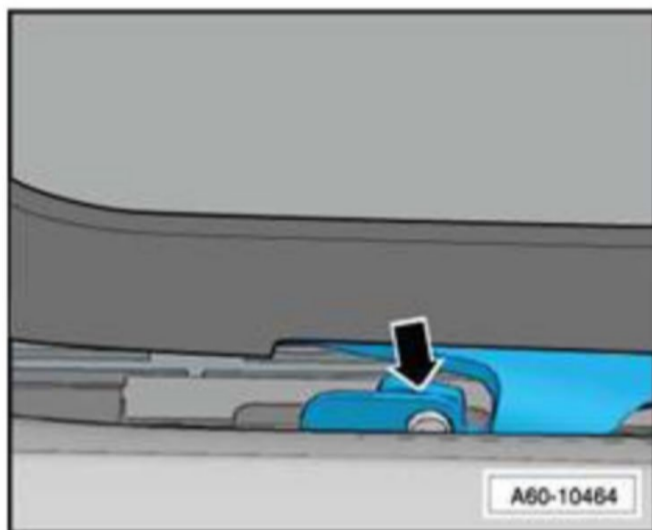
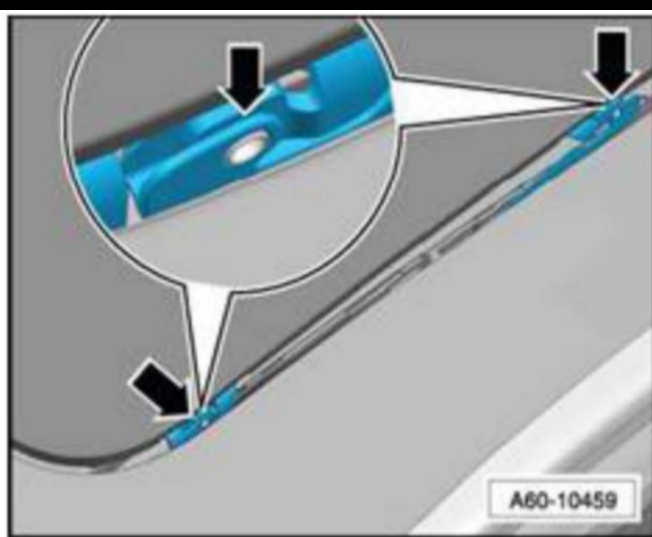

**Figure 26.** Location of guide plate rollers.

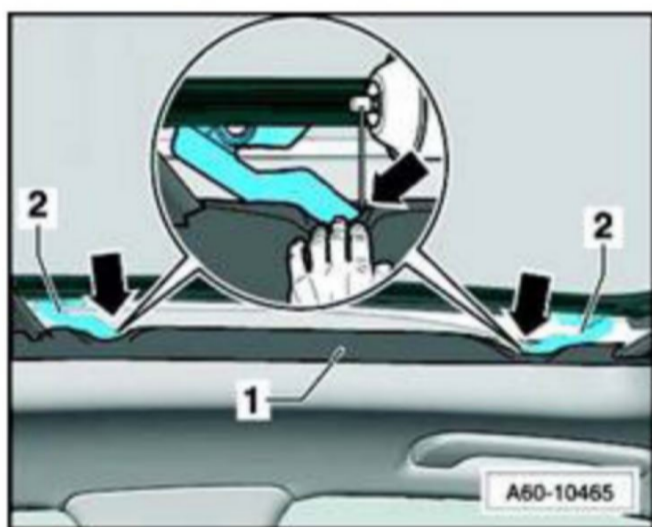
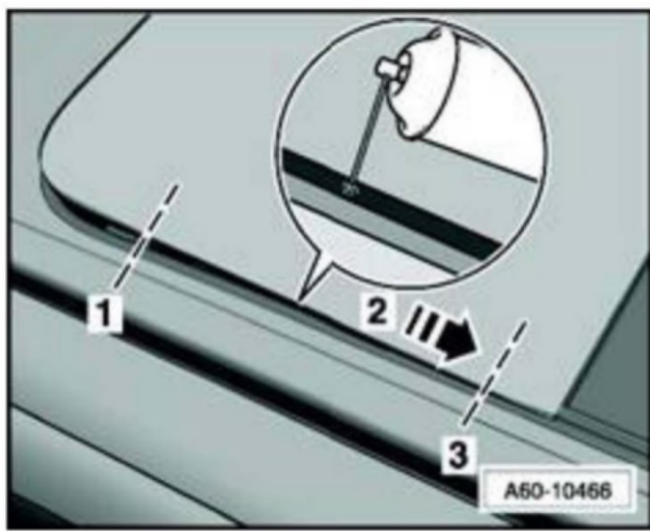

**Figure 27.** Exposing the guide plates.

Zoom

Sized for Print

2. Spray lubricating paste G 060 751 A3 on the mechanism for the front and rear sunroof panels at the areas indicated by the arrows in the illustration.
3. Clean and lubricate the guide plates of the front and rear sunroof panels. It will be necessary to press down on the lip of the rubber seal to expose the guide plates. Lubricate the guide plates with G 060 751 A3. Make sure the lubricant fully penetrates the rollers.



**Figure 28.** Lubricating guide plate on Audi Q7.

Zoom

Sized for Print

4. Spray lubricant G 060 751 A3 along the mechanism of the rear sunroof panel (Audi Q7) as shown in Figure 28.

#### **Cleaning and lubrication of the slides of the front sunroof panel:**

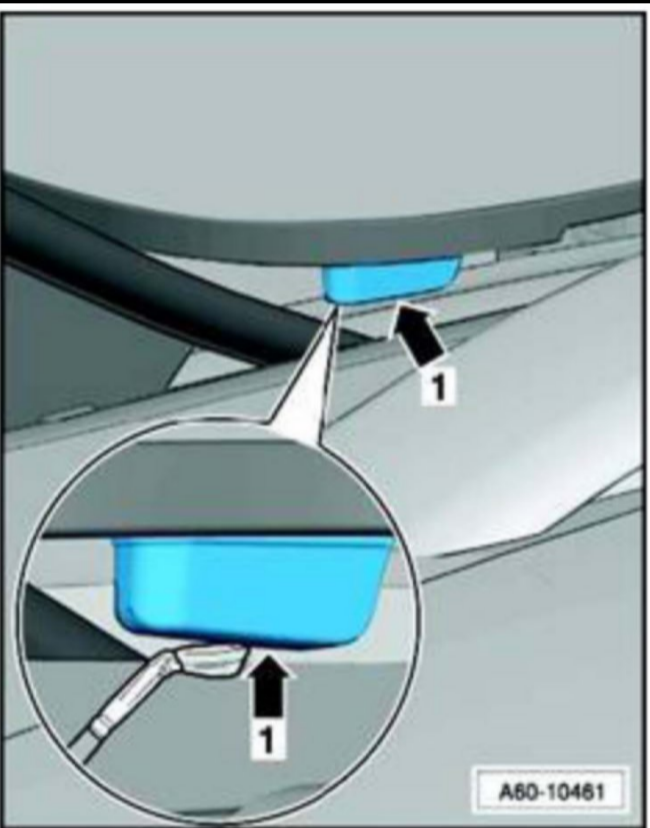

**Figure 29.** Cleaning and lubricating slides.

Zoom

Sized for Print

1. Clean the slides with a lint-free cloth. Apply lubricant G 060 751 A2 to the slides with a brush to both slides.

#### **Cleaning and lubrication of the seals:**

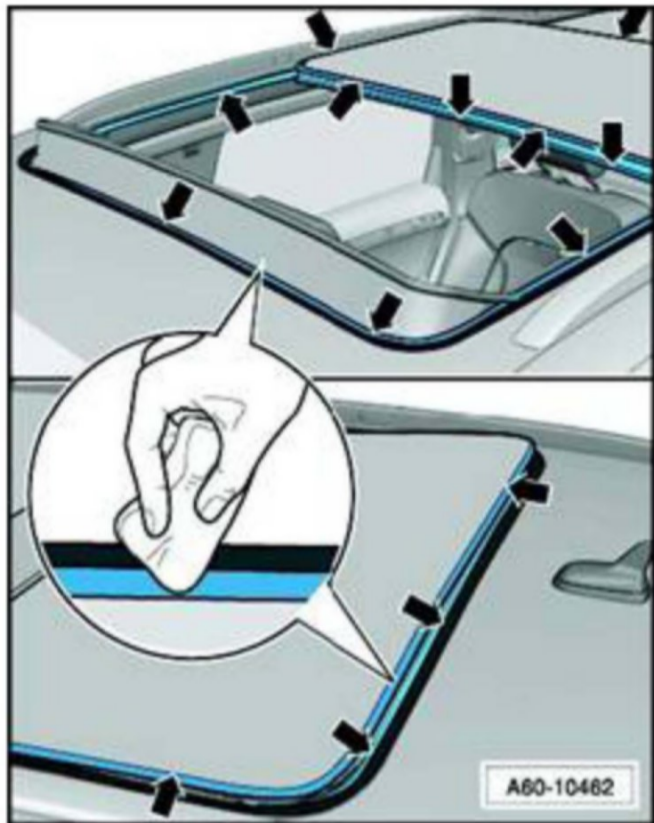

**Figure 30.** Cleaning the seals.

Zoom

Sized for Print

1. Clean all the seals with all-purpose cleaner D 009 401 04 and a lint-free cloth.



**Figure 31.** Perimeter seal.

Zoom

Sized for Print

2. Lubricate all the seals with special lubricating paste G 052 141 A2 using a brush.

**Tip:** No parts have to be removed. It is only necessary to completely open the sunroof panel.



**Figure 32.** Audi Q7 seal for cover 3.

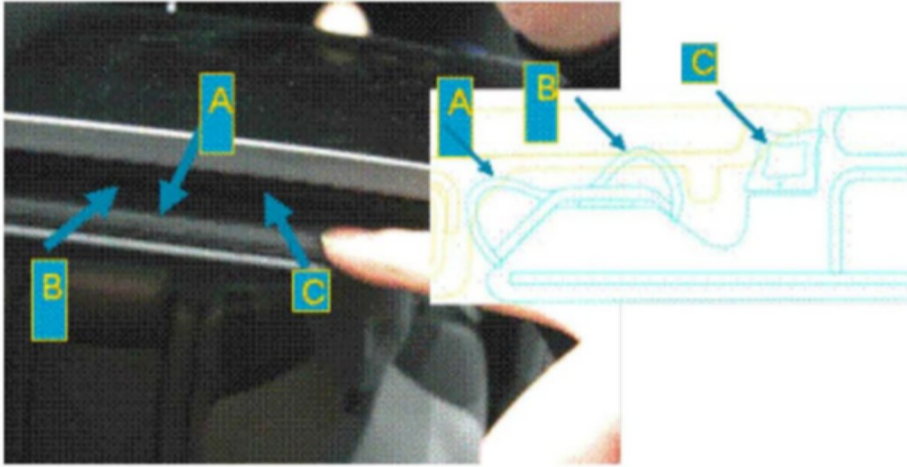
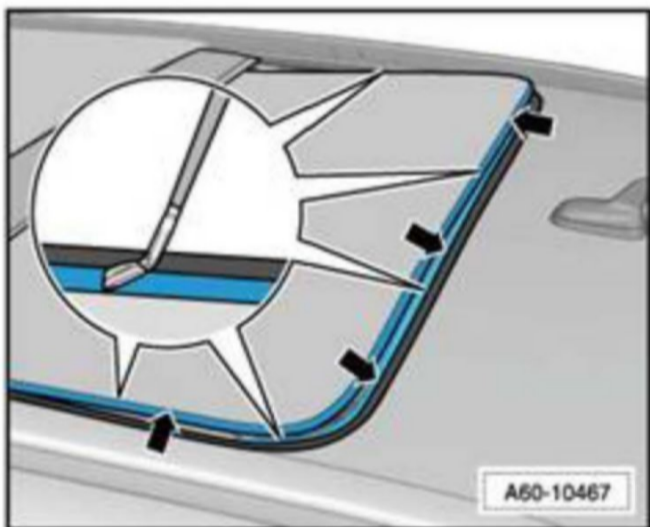

**Figure 33.** Audi Q7 front and rear cross seals of cover 2.

Zoom

Sized for Print



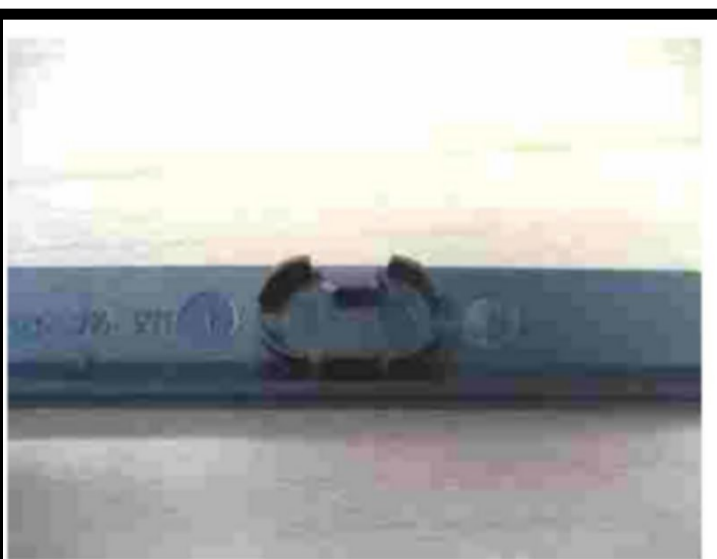

**Figure 34.** Lubrication of the seals.

Zoom

Sized for Print

3. Another source of noise can come from the sunroof panel trim. Make certain that all of the sunroof trim is intact and correctly installed.



**Figure 35.** Broken sunroof trim.

Zoom

Sized for Print



**Figure 36.** *Intact sunroof trim.*

Zoom

Sized for Print

4. Incorrectly installed, or incorrectly adjusted sunroof panels, cause tension and are another source of noise. Check and adjust as necessary using ElsaWeb or refer to TSB 2018898.
5. A loose wind deflector mounting can be a source of noise as well. Refer to TSB 2012804.

[Account](#) | [Vehicle](#) | [Help](#) | [Contact](#) | [AutoZone Community](#) | [Exit](#)

© 2016 ALLDATA, LLC. All Rights Reserved. [Trademarks](#) | [Privacy Policy](#) | [Terms and Conditions](#)