

Account

Vehicle

Help

Search

Contact

AutoZone Community

Exit

Your Vehicle: 2010 Audi Q7 Quattro (4LB) V6-3.0L DSL Turbo (CATA)



SAVE \$25
instantly on 4 tires!

tirebuyer.com

SAVE NOW >

SAVE \$25
instantly on 4 tires!

tirebuyer.com

SAVE NOW >

[Vehicle](#) » [Windows and Glass](#) » [Front Door Window Motor](#) » [Service and Repair](#)

Service and Repair

Window Regulator Motor

Removing

- Door trim removed..
- ⌘ The power window motor can be removed or installed with the motor or side window in any position.
- ⌘ Before removing motor, disconnect electrical harness connectors.
- Remove Torx(R) screws - 2 - (T30) and remove motor - 1 -.

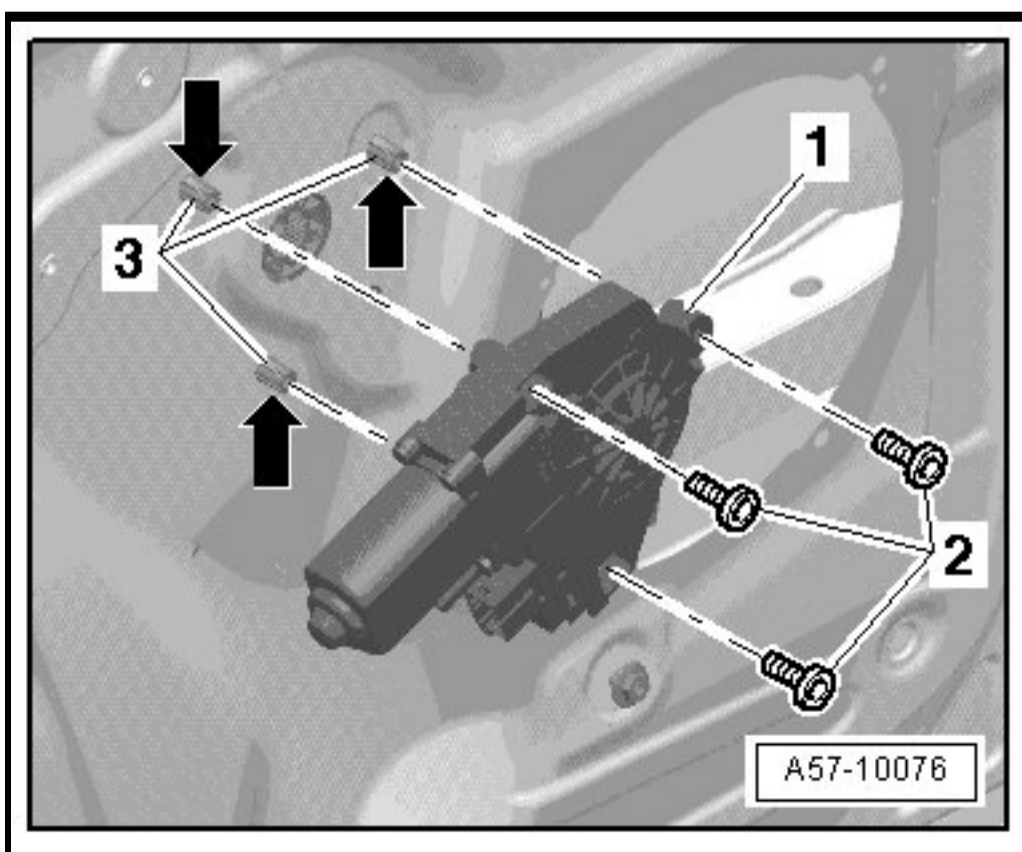

Installing

- When installing, make sure that threaded pins - **arrows** - engage in inner door plate.
- Slide window regulator motor - **1** - onto threaded pin - **3** - and secure with screws - **2** -.
- Tightening specification 3.5 Nm

- ⌘ Only switch ignition on after installing motor and connecting wires.
- ⌘ Then move door window upward to stop and keep pressing switch for window regulator for approximately 2 seconds longer.
- ⌘ This position is the base position and the high- and low-running function is activated.

[Account](#) | [Vehicle](#) | [Help](#) | [Contact](#) | [AutoZone Community](#) | [Exit](#)