

Your Vehicle: 2010 Audi Q7 Quattro (4LB) V6-3.0L DSL Turbo (CATA)



**SAVE \$25**  
instantly on 4 tires!



[Vehicle](#) » [Brakes and Traction Control](#) » [Disc Brake System](#) » [Brake Caliper](#) » [Service and Repair](#) » [Overhaul](#) » [Rear Brake Caliper Piston](#)

## Rear Brake Caliper Piston

### Rear Brake Caliper Piston

#### Special tools, testers and auxiliary items required

- ✘ Trim Removal Wedge (3409)
- ✘ Piston resetting tool (T10145)

#### Removing

- Force piston from brake caliper housing, one at a time, using compressed air.

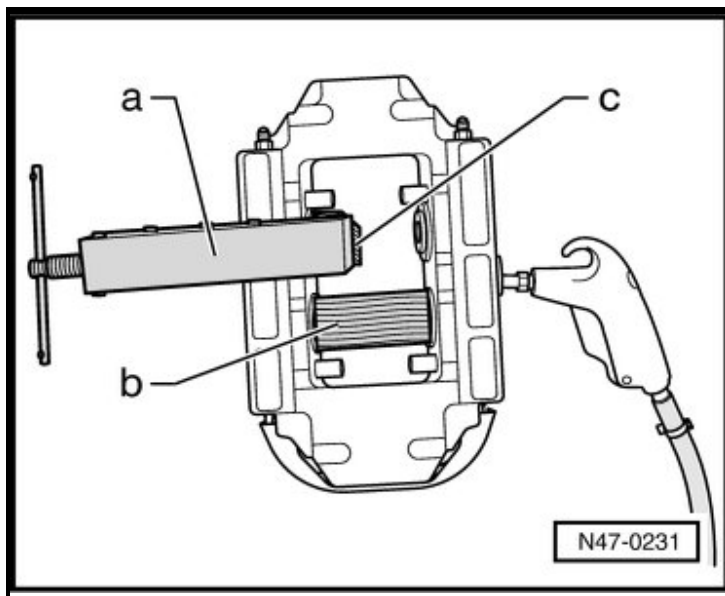

- ⊠ Only one piston can be pressed out at a time. Secure opposite piston in brake caliper housing using piston resetting tool - **a** -. Block the other pistons, e.g. using wood blocks - **b** -. In addition, place a wooden board - **c** - in front of the piston resetting tool so that the piston will not be damaged when pressed out.

- Remove seal with (3409).

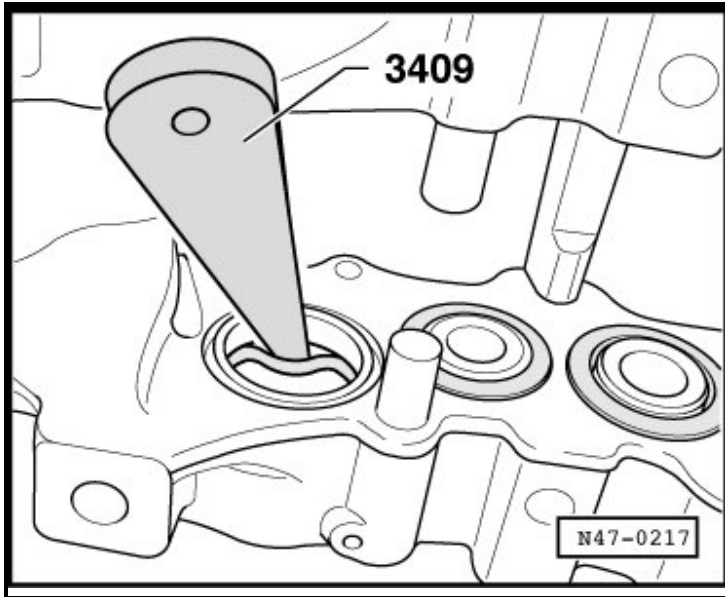

- ⊠ When removing, make sure that surface of cylinder is not damaged.

#### Installing

- The surface of the piston and seal must only be cleaned with mineral spirits and then dried.
- Thinly coat piston and seal with assembly paste (G 052 150 A2) before inserting.
- Insert oil seal in brake caliper housing.

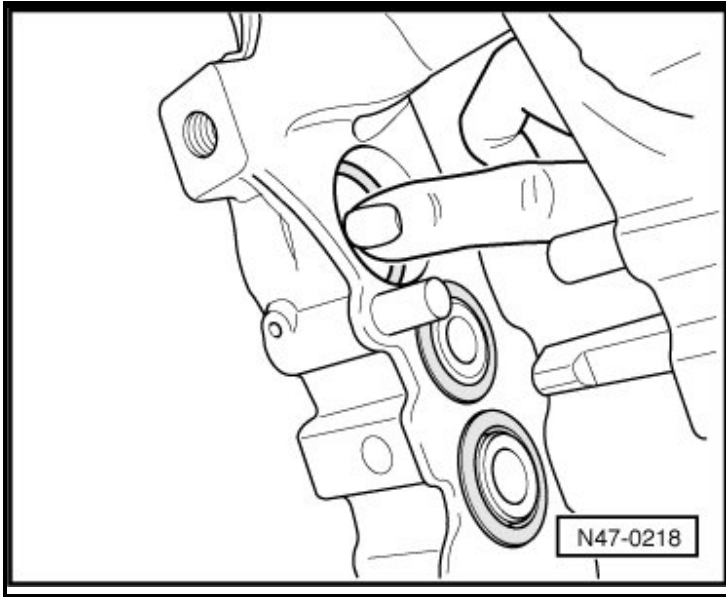

- Install protective cap on piston.

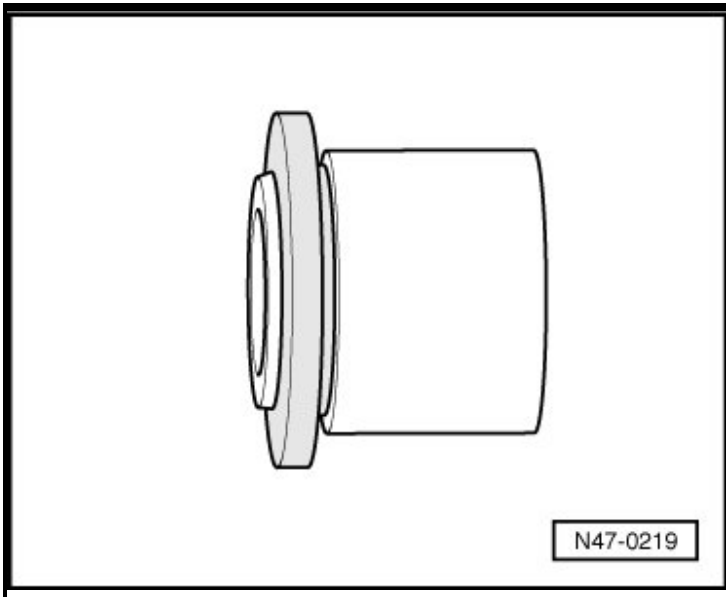

- Push piston into brake caliper housing using constant pressure.

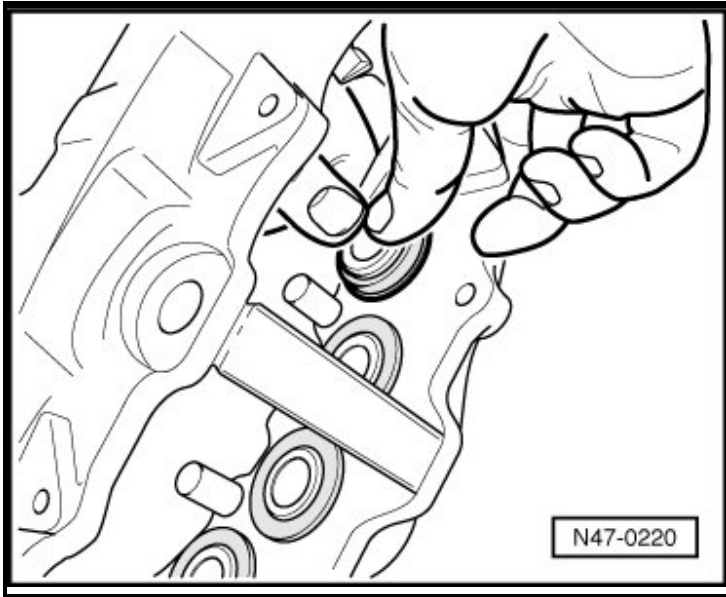

- ⌘ The protective cap must be seated properly in the groove, push slightly farther if necessary.

[Account](#) | [Vehicle](#) | [Help](#) | [Contact](#) | [AutoZone Community](#) | [Exit](#)

© 2017 ALLDATA, LLC. All Rights Reserved. [Trademarks](#) | [Privacy Policy](#) | [Terms and Conditions](#)