



Audi Q7 - Power Transmission / Transfer Case 0AQ

Self-Study Programme 363

Audi Q7 - Power transmission by the inventor of the quattro®.

The powertrain concept of the Audi Q7 offers impressive performance at high speeds in addition to outstanding dynamics, both on and off the road.

The permanent quattro four-wheel drive® with asymmetric, dynamic torque split ensures maximum traction and cornering stability. These features are essential to good driving dynamics and active motoring safety, particularly when driving on paved roads and at high speeds.

The newly developed transfer case 0AQ is the centrepiece of the power transmission system.

This SSP deals mainly with the design and function of this new development.



Contents

Introduction

Drive concept	4
Subassemblies overview	6

Brief description of the gearbox

6-speed manual gearbox 08D	8
6-speed automatic gearbox 0AT / 09D	9

Gear selector mechanism

Automatic gearbox selector mechanism	11
Manual gearbox selector mechanism (refer to SSP 299)	

Transfer case 0AQ

Design / function of transfer case 0AQ	16
Self-locking centre differential	18
Components overview / design / function	19
Asymmetric basic torque distribution	21
Asymmetric/dynamic torque distribution	22
Chain drive	26
Lubrication	28
Oil supply / sealing	30

Service

Service / special tools	31
-----------------------------------	----

Useful information

Operating instructions	32
----------------------------------	----

This self-study programme teaches the design and function of new vehicle models, new automotive components or new technologies.

**The self-study programme is not a workshop manual!
All values given are intended as a guideline only, and refer
to the software version valid at the time of publication of the SSP.**

Please refer to the relevant service literature for current inspection, adjustment and repair instructions.

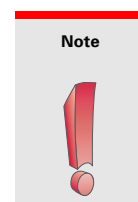
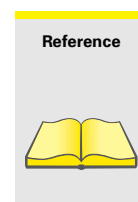

Introduction

Drive concept

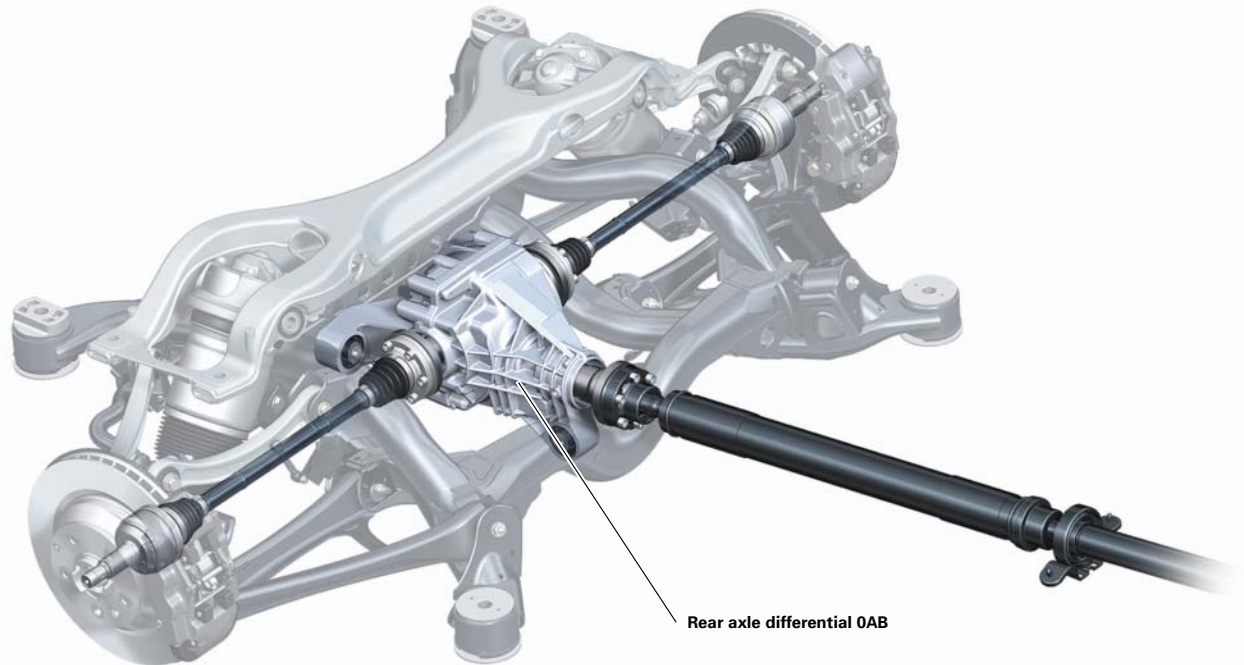

363_002

As an SUV* with excellent on- and off-road driving dynamics, the Q7 is equipped as standard with quattro four-wheel drive.

The running gear and the layout of the drive train sub-assemblies were adopted from the VW Touareg.

This configuration allows the engine to be positioned directly over the front axle. Thus, the step-up gear and the transfer case migrate more towards the centre of the vehicle, favouring a well-balanced axle load distribution beneficial to driving dynamics.

The sub-assemblies step-up gear, front axle differential and transfer case are independent components. The powertrain has what is known as a "modular design".

The advantage of this modular design is that it enables the ground clearance of an off-road vehicle to be increased.

* SUV = sport utility vehicle

One of the primary development goals for the Audi Q7 was good driving dynamics on paved roads. A special reduction gear and a mechanical differential lock were dispensed with in favour of the redesigned transfer case and the newly developed self-locking centre differential.

The self-locking centre differential is already in use in the Audi RS4 and S4, and features asymmetric/dynamic torque distribution.

Up to 85% of driving torque can be transferred mechanically, i.e. without EDL engagement, to the rear axle and up to 65% to the front axle. The new differential ensures optimal on-road driving dynamics.

When wheelspin occurs - off road or on icy surfaces - the EDL control system engages and provides traction in almost any driving situation.

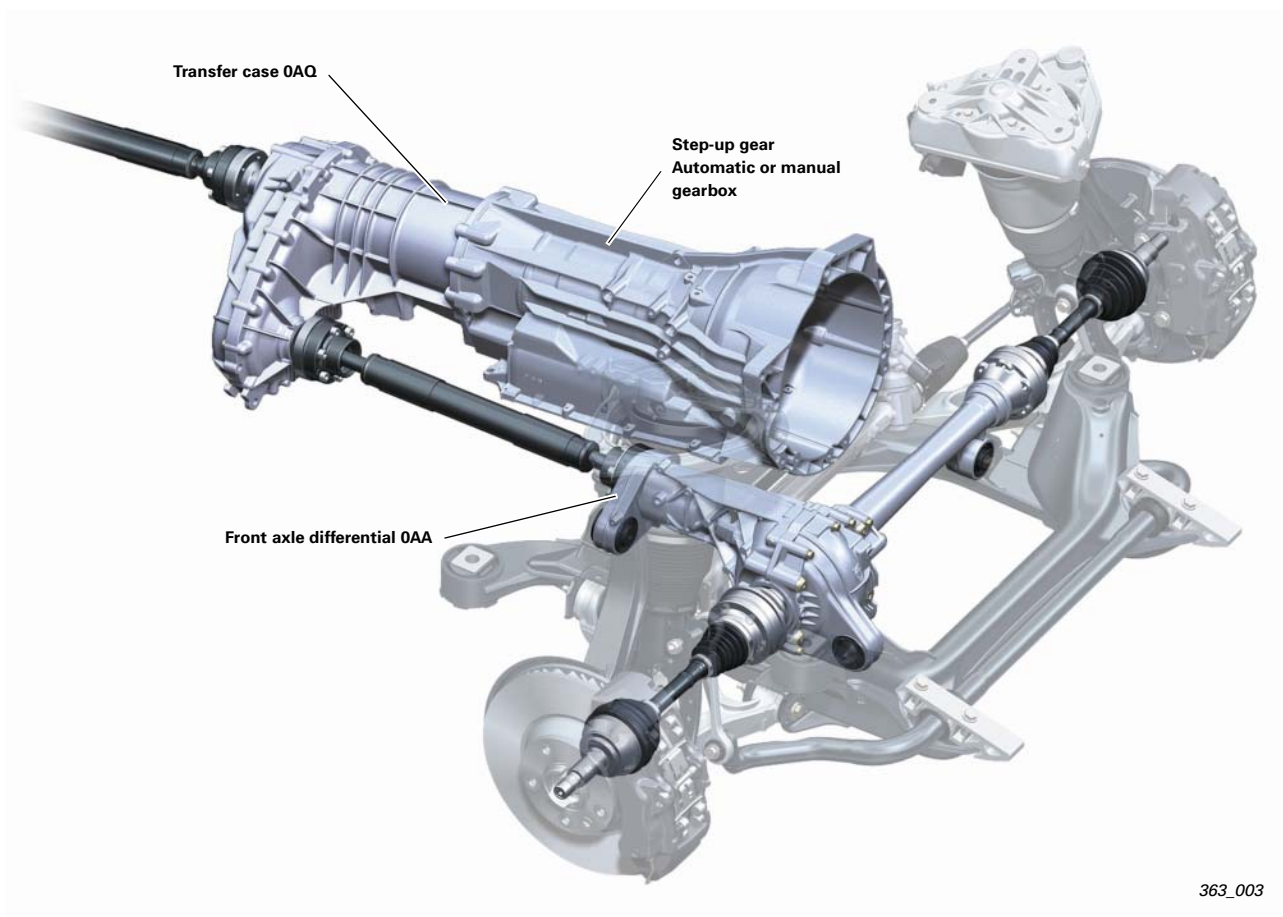

Introduction

Sub-assemblies overview

The following gearboxes are used:

Audi Q7 4.2 FSI:
257 kW (350 bhp), 440 Nm

Audi Q7 3.0 TDI:
171 kW (233 bhp), 500 Nm

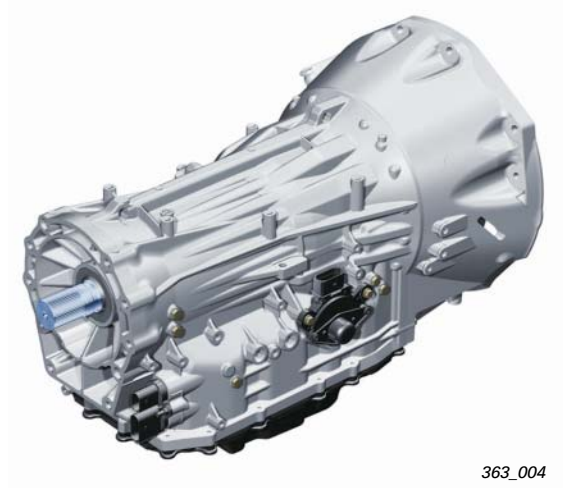

363_004

6-speed automatic gearbox 09D

Audi Q7 3.6 FSI:
206 kW (280 bhp), 360 Nm

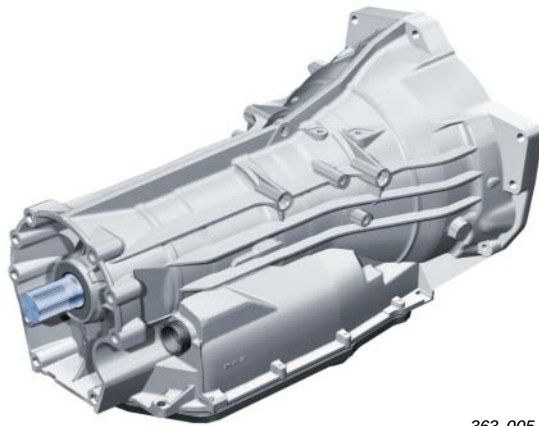

363_005

6-speed automatic gearbox 0AT
(expected SOP: 4th quarter 2006)



363_006

6-speed manual gearbox 08D/ ML400
(expected SOP: 2nd quarter 2006)

The front and rear axle differentials derive from the VW Touareg. Both differentials are manufactured by ZF Getriebe GmbH.

Front axle differential 0AA

The left-hand drive flange shaft has been extended to compensate for the asymmetric installed position of the front axle differential.

Thus, the additional torque resultant from the drive torque is transmitted symmetrically to the front axle. Negative effects on steering are thus eliminated.

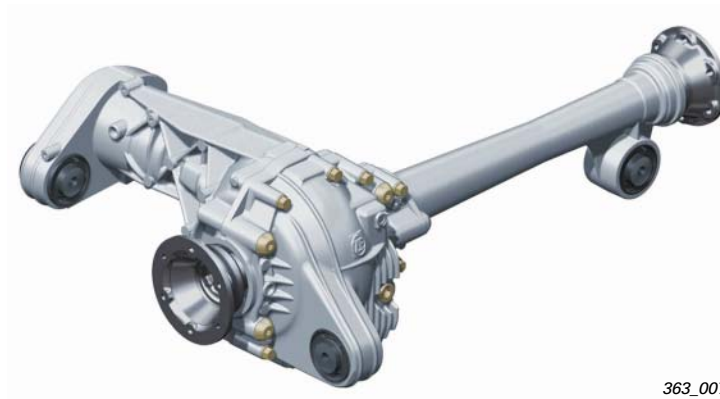

363_007



363_008

Rear axle differential 0AB



363_009

Transfer case 0AQ was redesigned for use in the Audi Q7. The 0AQ transfer case was developed in conjunction with, and is manufactured by Borgwarner.

Brief description of the gearbox

6-speed manual gearbox 08D...

... is a conventional full synchronmesh countershaft-type gearbox, also known as a "3-shaft gearbox".

...derives from the VW Touareg, in which it has already proved successful.

... is used for engines with up to 400 Nm of torque.

The 08D gearbox was developed by, and is manufactured by ZF- Getriebe GmbH.

The 1st and 2nd gears are selected using a triple-cone synchroniser.

The 3rd, 4th and reverse gears have a double-cone synchroniser.

The 5th and 6th gears have a single-cone synchroniser.

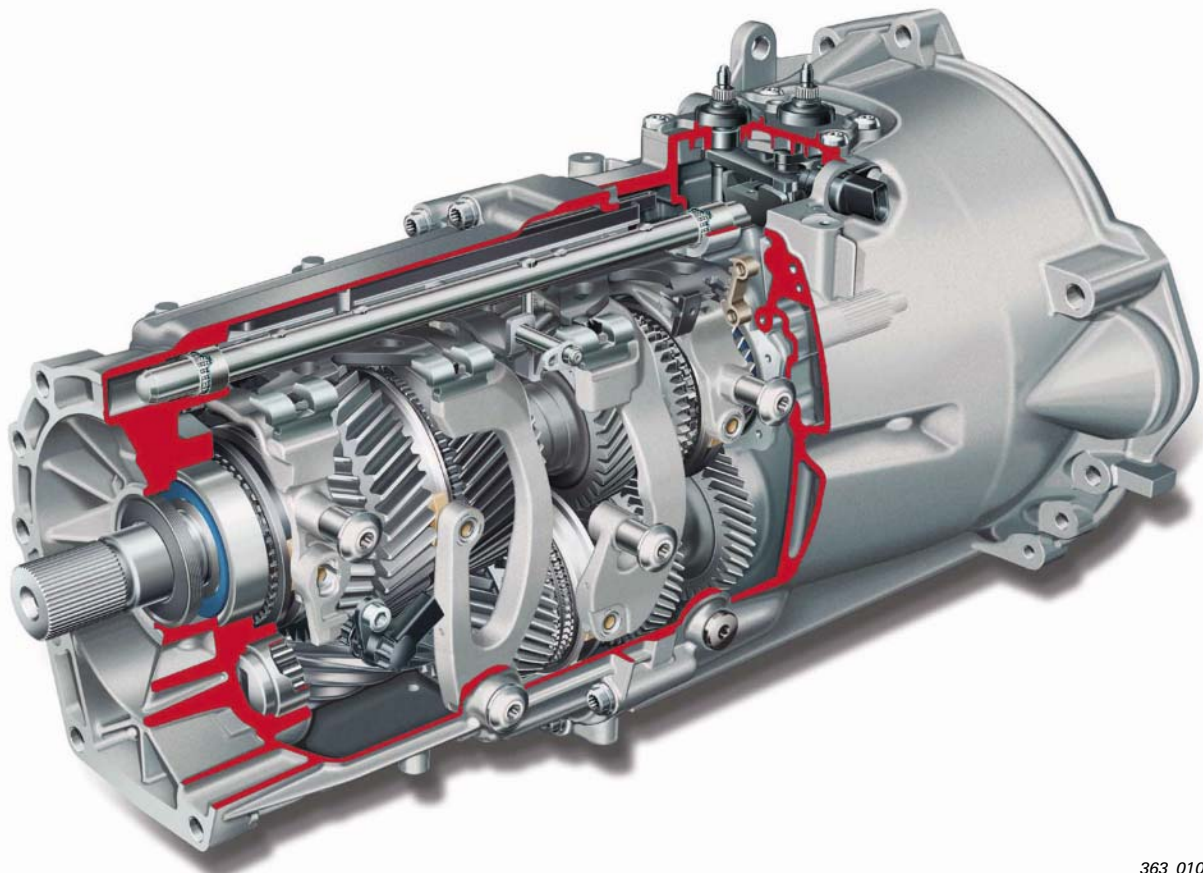

363_010

Reference



For further information on the 08D gearbox, please refer to SSP 299.

The 6-speed automatic gearbox 0AT...

... is an electro-hydraulically controlled 6-speed planetary gearbox (multi-step automatic gearbox) with hydrodynamic torque converter and slip-controlled converter lockup clutch.

The hydraulic control unit (valve body) and the electronic control unit have been combined in a unit, the so-called mechatronics. The mechatronics are located in the oil sump.

The 0AT gearbox...

...is a new development for the Audi Q7 optimised with regard to weight and fuel economy for engines with up to 400 Nm of torque.

... belongs to the same family as the 6-speed automatic gearboxes 09E and 09L

The 0AT gearbox was developed by, and is manufactured by ZF- Getriebe GmbH.

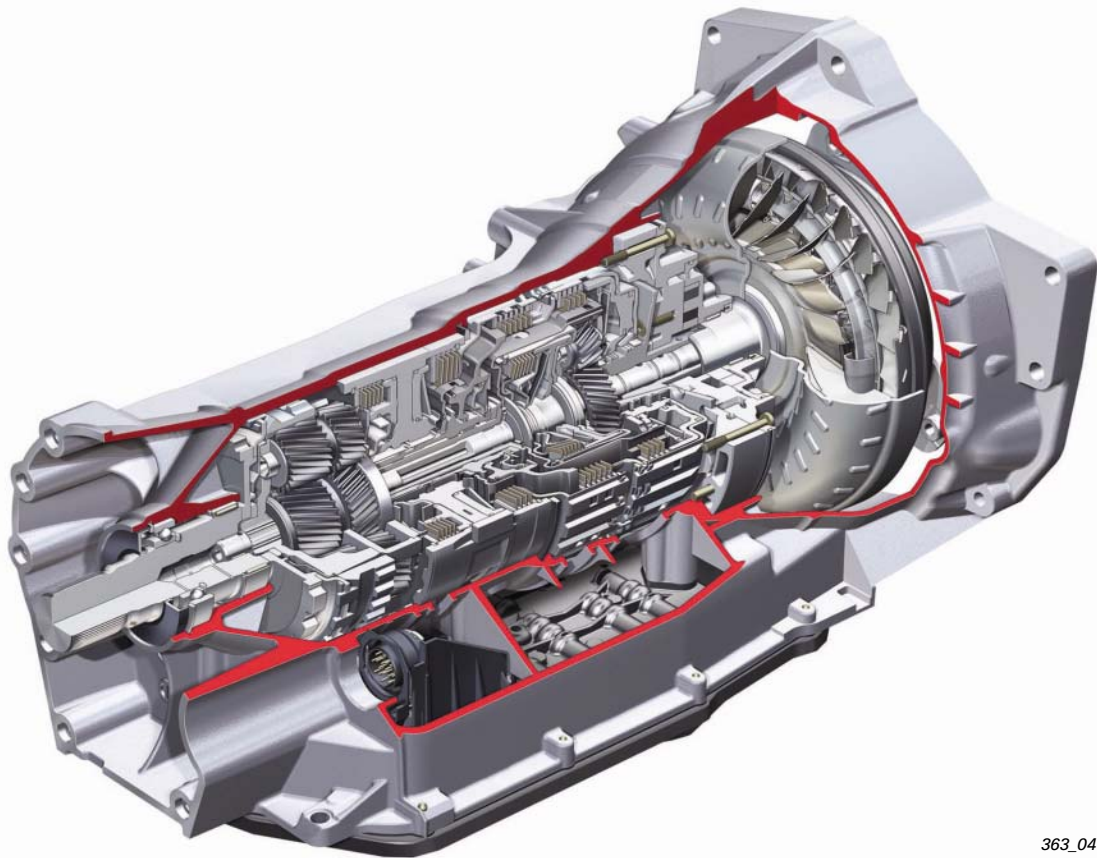

363_041

Other features:

- Special deep-seated ATF intake point and the large ATF capacity to ensure proper oil intake during off-road use.
- Extended gearbox breather pipe to prevent ingress of water into the gearbox even under adverse conditions.
- Large-sized torque converter and torque converter lock-up clutch.
- Integration of the gearbox into the immobiliser system

Reference



For further information on 6-speed automatic gearboxes 09E and 09L, please refer to SSPs 283/284 and SSP 325.

Note

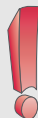

This gearbox will not be available at roll-out. Further details will be published later in a separate SSP.

Gearbox code

6-speed automatic gearbox 09D...

... is a conventional electro-hydraulically controlled 6-speed planetary gearbox (multi-step automatic gearbox) with hydrodynamic torque converter and slip-controlled converter lockup clutch.

The hydraulic control unit (valve body) is located in the oil sump, while the electronic control unit is accommodated externally in the vehicle interior (under the right-hand front seat).

The 09D gearbox...

...derives from the VW Touareg, in which it has already proved successful.

... is used for engines with up to 750 Nm of torque.

... belongs to the same family as the 6-speed automatic gearbox 09G (see SSP 291)

The 09D gearbox was developed by, and is manufactured by Japanese gearbox manufacturer AISIN AW CO., LTD.

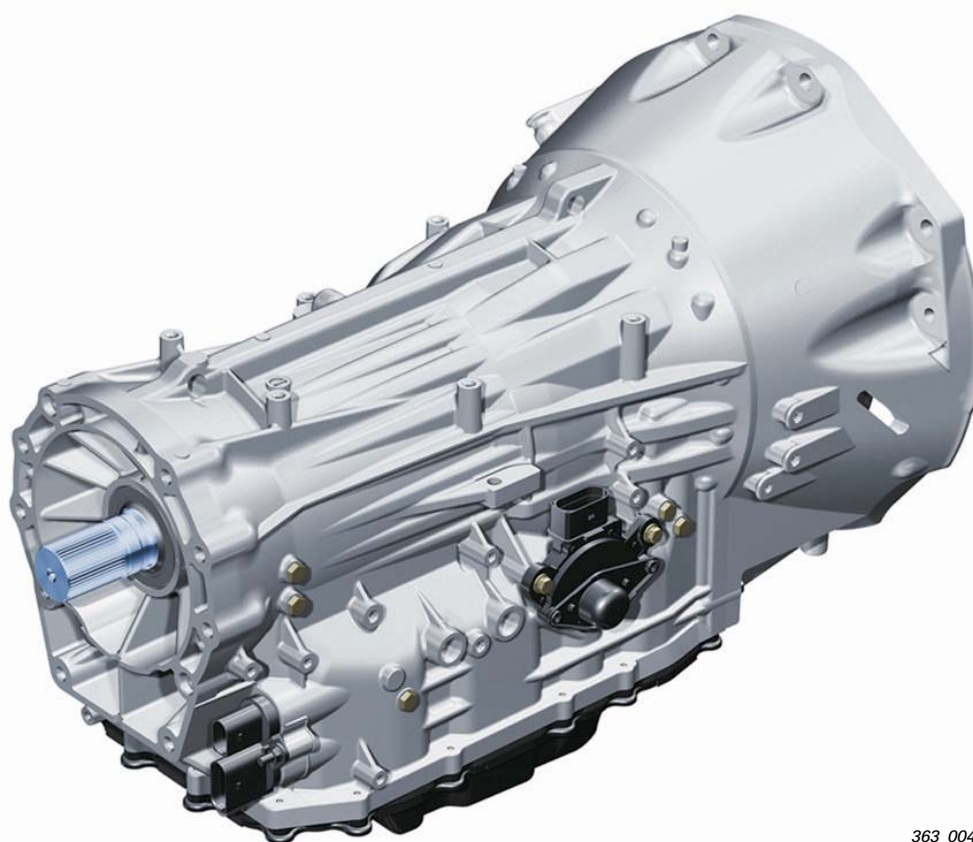

363_004

Other features:

- Special deep-seated ATF intake point and the large ATF capacity to ensure proper oil intake during off-road use.
- Extended gearbox breather pipe to prevent ingress of water into the gearbox even under adverse conditions.
- Large-sized torque converter and torque converter lock-up clutch.

Reference



For further information on 6-speed automatic gearbox 09G, please refer to SSP 291.

Gear selector mechanism

Automatic gearbox selector mechanism

The design and function of the gear selector mechanism in the Q7 are largely identical to that of the gear selector mechanism used in the Audi A6'05. The differences the gear selector mechanism used in the Audi A6'05 are listed below.

The gear selector mechanism can be removed vehicle interior for repairs (e.g. to replace microswitch F305).

When the gear selector mechanism is replaced, the selector housing (installed from the exterior) remains installed in the vehicle. Only the gear selector mechanism function unit need be replaced.



363_043

Selector lever position indicator unit Y26

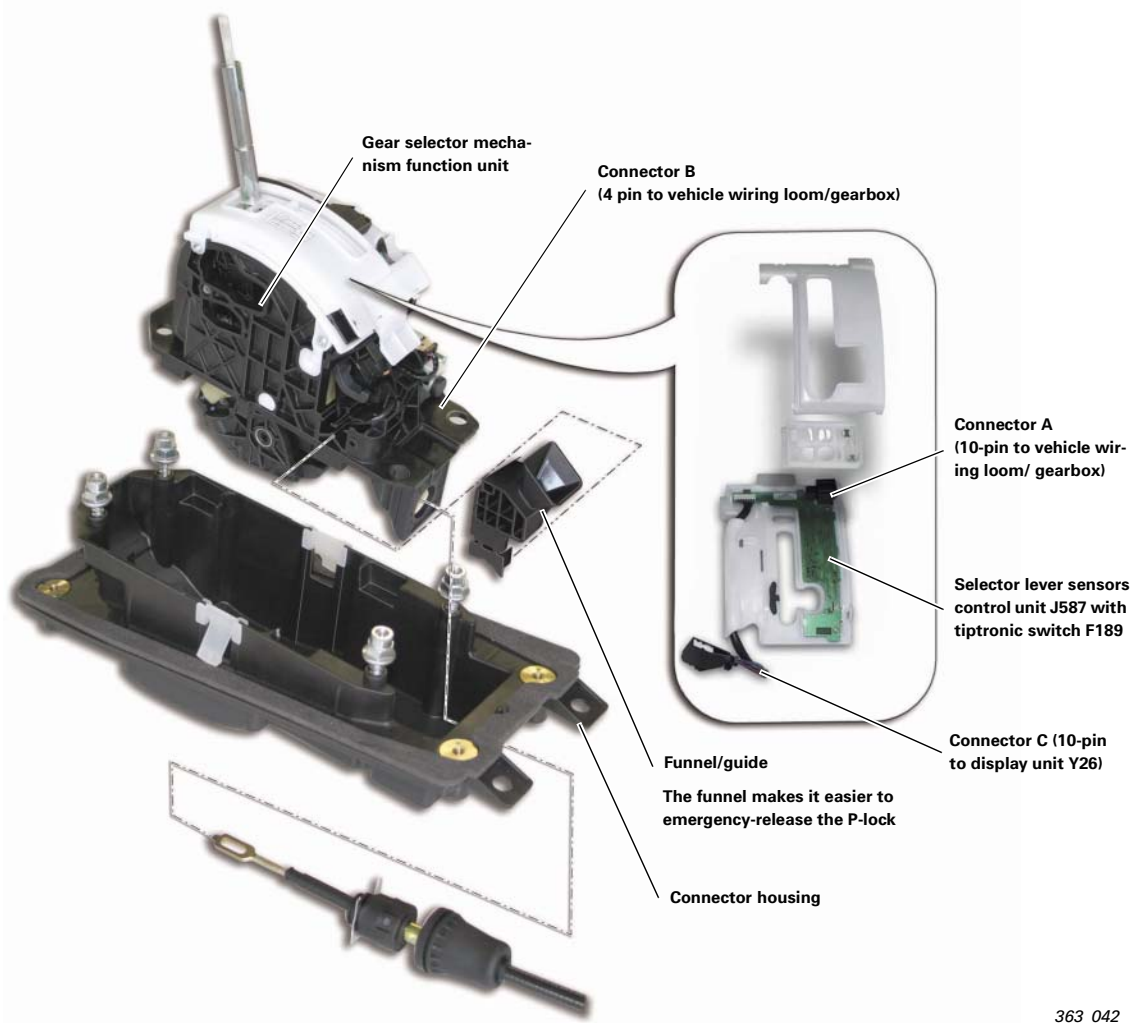

363_042

Reference



For further information on the gear selector mechanism used in the Audi A6'05, please refer to SSPs 325 and 283.

Gear selector mechanism

P/R/N/D/S signal

The selector lever sensors control unit J587 is responsible only for acquisition of the signals for the tiptronic function (tiptronic switch F189) and activation of the selector lever position indicator unit Y26. The Hall sensors used previously to determine the selector lever position for activating the display unit Y26 are no longer needed. Information on selector lever position (P/R/N/D/S signal) is now supplied directly to the selector lever sensors control unit by the gearbox control unit in the form of a frequency-modulated square-wave signal (FMR signal). The selector lever sensors control unit then activates the corresponding LEDs on display unit Y26.

A defined signal frequency is assigned to each selector lever position (see DSO images). The selector lever sensors control unit evaluates the signal and activates the corresponding LED on display unit Y26 (earth activation).

The advantages of this new feature are:

- Synchronous indication of selector lever position in the dash panel insert and on the selector lever.
- Cost savings through simplification of the selector lever sensors control unit J587 (elimination of additional Hall sensors).

Function diagram of the gear selector mechanism with 09D gearbox

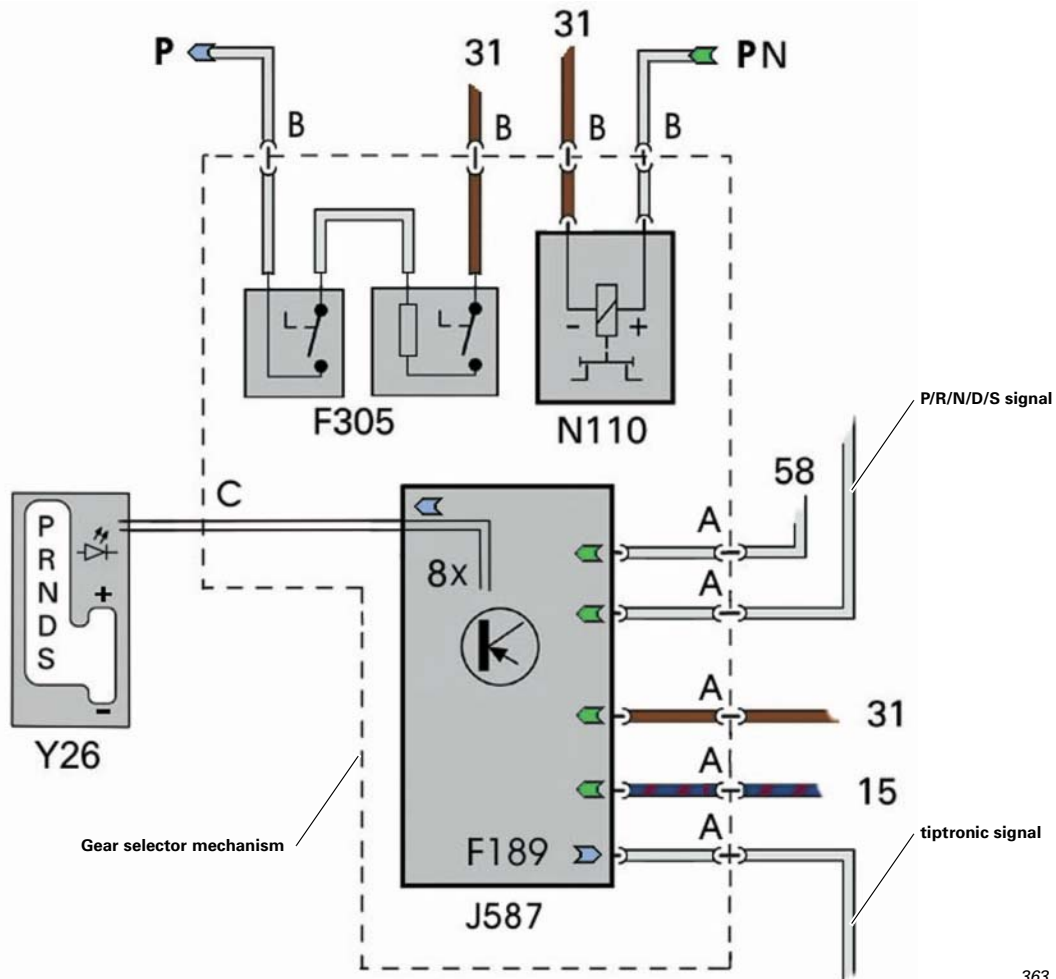

363_044

- F189** Tiptronic switch
- F305** Gear selector position P switch
- F189** Tiptronic switch
- J587** Selector lever sensors control unit
- N110** Selector lever lock solenoid
- Y26** Selector lever position indicator unit

DSO images of P/R/N/D/S signals

DSO connection:

- black probe tip, Pin 6*
- red probe tip, Pin 9*

* Pin to connector A or test adapter V.A.G. 1598/42

Test equipment:

- V.A.G 1598/54 with
- V.A.G 1598/42
- VAS 5051

Test conditions:

- Ignition "ON"

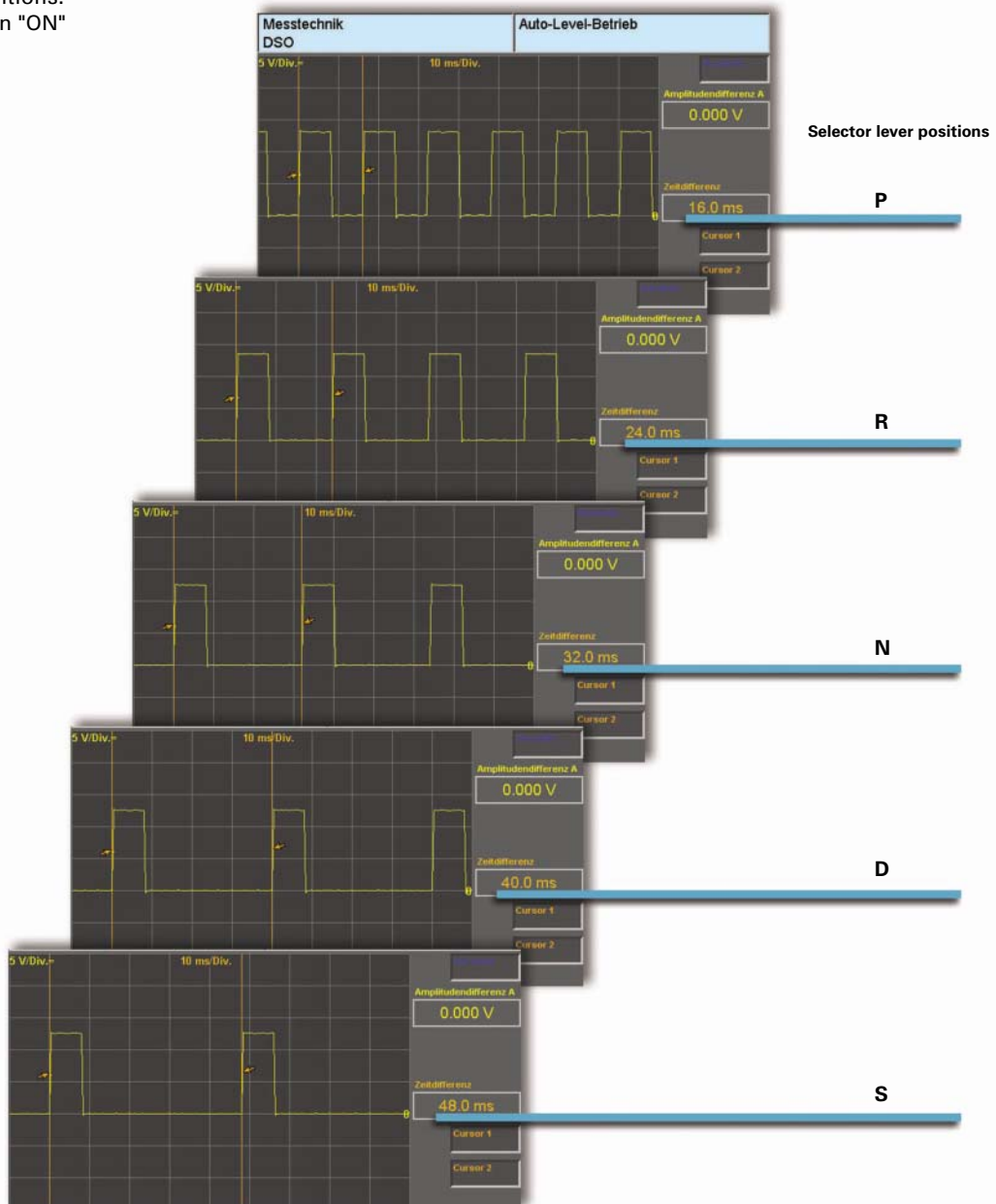

363_045

Gear selector mechanism

tiptronic signal

The information on selector lever in tiptronic gate, selector lever in Tip+ or selector lever in Tip- is transmitted to the gearbox control unit in the form of a frequency-modulated square-wave signal (FMR signal) along a discrete line (see DSO images).

Advantages of this new feature:

- Higher operational reliability - only one line is required to the control unit (instead of three), hence there are fewer potential sources of fault.
- Better self-diagnostics.

The signals and from to the **gear selector mechanism** can be tested by using test adapter V.A.G. 1598/54 in combination with test box V.A.G. 1598/42.

The signals to and from **09D gearbox** can be tested by using test adapter V.A.G. 1598/48 in combination with test box V.A.G. 1598/42.

The signals to and from the **0AT gearbox** can be tested by using test adapter V.A.G. 1598/40 in combination with test box V.A.G. 1598/14.

Reference



For further information on the tiptronic signal and the tiptronic switch F189, please refer to SSP 291, from p. 50).

Apart from the different signal waveform, the selector mechanism has the same basic function as the selector mechanism used in the Audi A3'04.

DSO images of the tiptronic signal

DSO connection:

- black probe tip, Pin 6*
- red probe tip, Pin 3*

* Pin to connector A or test adapter V.A.G. 1598/42

Test equipment:

- V.A.G 1598/54 with
- V.A.G 1598/42
- VAS 5051

Test conditions:

- Ignition "ON"

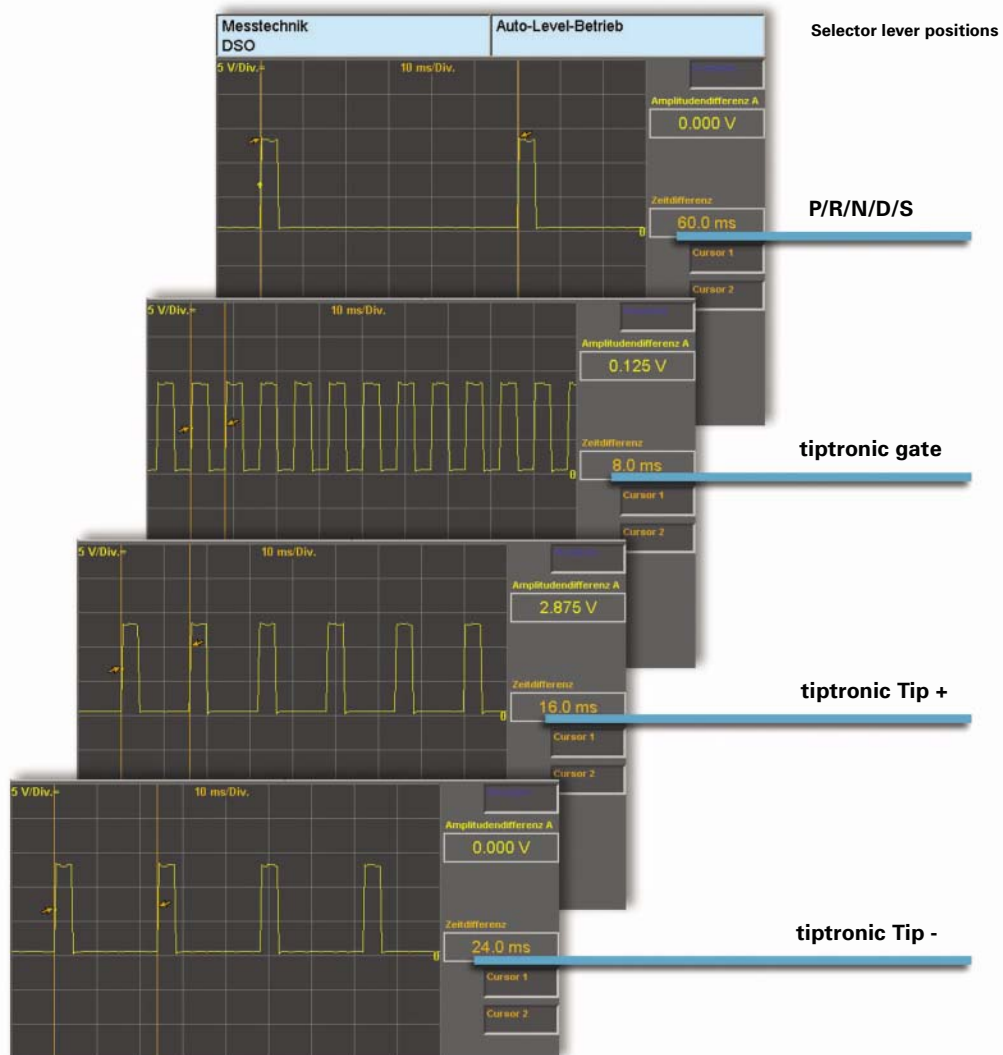

363_046

Transfer case 0AQ

Transfer case 0AQ

The development goal for the new transfer case 0AQ was to design a function and weight optimised gearbox that underscores the sporty and agile character of the Q7.

Despite the lack of a reduction step, the vehicle should have sufficient traction during off-road use to meet the requirements of an off-road vehicle.

Transfer case 0AQ has the following outstanding features:

- Latest differential generation, with asymmetric/dynamic torque distribution
- Unlimited compatibility with all vehicle dynamics control systems of the ESP
- Fully mechanical system with highreliability
- Designed for engines with up to 750 Nm of torque
- Weighing only approx. 31 kg, it has an exceptionally low power-to-weight ratio
- Maintenance-free lifetime lubricated gearbox

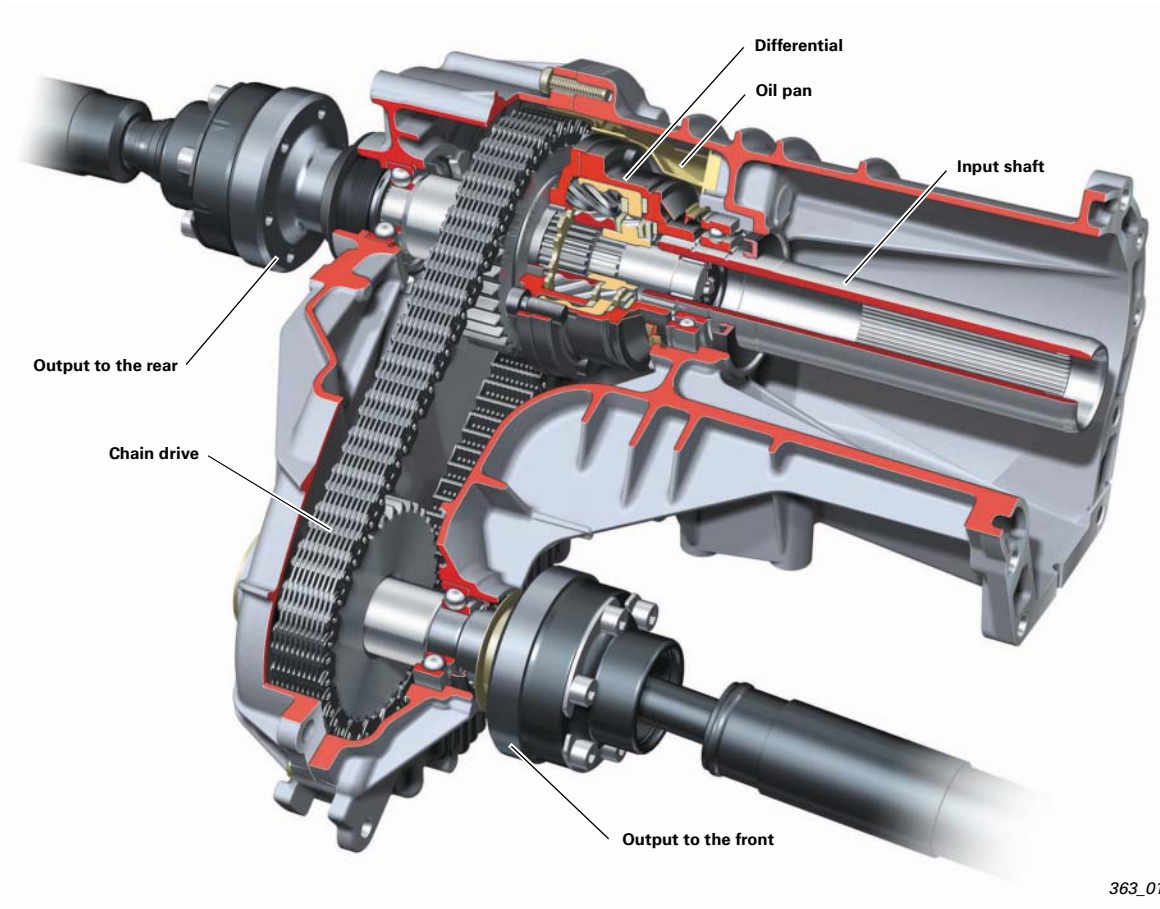

363_012

Design / function

The transfer case attaches directly to the respective automatic or manual gearbox. Three different "lengths of neck" compensate for the different gearbox lengths.

The input shaft, designed as a hollow shaft, transmits the engine torque to the differential. The differential equalises differences in speed between the axles and distributes the driving torque.

Drive power is transmitted to the rear axle by the differential via the output shaft, which is aligned coaxially to the input shaft. The front axle torque is transmitted to the upper chain sprocket. The chain sprocket is rotatably mounted on the upper output shaft and drives the lower chain sprocket by means of a chain.

The lower chain sprocket is attached non-rotatably to the flange shaft and acts as the output to the front axle differential.

Cutaway view of transfer case

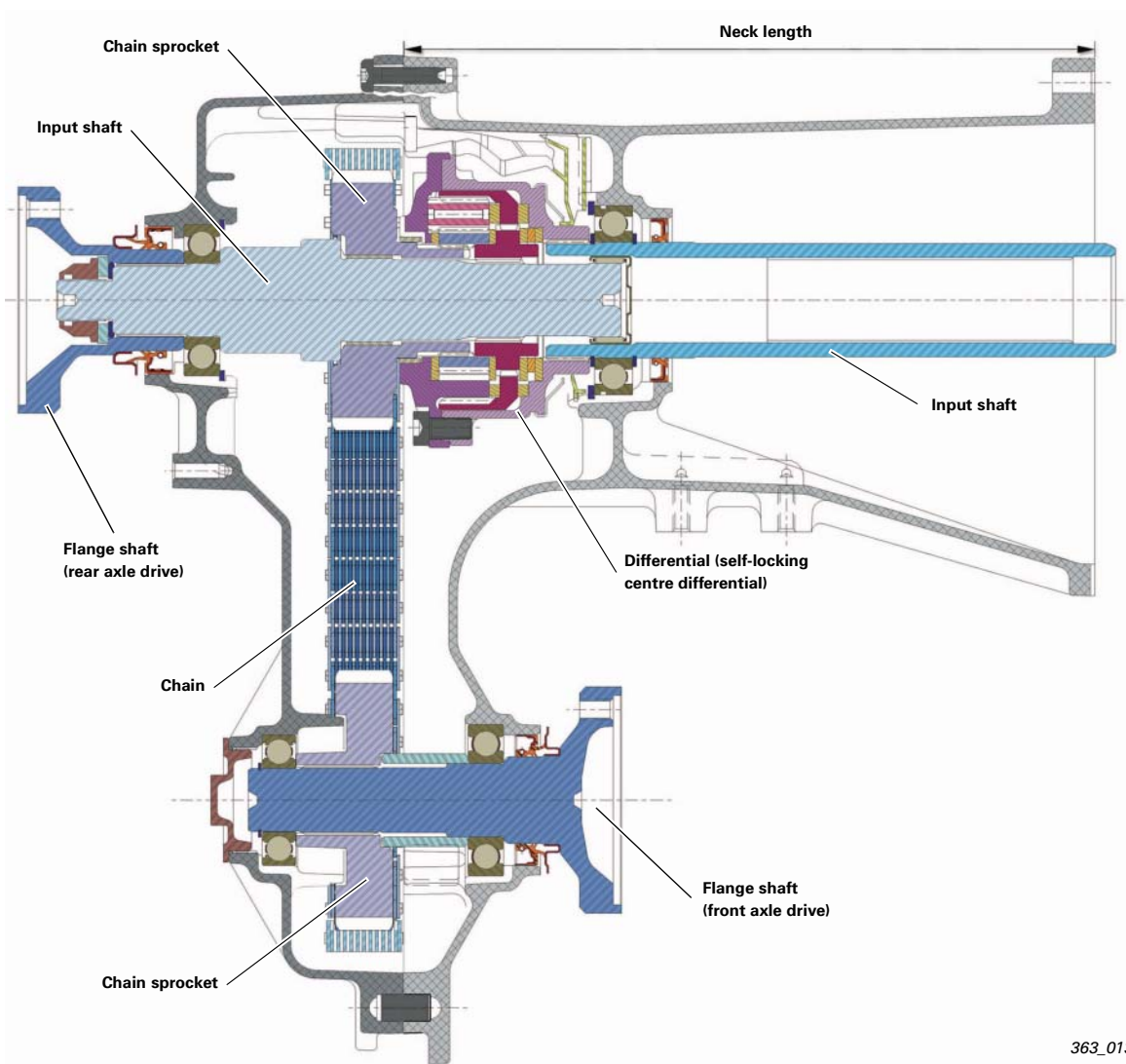

363_013

Transfer case 0AQ

Self-locking centre differential

Introduction

The newly developed 3rd generation centre differential is used in the Q7. As with its predecessors, it is designed as a self-locking differential. The asymmetric/dynamic torque distribution is a new feature. The self-locking centre differential is designed as a planetary gear.

An asymmetric basic torque distribution of 42% to the front axle and 58% to the rear axle is ideal from the viewpoint of well-balanced driving dynamics.

A friction torque proportional to the driving torque is generated in the differential. This in turn produces a locking torque. The locking torque and the basic torque distribution result from the torque distribution to the axles.

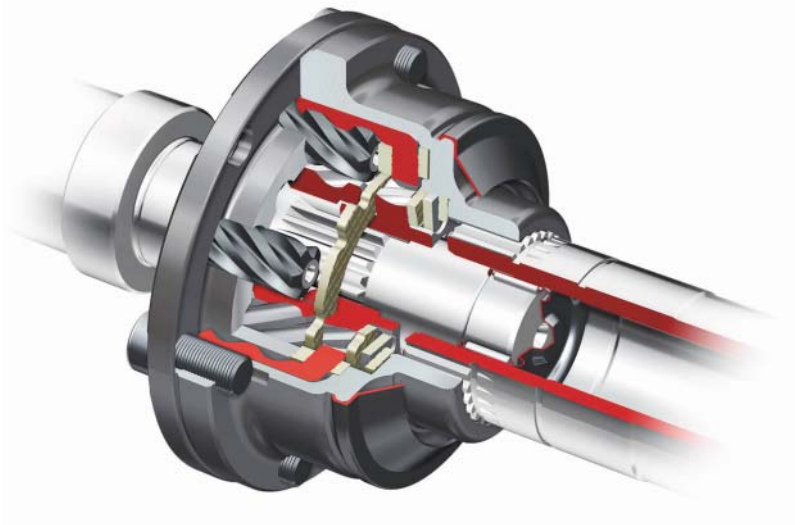

363_014

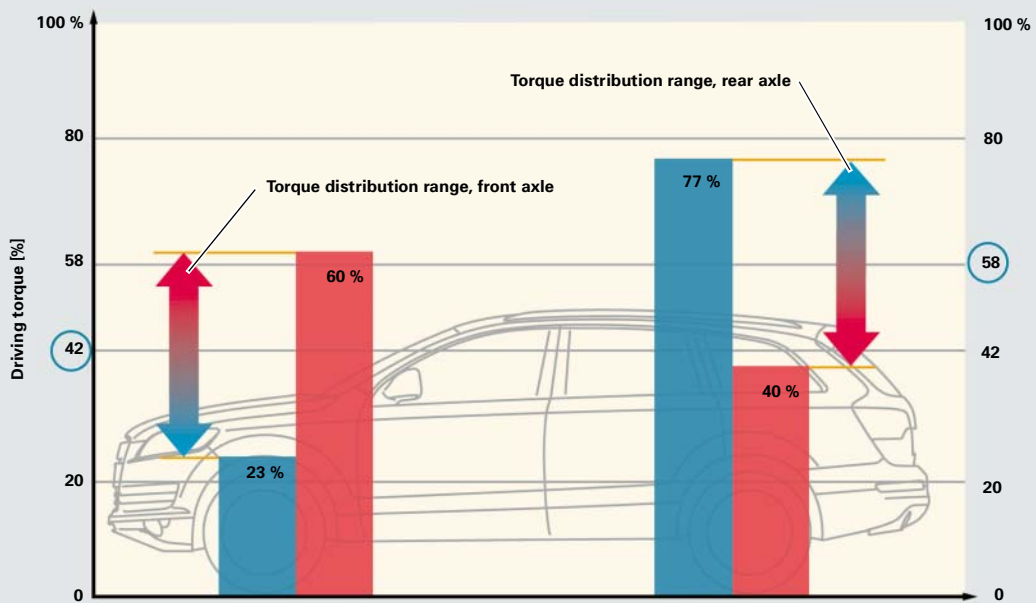

■ Max. torque distribution to rear axle (without EDL control system)
■ Max. torque distribution to front axle (without EDL control system)

363_015

Components overview

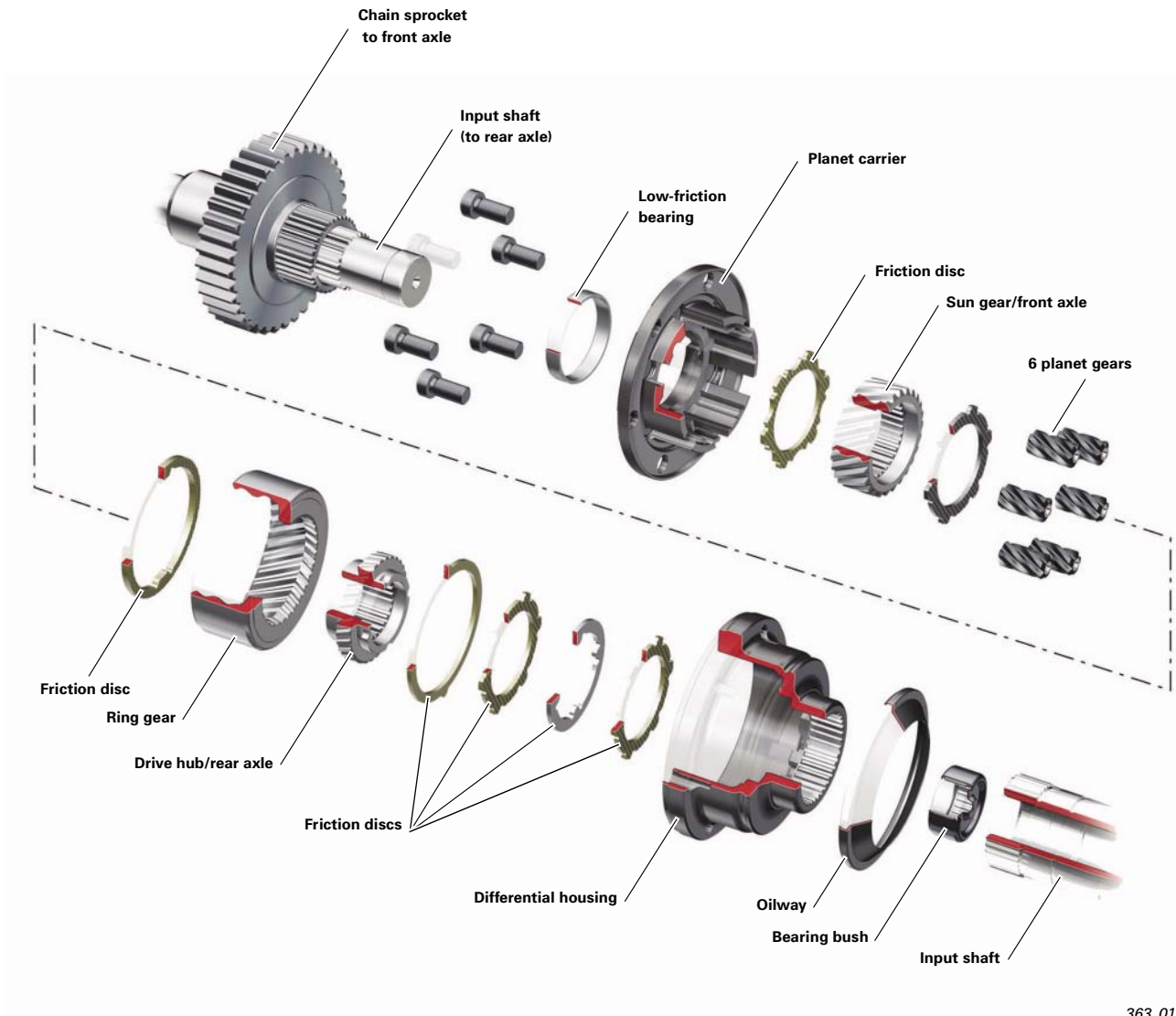

363_017

Transfer case 0AQ

Design / function

The basic design of the self-locking centre differential is identical to that of a simple planet gear train with sun gear, planet gears, planet carrier and ring gear. The planet gears are mounted on the planet carrier. The driving torque is transmitted via the planet carrier.

The planet gears engage between the sun gear and the ring gear. The ring gear connects to the rear axle drive. The sun gear connects to the front axle drive.

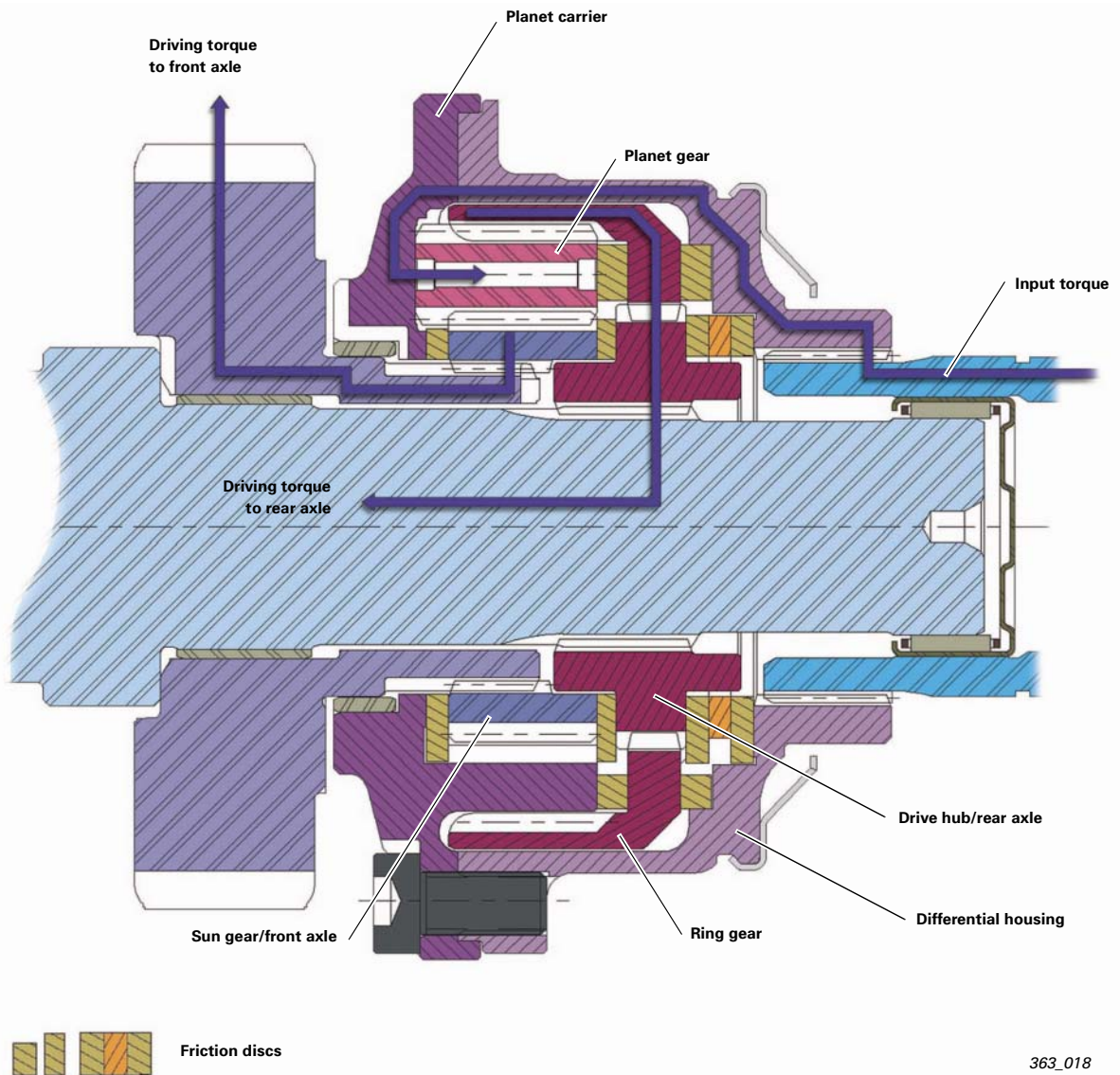

Asymmetric basic torque distribution

The asymmetric basic torque distribution of 42:58 (front axle/rear axle) results from the different pitch circle diameters of the sun gear (drive to front axle) and the ring gear (drive to rear axle).

1 = small pitch circle diameter = **short lever arm** = low torque (front axle).

2 = large pitch circle diameter = **long lever arm** = high torque (rear axle)

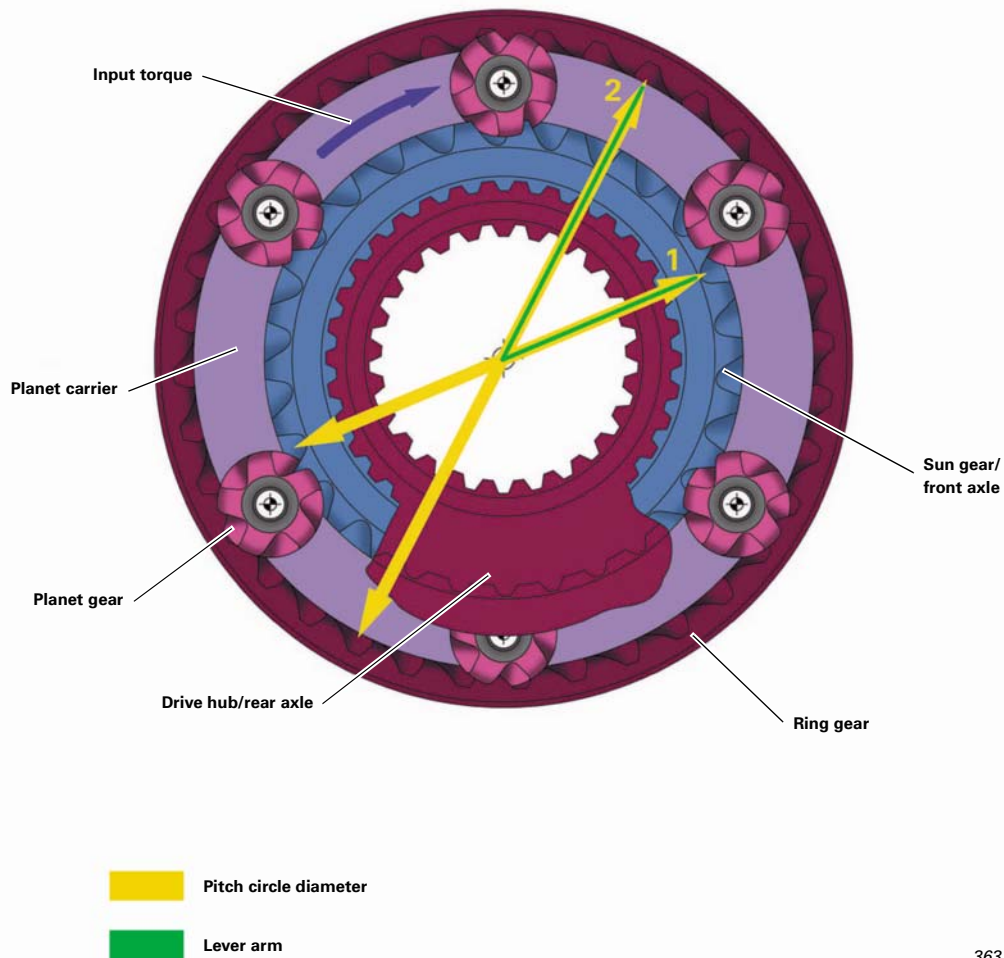

363_019

Transfer case 0AQ

Asymmetric/dynamic torque distribution

In addition to the asymmetric basic torque distribution of 42:58, a friction torque proportional to the driving torque is generated in the differential resulting in a corresponding locking torque. Locking torque plus basic torque distribution is the determining factor for the maximum torque distribution to the axles.

Basically, the centre differential responds to changes in torque at the axles. If an axle loses traction, the driving torque is redirected instantaneously to the other axle within the torque distribution limits.

If the working limits of the centre differential are exceeded, the EDL control engages and provides forward traction.

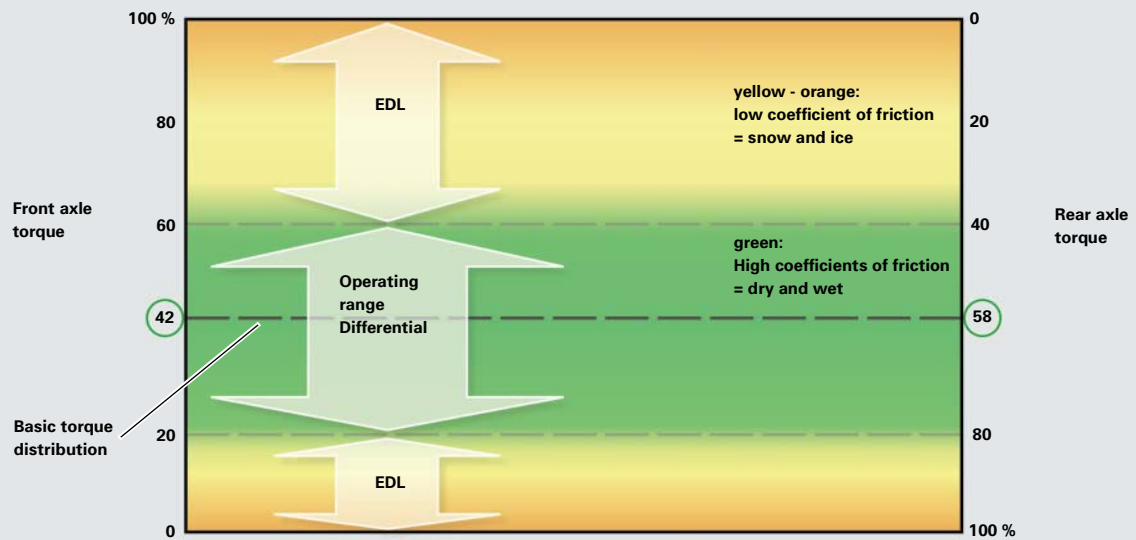

Asymmetric/dynamic torque distribution in the self-locking centre differential (under throttle)

363_016

A self-locking centre differential is characterised by four operating states: Maximum distribution to front axle and maximum distribution to rear axle while driving under throttle and while coasting (overrun).

These four operating states are characterised by four locking ratios, which can be configured differently.

Asymmetric/dynamic torque distribution

The gears of the differential have a defined helical-cut gear form. Thus, the driving torque produces an axial force which acts upon the gears, which, in turn, act upon various friction discs and generate friction. The friction, in turn, produces the desired lock-up effect.

The magnitude of the lock-up effect is defined by the locking ratio. The locking ratio is the factor* by which the driving torque is transmitted to the axle which can transmit the greater driving torque.

* number or quantity that is multiplied by another (multiplicand).

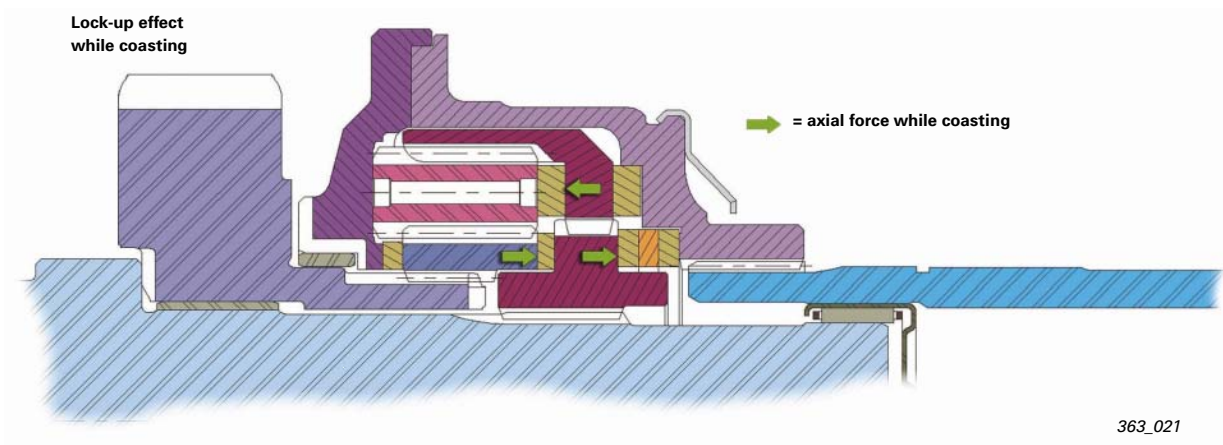
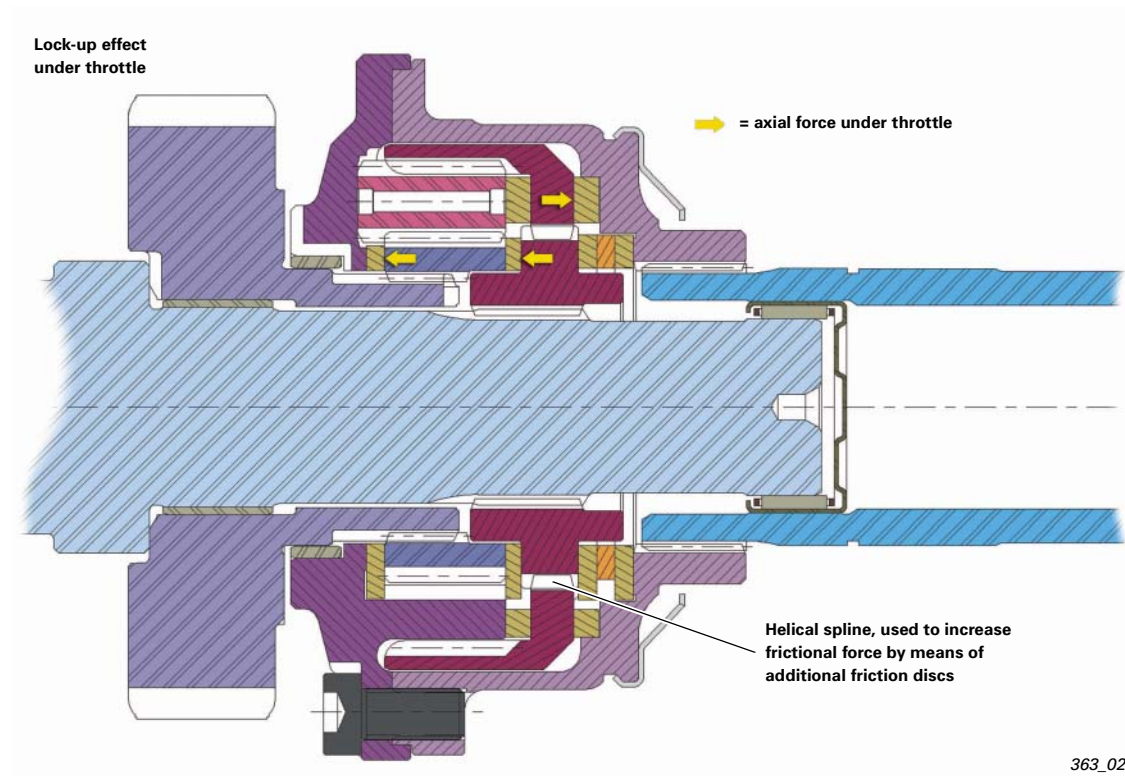

Transfer case 0AQ

Example of dynamic torque distribution

In the following example, it is explained how the Q7 responds to changing road conditions. The torque distribution of a vehicle with an open centre differential (without lock-up effect) is shown on the next page as a comparison.

In both cases, the basic torque distribution is 42% to the front axle and 58% to the rear axle.

Audi Q7 self-locking centre differential: traction limit* icy surface 250 Nm

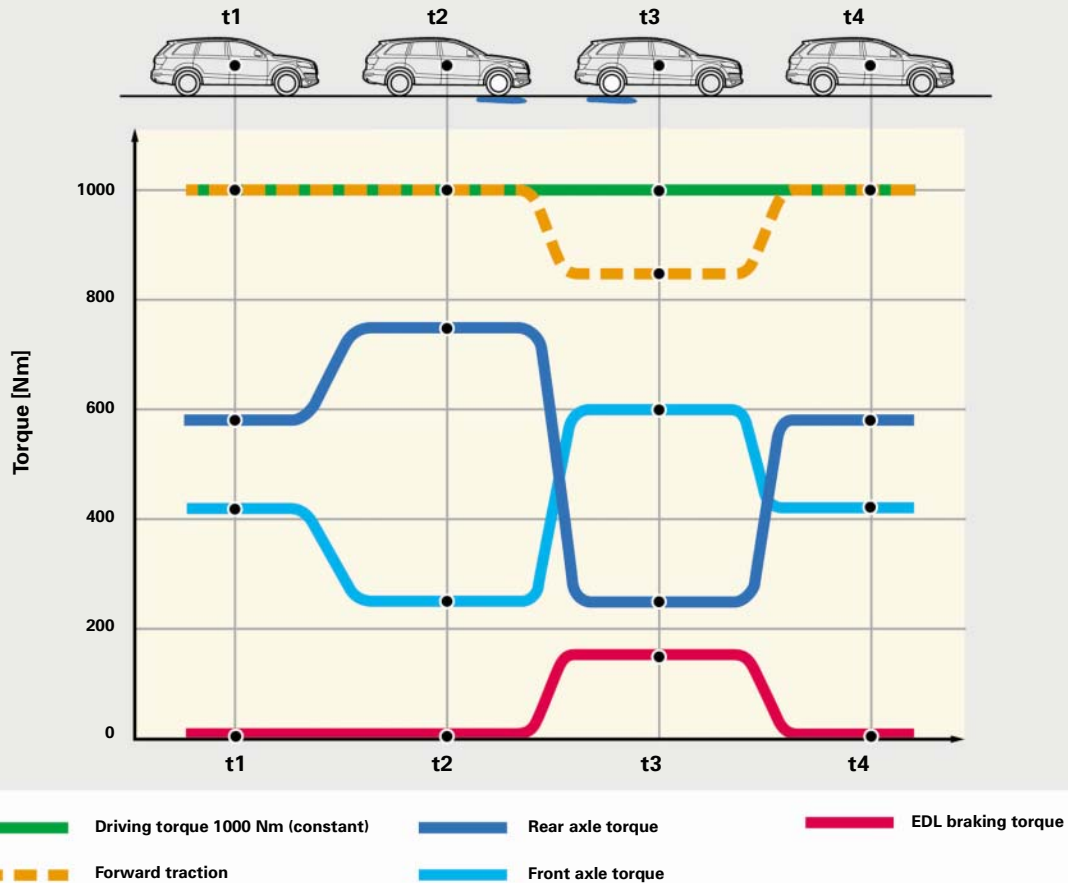

363_022

In this example, the Q7 passes over a small patch of ice (driving conditions t2 and t3) under constant driving power. The traction limit* is assumed to be 250Nm per axle. The total driving torque (t1 and t4) is 1000 Nm.

When the vehicle passes over a patch of ice (t2), the front axle loses traction, thus reducing the driving torque to the traction limit* of 250 Nm. Due to the lock-up effect of the differential, the driving torque distributed to the rear axle increases simultaneously to 750 Nm. As the torque distribution is within the torque distribution range, no speed differential occurs between the axles.

100% of engine power is converted to forward traction; the EDL control does not have to take countermeasures. At time t the front axle has already passed over the patch of ice. Now the rear axle now has to deal with the reduced friction and can only transfer 250 Nm of torque. To ensure optimal traction at the front axle, the EDL control now comes to the assistance of the front axle. 85% of engine power is converted to forward traction.

* maximum amount of torque transferable to an axle on the patch of ice

Example of static torque distribution

Like in the example on the previous page, a vehicle drives over a patch of ice with the centre differential open under the same marginal conditions (total driving torque 1000 Nm, traction limit* of icy surface 250Nm/ axle).

The torque distribution is identical: 42% to the front axle and 58% to the rear axle.

Vehicle with open centre differential, torque split 42/58 traction limit* of icy surface 250 Nm

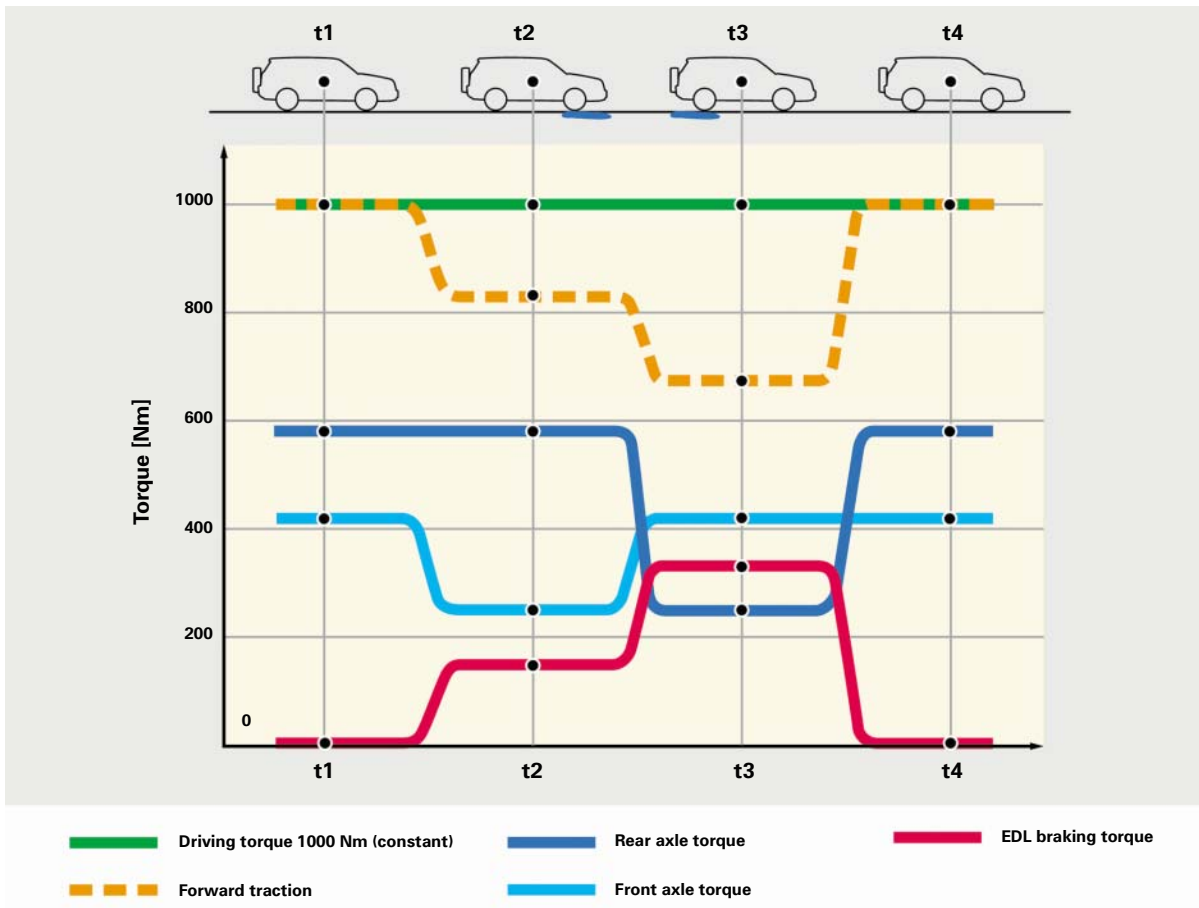

363_023

The front axle initially loses traction (t2). The EDL control must take countermeasures in order to maintain the torque to the axle with the higher coefficient of friction (rear axle). 17% of engine power is redirected away from the front axle, thus reducing forward traction to the same extent.

If the rear axle passes over the patch of ice at time t3, the EDL control has to apply additional countermeasures to prevent wheelspin from occurring. The loss of forward traction is now 33%.

* maximum amount of torque transferable to an axle on the patch of ice

Transfer case 0AQ

The chain drive

The chain drive transmits the driving torque to the front axle. A specially developed "gear chain" with associated chain sprockets is used.

The chain drive in the 0AQ transfer case has the following features:

- High transferable torque
- Constant speed
- Smooth running
- Maintenance free
- High efficiency

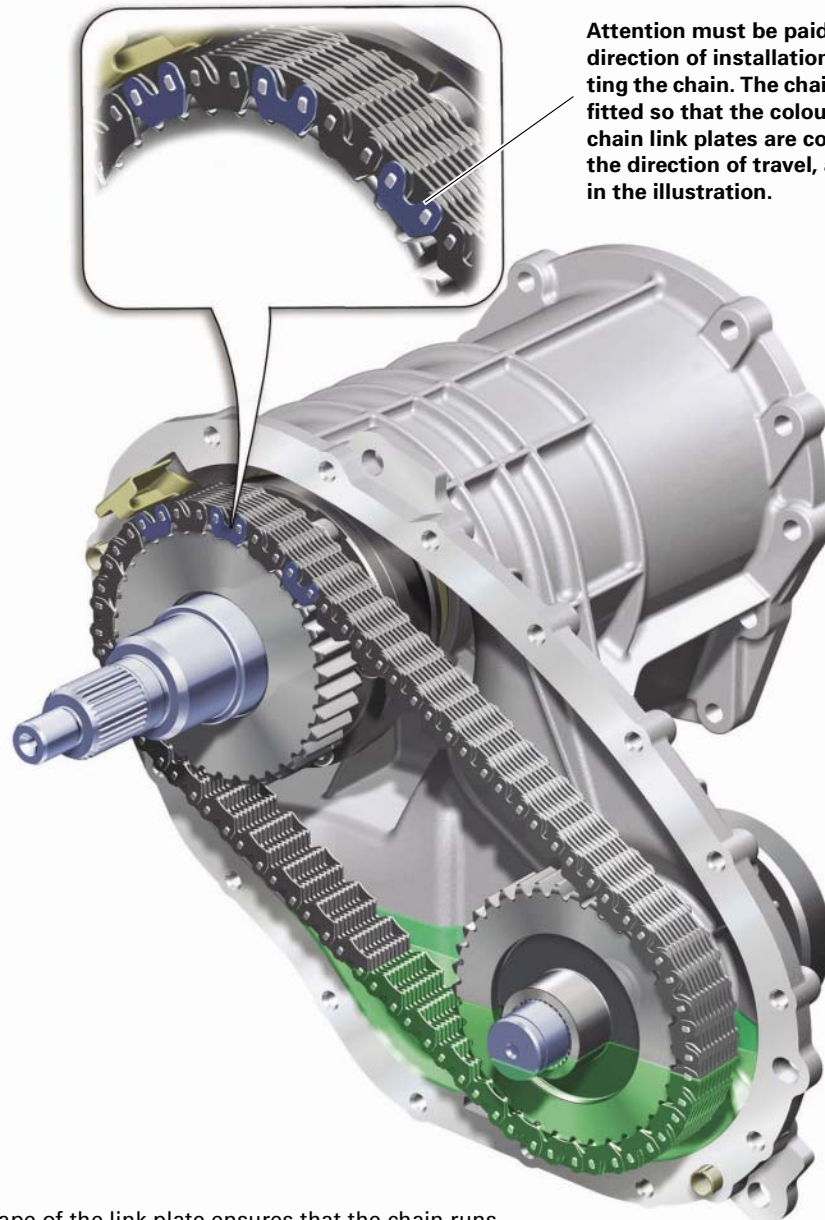

Attention must be paid to the direction of installation when fitting the chain. The chain must be fitted so that the colour-coded chain link plates are counter to the direction of travel, as shown in the illustration.

The special shape of the link plate ensures that the chain runs smoothly even at high chain speeds. The layout of the chain link plates, with two different tooth flanks and the relatively high, uneven number of teeth on the sprockets, provides a marked improvement in acoustic quality.

363_035

Design and function of the gear chain

The gear chain consists of the juxtaposed chain link plates which are continuously joined by two cradle pins. The lateral chain link plates ensure that the chain runs true.

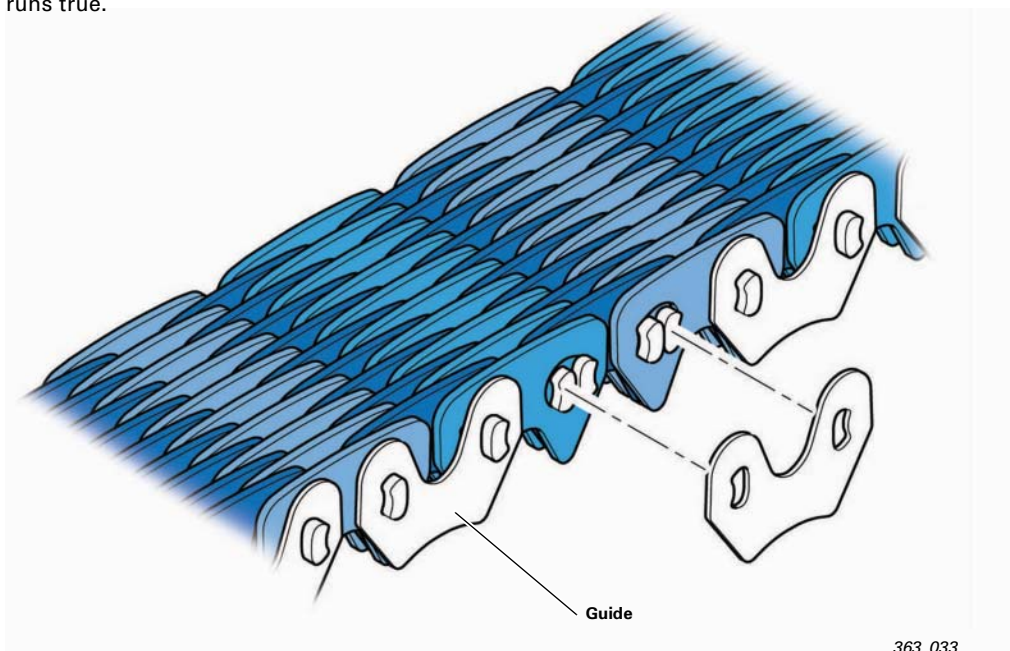

363_033

This is how it works:

Each cradle pin is attached non-rotatably to a row of link plates. Two cradle pins form a so-called cradle-type joint.

As the chain curves around the sprocket, the chain links roll off the cradle pins. Thus, the chain curves around the sprocket almost without producing any friction.

Despite high torque and continuous operation, wear is reduced to a minimum and efficiency is increased.

The chain drive is designed to last the service life of the vehicle.

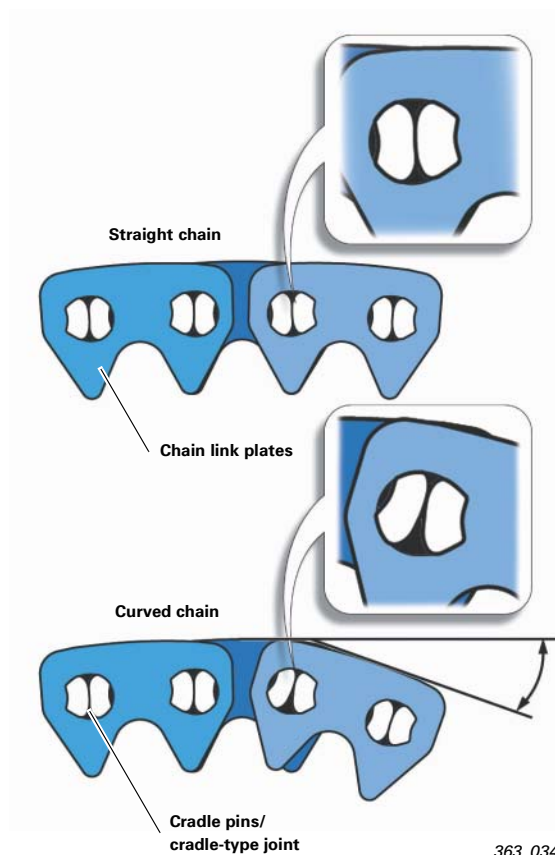

363_034

Transfer case 0AQ

Lubrication

The design of the 0AQ transfer case allows the use of automatic transmission fluid (ATF) for lubrication purposes.

ATF is notable for its low and constant viscosity over a large temperature range.

The vehicle is lifetime lubricated with ATF.

The installation position of the transfer case as well as the implementation of a low oil level requires that special measures be taken with regard to lubrication of the differential and the overhead lubrication points.

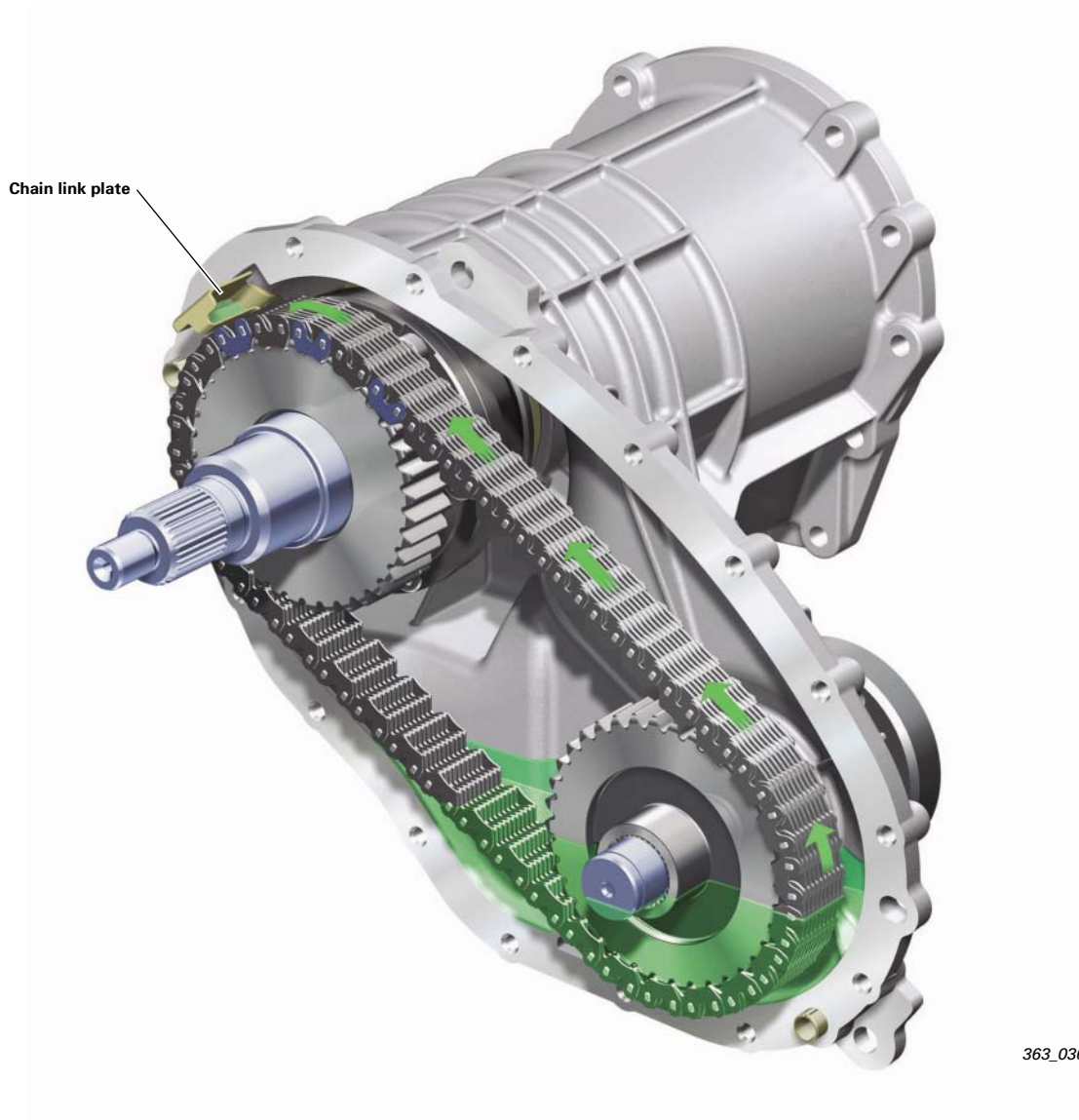

363_036

This is how it works:

The upper shafts and the differential are oiled using an oil pan and directional oilways.

During vehicle operation, the chain delivers the oil upwards where it is skimmed off by the oil pan. The oil flows along an elaborate oilway into the differential and to the input shaft bearing. This ensures sufficient oil delivery even when driving at walking speed. The system also operates when the vehicle is reversing.

A circular "oil ring" forms in the differential due to the centrifugal force acting upon the oil. When the vehicle is stationary, this oil ring collapses and lubricates the inner lubrication points.

The differential housing is designed in such a way that a certain amount of oil remains when the vehicle is at a standstill. This ensures that the system is always lubricated properly when driving away.

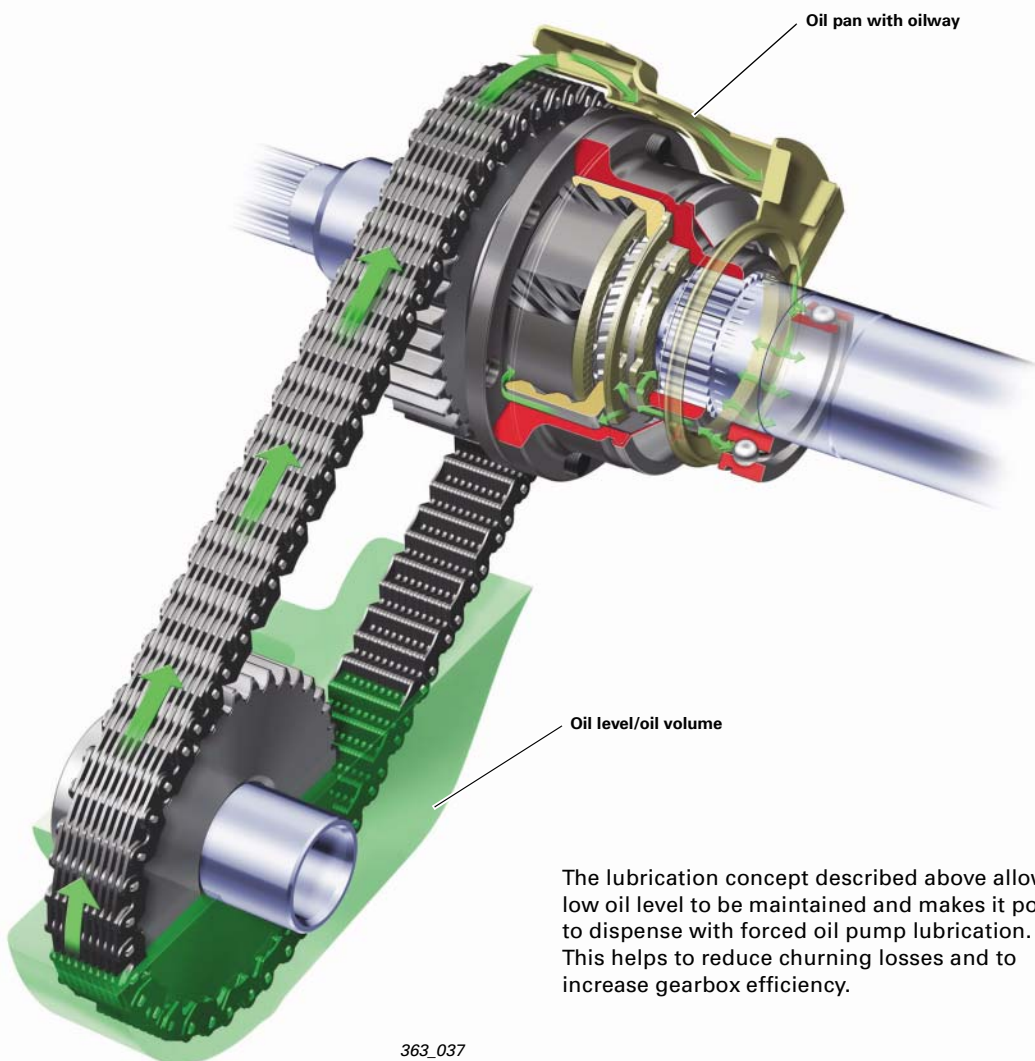

363_037

The lubrication concept described above allows a low oil level to be maintained and makes it possible to dispense with forced oil pump lubrication. This helps to reduce churning losses and to increase gearbox efficiency.

Note



When repairing the transfer case, attention must be paid to contamination of the oil pan. The oilway must be cleaned as required.

Transfer case 0AQ

Oil supply / sealing

In adverse offroad conditions, special demands are made of the sealing of the front axle differential, as well as the rear axle differential and the transfer case flange shafts. This is why shaft oil seals with special dust and moisture seals are used.

The sealing of the flange shafts is shown here using the 0AQ transfer case as an example.

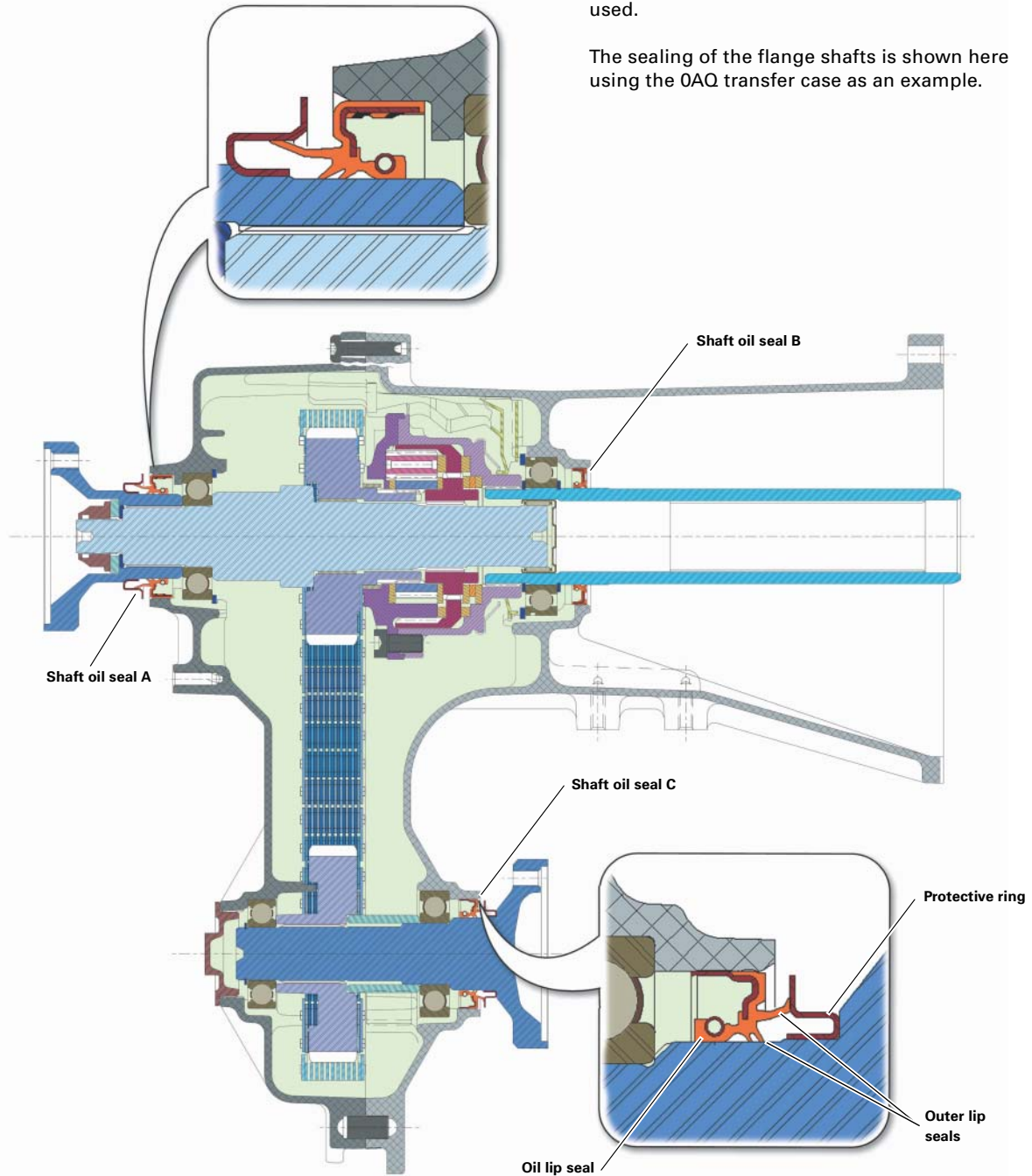

363_038

A press-fitted protective ring on the flange shaft acts as a "deflector ring" and helps to keep dirt and water away from the lip seals during vehicle operation.

The outer lip seals help to prevent dust and moisture coming into contact with the oil lip seal and its liner.

Service / special tools

To avoid having to replace shaft oil seals shafts or flange shafts, the shaft oil seals must be press-fitted more deeply than in series production.

As a result, the lip seal of the shaft oil seal runs on a new liner. This ensures less load on the sensitive lip seal, which, in turn, extends seal life and improves sealing performance.

Shaft oil seal A

Series production > press-fitted flush

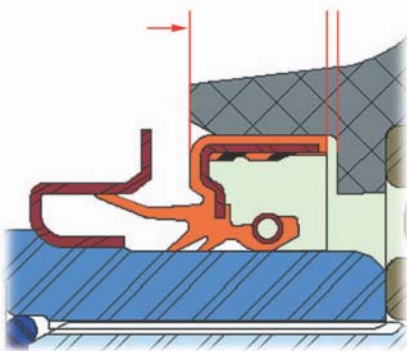

363_047

Service > press-fitted to the limit.

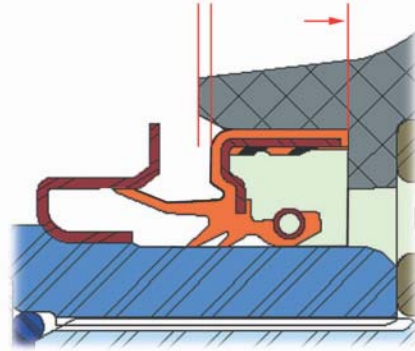

363_048

Pressing tool
T 40115

Shaft oil seal B

Series production > defined measurement

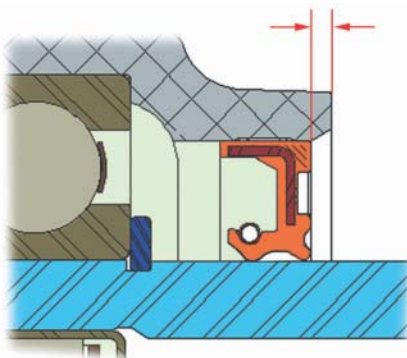

363_049

Service > defined deeper measurement

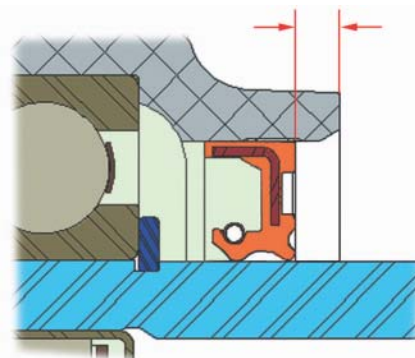

363_050

Pressing tool
T 40113

Shaft oil seal C

Series production > defined measurement

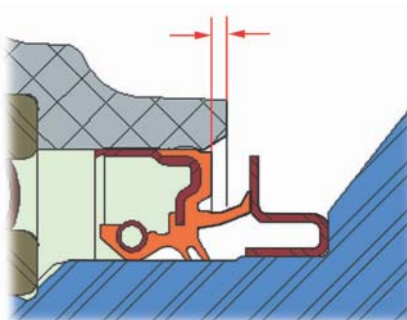

363_051

Service > defined deeper measurement

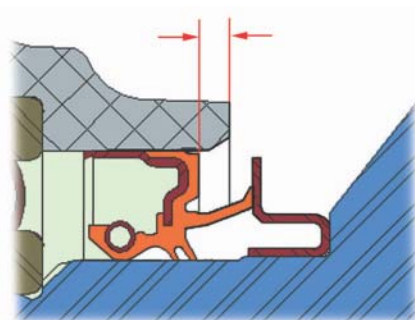

363_052

Pressing tool
T 40114

Useful information

Operating instructions

- The self-locking centre differential cannot be compared to a 100% mechanical differential lock. If an axle or a wheel begins to spin, no drive is provided until the EDL control (electronic differential lock) engages.
- The EDL control engages as of a defined speed difference between the wheels. Throttle must be applied until the EDL control builds up additional torque by means of brake application. This additional torque will then be available to the opposite wheel. The self-locking centre differential assists the EDL control by transmitting additional braking torque to the other axle, where possible. To prevent overheating of the brake due to prolonged braking intervention by the EDL, the EDL will be deactivated as of a max. brake disc temperature calculated by the ESP control unit.
- The self-locking centre differential will become damaged if the system constantly has to equalise the speeds of the front and rear axles in combination with a high engine load.
- If one of the two prop shafts is removed, no drive will be available.
- Snow chains may only be fitted to the rear wheels.



363_040

Reference



For further information on the EDL control, please refer to the section on the "Offroad mode"



363_039

Electronic Differential Lock EDL

One of the main priorities for the setup of electronic differential locks which work by braking intervention (EDL) is the build-up of a locking torque with a minimum of wheel slip.

On introduction of the EDL, the wheel speed control parameters were the main consideration. To protect the engine against stalling due to brake application, relatively high wheel differential speeds were necessary.

Engagement of the EDL control was at a defined wheel differential speed in dependence on the vehicle's road speed.

Since the introduction of the ESP, engagement of the EDL control is based on a so-called torque balance. The brake force to be applied is determined by making allowance for available engine torque and the amount of torque transferable to the individual wheels.

The following rule generally applies here:
If a high engine torque is available, the EDL can engage at lower wheel differential speeds than at a low engine torque.

The EDL can engage up to a speed of 100 kph.

Reference



For further information, please refer to SSP 241

Offroad mode

The ESP Offroad mode can be activated, as required, by pressing the ESP button.

The purpose of the ESP Offroad mode is to improve ESP, TCS, ABS and EDL performance on loose surfaces (offroad) and to provide the driver with optimum deceleration and traction.

Special auxiliary functions such as deactivation of the trailer stabilisation system, a special "ABS for reversing", and the "downhill assist" function assist the driver in challenging terrain or on loose surfaces.

In Offroad mode, the EDL activation threshold is reduced in order to optimise traction. Thus, the EDL engages even at a low wheel speed differential.

Reference



For further information on the Offroad mode, please refer to SSP 262

All rights reserved.
Technical specifications
subject to change without
notice.

Copyright
AUDI AG
I/VK-35
Service.training@audi.de
Fax +49-841/89-36367

AUDI AG
D-85045 IngoIstadt
Technical status: 11/05

Printed in Germany
A05.5S00.16.20