

Valve gear, servicing

Notes:

- ◆ *Cylinder heads which have cracks between the valve seats or between valve seat inserts and the spark plug thread can be used further without reducing service life, provided the cracks do not exceed a maximum of 0.3 mm in width, or when no more than the first 4 turns of the spark plug threads are cracked.*
- ◆ *After installing new lifters the engine must not be started for about 30 minutes (otherwise valves will strike pistons). Turn crankshaft two complete revolutions before starting.*
- ◆ *Carefully apply a small amount of sealant D 454 300 A2 at the four end points of the sealing surfaces on the cylinder head, using a small screwdriver ⇒ Fig. ⇒ [1](#).*

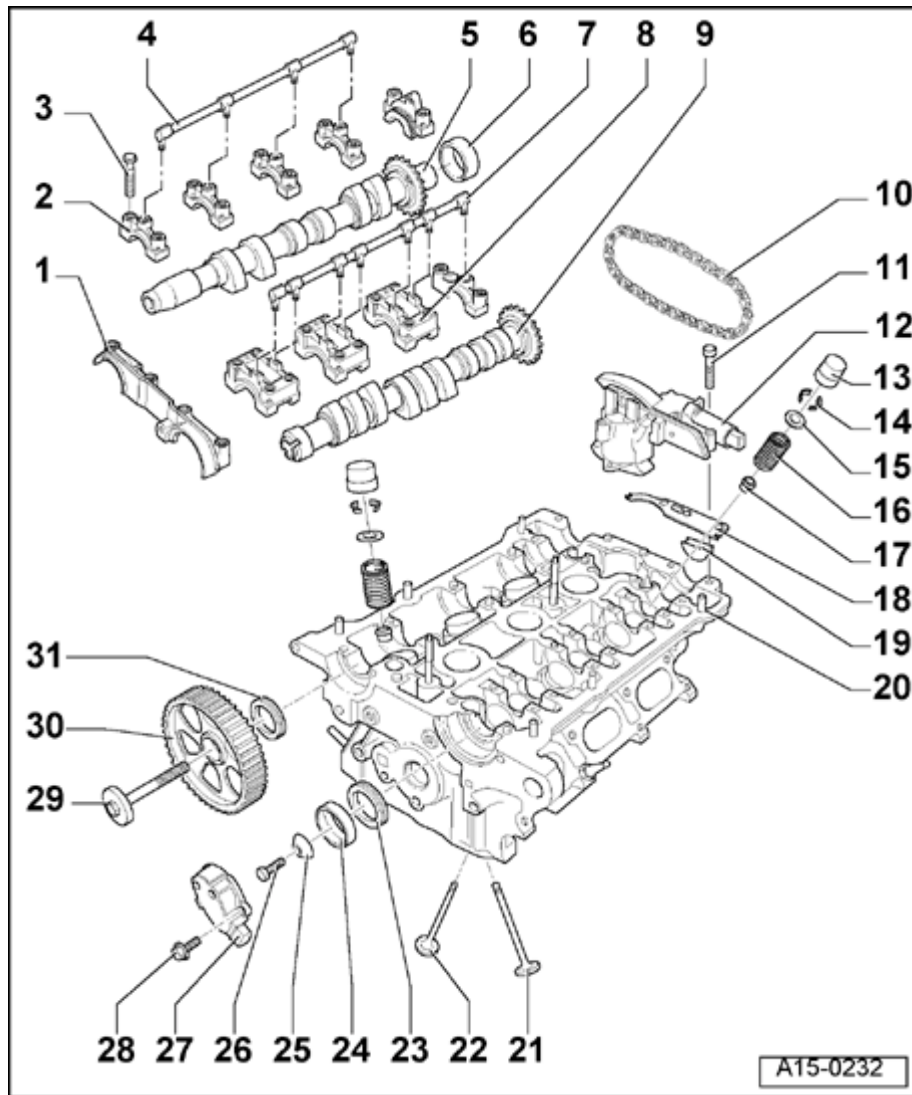

1 - Double bearing cap

- ◆ Lightly coat with sealant 454 300 A2 before installing ⇒ from Page ⇒ [Page 15-16](#)

2 - Exhaust camshaft bearing cap

- ◆ With connection for oil feed line
- ◆ Watch position of dowel sleeve
- ◆ Note installation position and numbering ⇒ [Page 15-75](#)
- ◆ Lightly coat last bearing cap (after the chain) with sealant D 454 300 A2 before installing

3 - 10 Nm

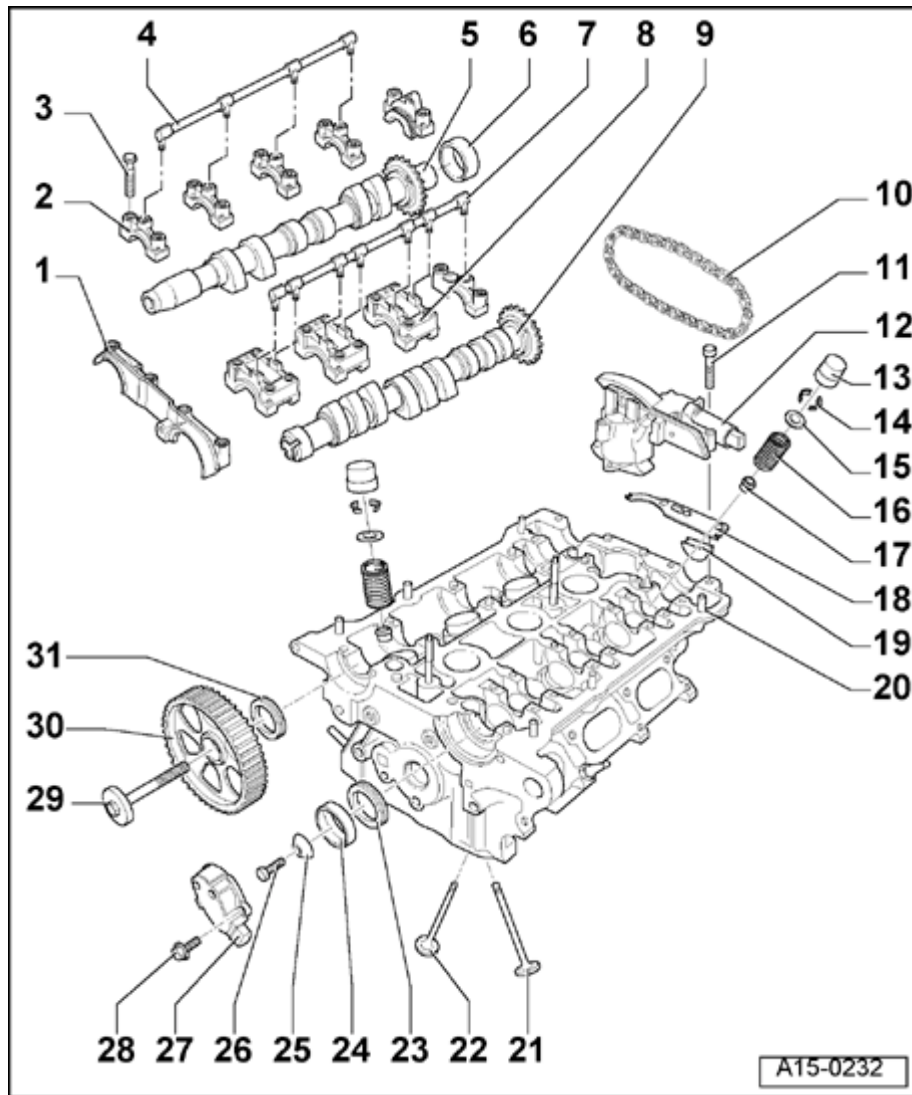

4 - Oil line outlet side

- ◆ For lubricating bearing cap
- ◆ Note installation position ⇒ Fig. ⇒ [3](#)

5 - Exhaust camshaft

- ◆ Checking axial clearance ⇒ [Page 15-86](#)
- ◆ Removing and installing ⇒ [Page 15-75](#)
- ◆ Check radial clearance with Plastigage (lifters removed) Wear limit: 0.1 mm Run-out: 0.01 mm (maximum)

6 - Cap

- ◆ Always replace

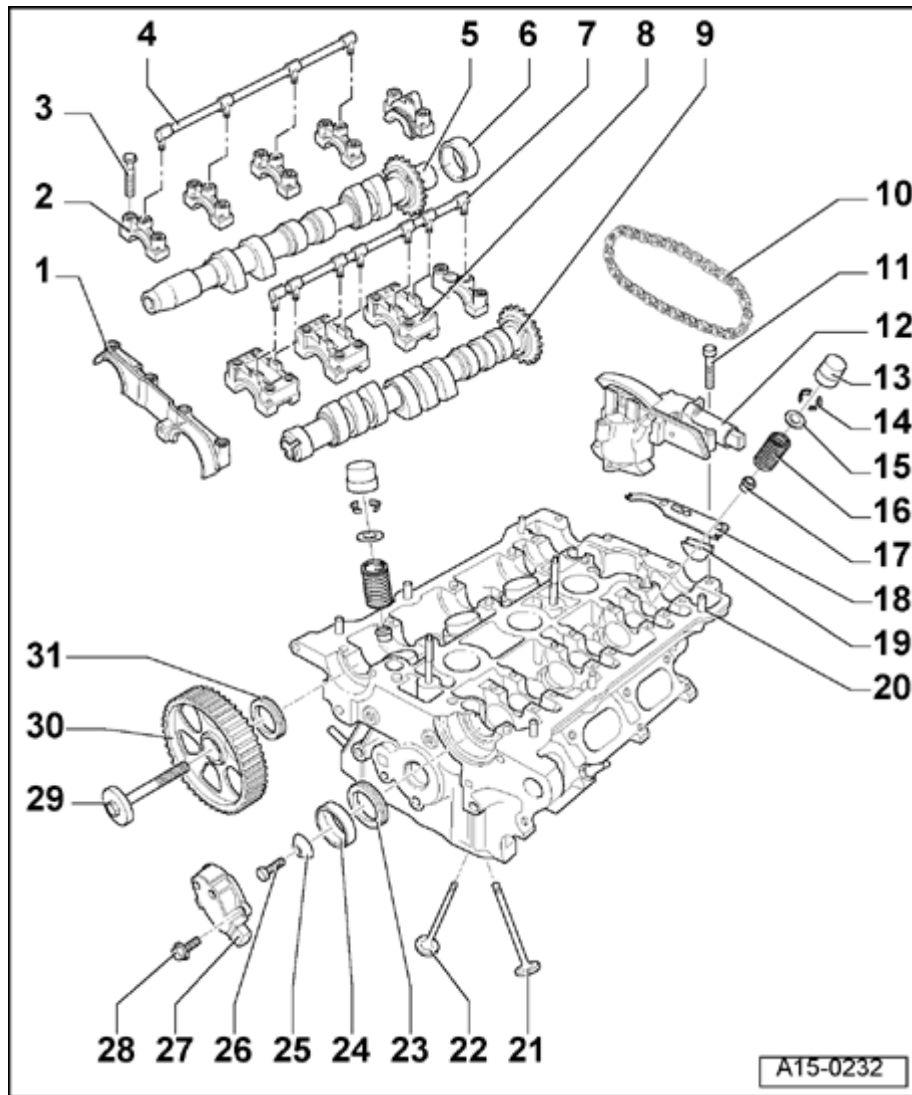

7 - Oil line, inlet side

- ◆ Note installation position ⇒ Fig. ⇒ [2](#)
- ◆ For lubricating bearing cap

8 - Inlet camshaft bearing cap

- ◆ With connection for oil feed line
- ◆ Note installation position and numbering ⇒ [Page 15-75](#)

9 - Inlet camshaft

- ◆ Checking axial clearance ⇒ [Page 15-86](#)
- ◆ Removing and installing ⇒ [Page 15-75](#)
- ◆ Check radial clearance with Plastigage (lifters removed) Wear limit: 0.1 mm Run-out: 0.01 mm (maximum)

10 - Drive chain

- ◆ Installing ⇒ [Page 15-75](#)

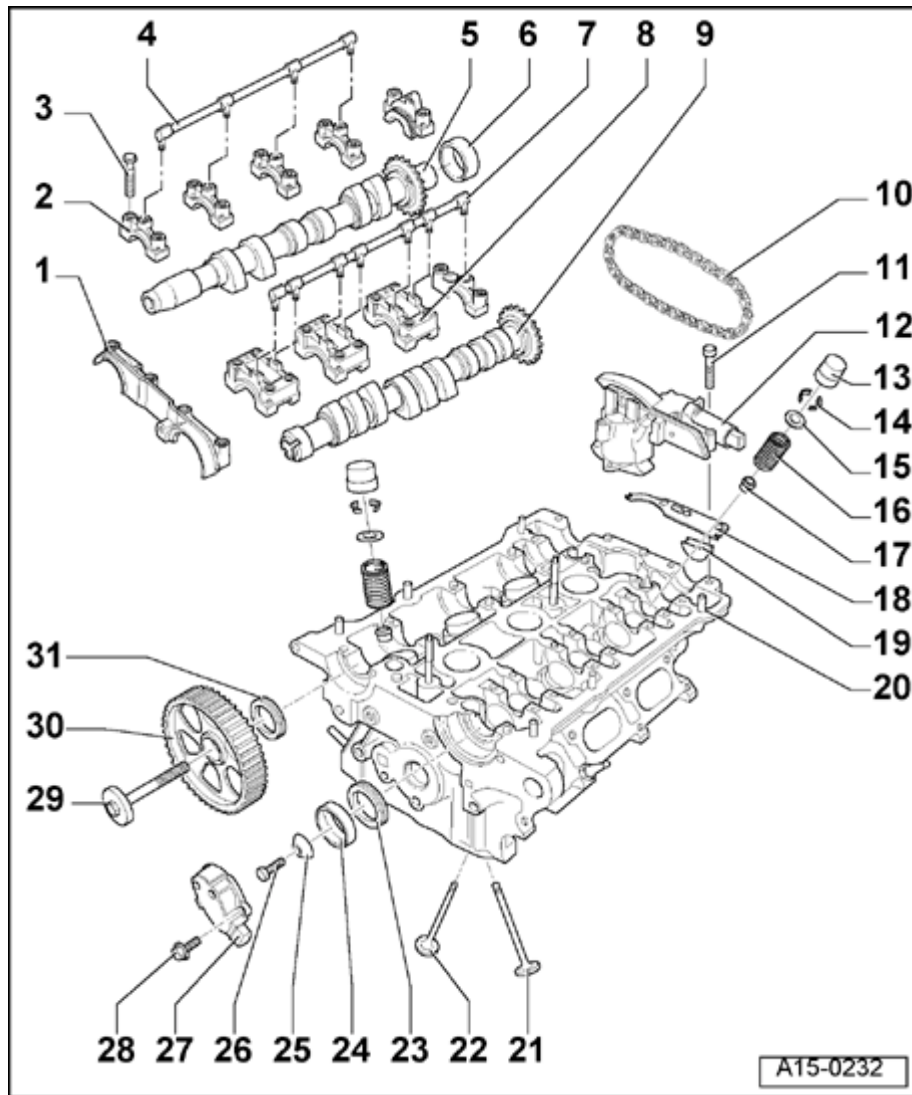

11 - 10 Nm

12 - Mechanical camshaft adjuster

- ◆ With camshaft adjustment valve -N205
- ◆ Secure with special tool 3366 before removing ⇒ [Page 15-75](#)

13 - Hydraulic lifter

- ◆ Notes ⇒ [Page 15-88](#)
- ◆ Removing and installing with cylinder head installed ⇒ [Page 15-75](#)

14 - Valve cotter

15 - Valve spring plate

16 - Valve spring

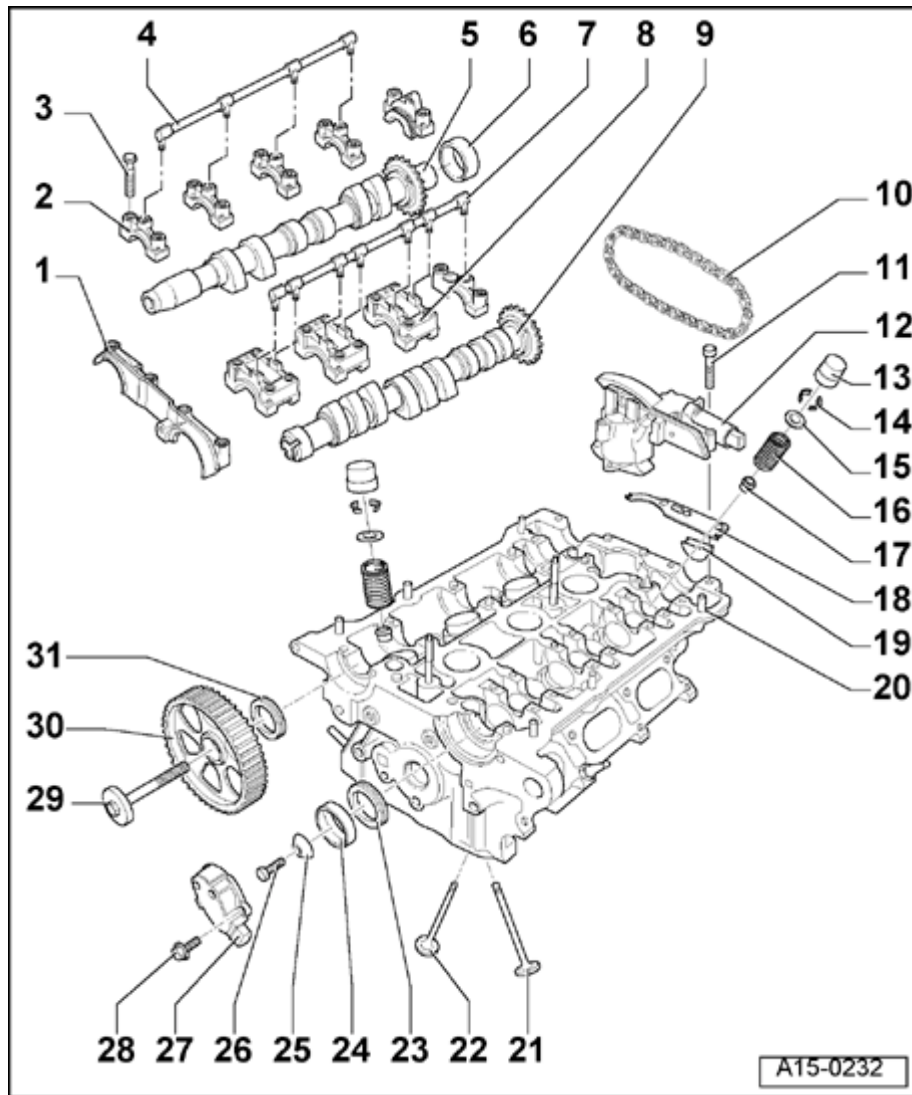
**17 - Valve stem seal**

- ◆ Replacing with cylinder head installed ⇒ [Page 15-90](#)

18 - Rubber/metal gasket

- ◆ Always replace

19 - Seal

- ◆ Always replace

20 - Cylinder head

- ◆ Checking for distortion ⇒ [Page 15-56](#)
- ◆ Reworking ⇒ [Page 15-57](#)

21 - Exhaust valve**22 - Inlet valve****23 - Oil seal (Hall sensor end)**

- ◆ Always replace ⇒ [Page 15-10](#)

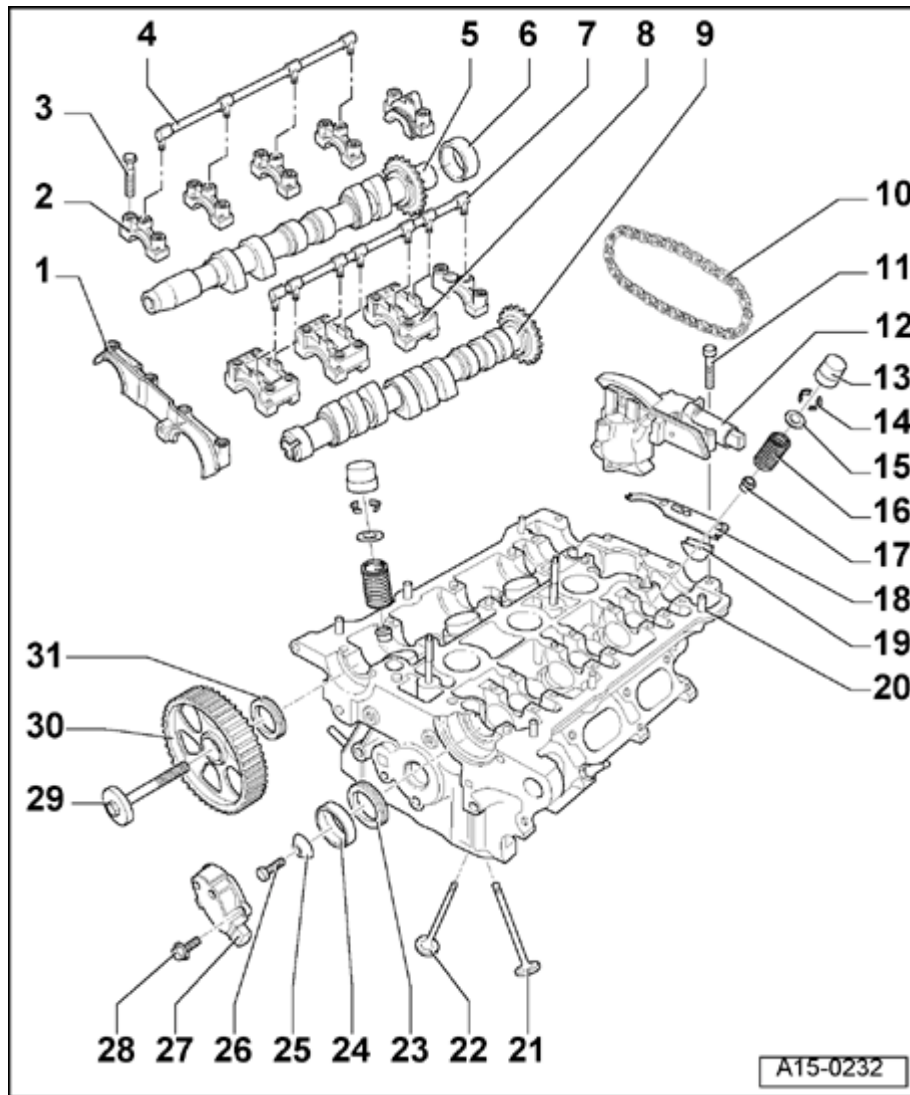

24 - Rotor for Hall sensor

- ◆ Note position (notch on camshaft)

25 - Washer

- ◆ Conical

26 - 25 Nm

27 - Hall sensor

28 - 10 Nm

29 - 30 Nm +180° (1/2 turn)

30 - Camshaft sprocket

31 - Oil seal (toothed belt end)

- ◆ Replacing ⇒ [Page 15-10](#)

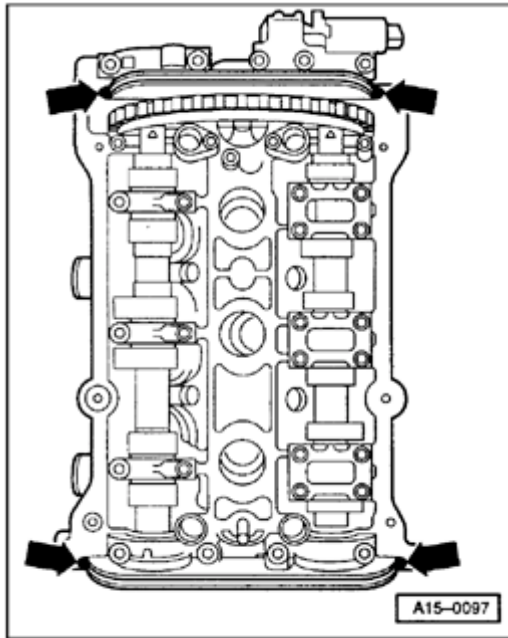

A

Fig. 1 Sealing end points of joints between bearing caps and cylinder head

Carefully apply a small quantity of sealant D 454 300 A2 at the four end points of the sealing surfaces on the cylinder head -arrows-, using a small screwdriver.

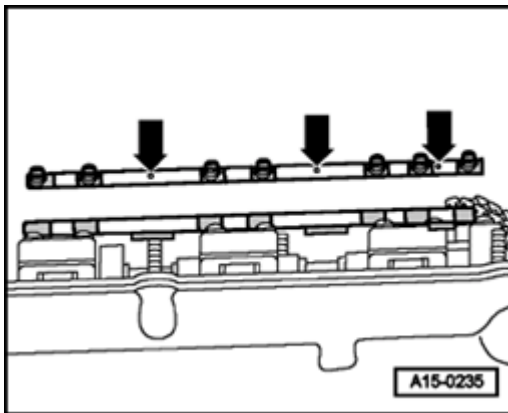

A

Fig. 2 Installation position of the oil line for the inlet camshaft

When connections are incorrectly allocated, bore holes in the oil line are exposed (arrows).

To mount correctly, turn the oil line 180° and slide connections over bore holes.

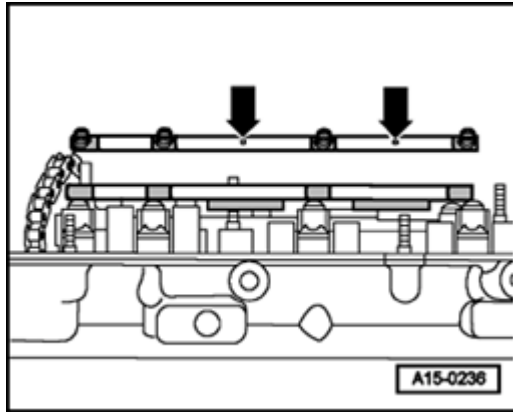

A

Fig. 3 Installation position of the oil line for the outlet camshaft

When connections are incorrectly allocated, bore holes in the oil line are exposed (arrows).

To mount correctly, turn the oil line 180° and slide connections over bore holes.

CAUTION!

If the oil lines are mounted incorrectly, lubrication of the camshaft bearing is no longer possible and the cylinder head must be replaced.

Oil seals in cylinder heads, replacing

Oil seal for camshaft drive (left and right cylinder heads)

Note:

If the oil seal on one side is leaking it is advisable to replace the seals on both sides.

- Remove ribbed belt ⇒ [Page 13-1](#) .

- Remove toothed belt ⇒ [Page 13-4](#) .

- Remove rear toothed belt guard.

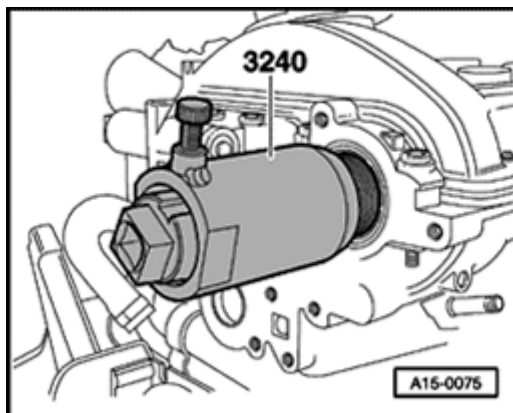

A

- Pull out oil seal with oil seal extractor 3240.
- Clean contact surface and sealing surface.
- Do not apply oil to sealing lip or outer circumference of seal.
- Install guide sleeve 3241/2 (from tool set 3241) onto camshaft.



A

- Press seal flush into cylinder head using press sleeve 3241/1 and bolt 3241/3.

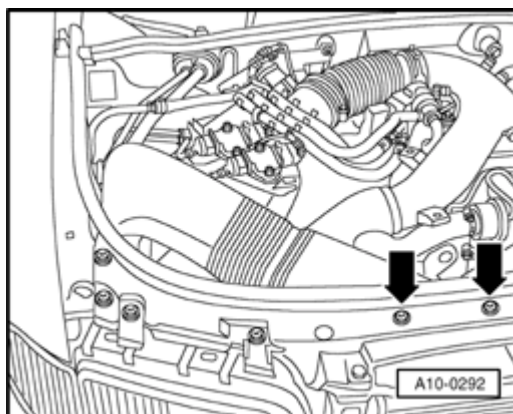
Oil seal at Hall sensor (right cylinder head)

- A**
- Remove intake hose going to air cleaner (arrows).

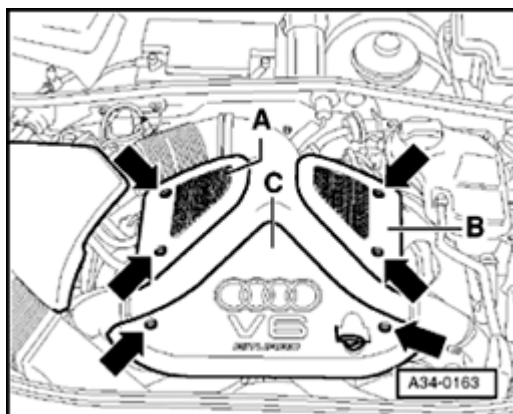

- A**
- Remove bolts -arrows- and remove engine cover panel -C-.

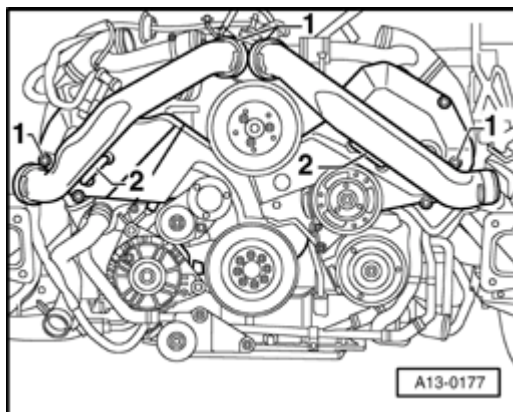

- A**
- Remove pressure line -1- (right side).

Note:

Watch position of retaining strip -2-.

- Unbolt Hall sensor housing (10 Nm).
- Remove bolt securing Hall sensor rotor (20 Nm) and carefully lever off rotor with a screwdriver.

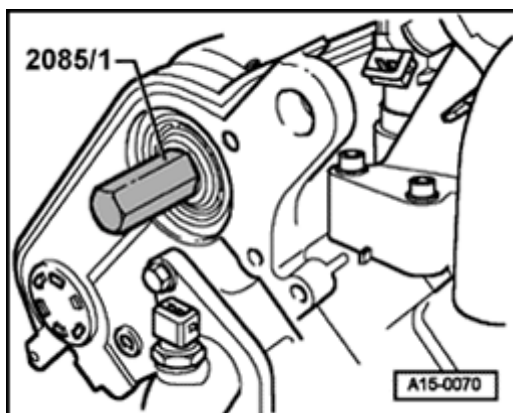

- A**
- Screw in bolt from oil seal extractor 2085/1.

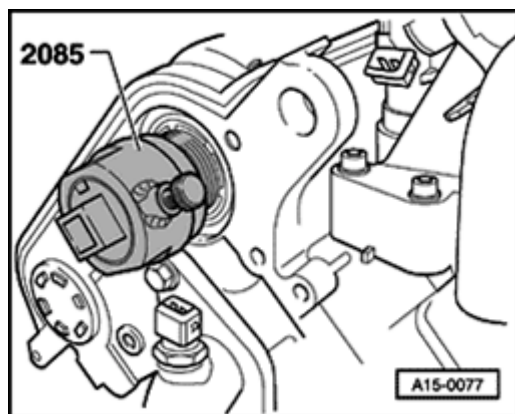

- A**
- Pull out seal with oil seal extractor 2085 and bolt 2085/1.
 - Clean contact surface and sealing surface.
- Do not apply oil to sealing lip or outer circumference of seal before installing.
- Install guide sleeve (from tool set 3241) onto camshaft.

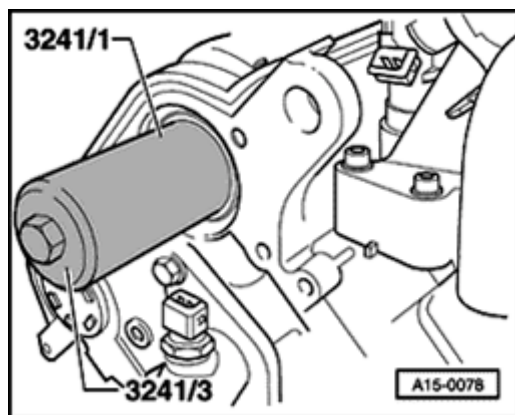

- A**
- Press in seal until flush using press sleeve 3241/1 and bolt 3241/3.

Installing

Install in reverse sequence.

Note:

When installing Hall sensor rotor, ensure that locating lug engages in slot in camshaft.

Removing oil seal at Hall sensor (left cylinder head)

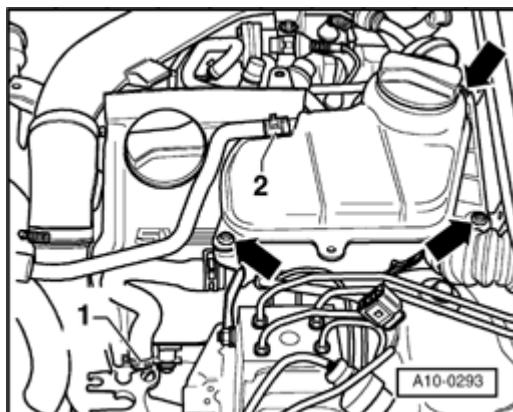

- A**
- Detach coolant reservoir -arrows- and move clear to side.

Note:

Leave coolant hoses connected.

- Unplug connector from coolant level monitor.
- Move wiring harness clear at bulkhead.

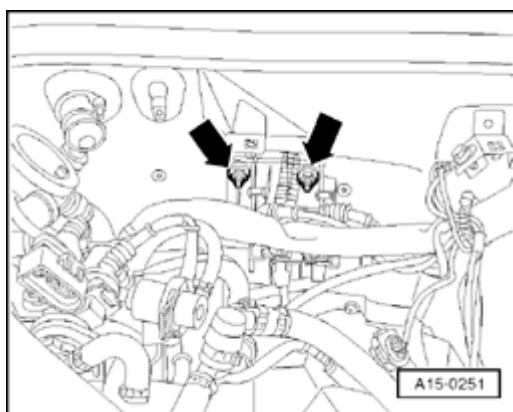

- A**
- Unbolt bracket -arrows- for plug connectors on bulkhead and move clear to side.

- Unbolt Hall sensor housing (10 Nm).
- Unbolt Hall sensor rotor (20 Nm) and carefully lever off rotor using a screwdriver.

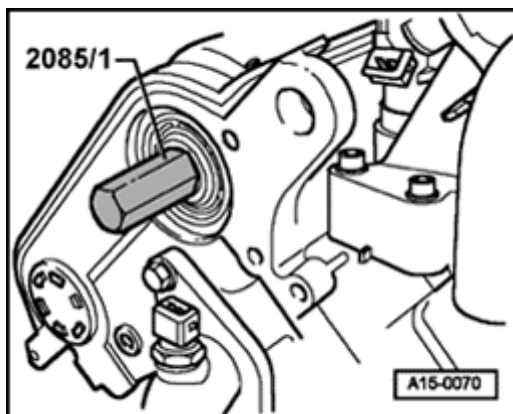

A

- Screw in bolt from 2085/1 oil ring extractor.

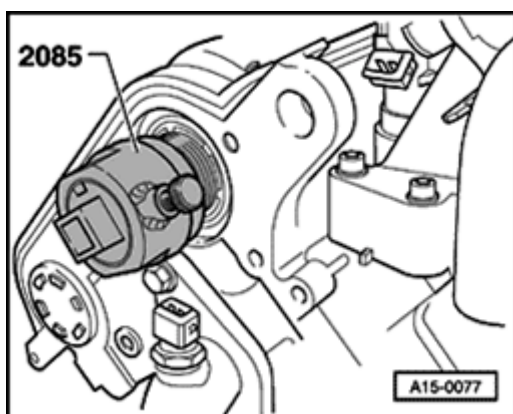

A

- Pull out seal with oil seal extractor 2085 and bolt 2085/1.
- Clean contact surface and sealing surface.
Do not apply oil to sealing lip or outer circumference of seal before installing.
- install guide sleeve (from tool set 3241) onto camshaft.

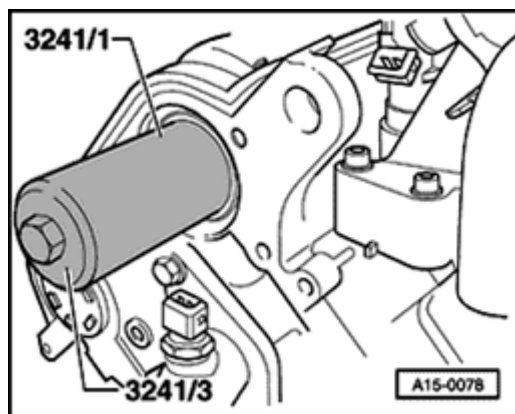

A

- Press in seal until flush using press sleeve 3241/1 and bolt 3241/3.

Installing

Install in reverse sequence.

Note:

When installing Hall sensor rotor, ensure that locating lug engages in slot in camshaft.

Rear oil seal and sealing flange (left cylinder head)

Note:

Rear sealing flange and oil seal on left-hand cylinder head must be replaced together as follows:

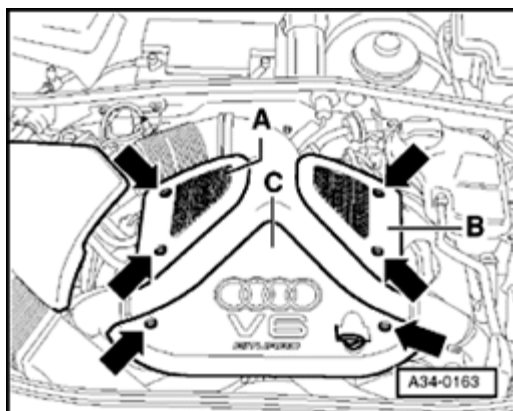

- A** - Remove bolts -arrows- and remove engine cover panels -A...C-.

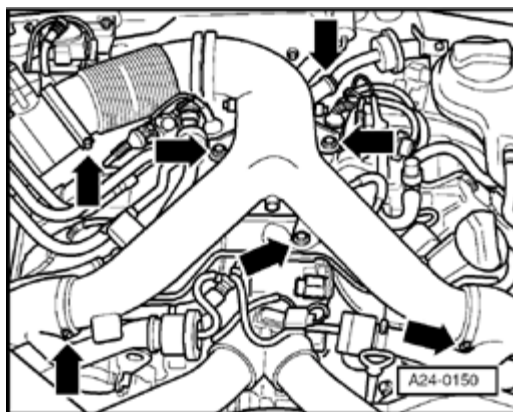

- A** - Remove air duct -arrows-.

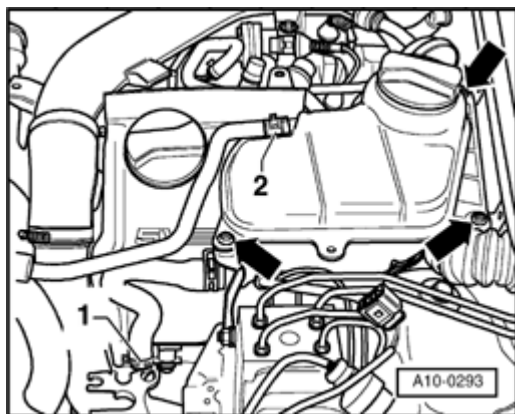

- A**
- Remove coolant reservoir -arrows- and move it clear to the side.

Note:

Leave coolant hoses connected.

- Unplug connector from coolant level monitor.
- Move wiring harness clear at bulkhead.

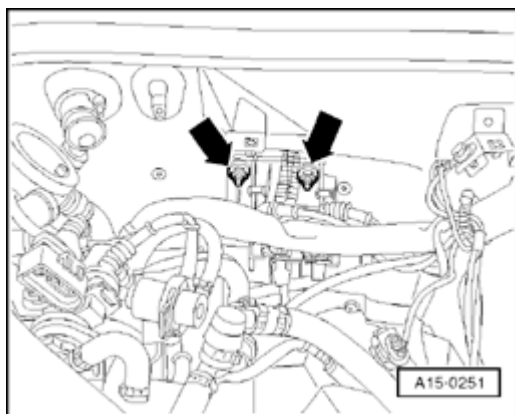

- A**
- Unbolt bracket -arrows- for plug connectors on bulkhead and move clear to the side.
 - Unbolt Hall sensor housing (10 Nm).
 - Remove bolt securing Hall sensor rotor (20 Nm) and carefully lever off rotor using a screwdriver.



- Remove cover panel from cylinder head cover (cylinder bank 4-6).

A

- Release hose clamp -arrow-.
- Remove upper section of intake line -1-.
- Disconnect hose -2-.

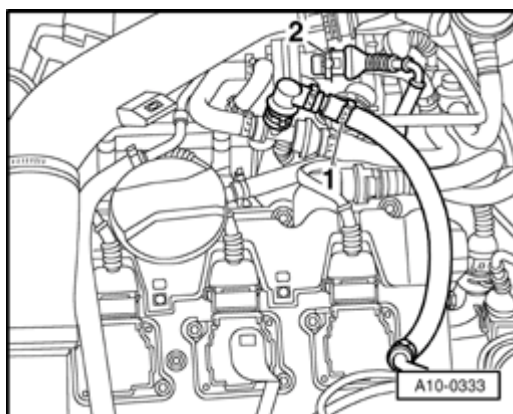

- Disconnect hose (arrow).
- Remove bolt securing toothed belt guard from cylinder head cover.
- Pull plug connectors off ignition coils.
- Pull crankcase breather off cylinder head cover.
- Remove cylinder head cover.

A

15-20

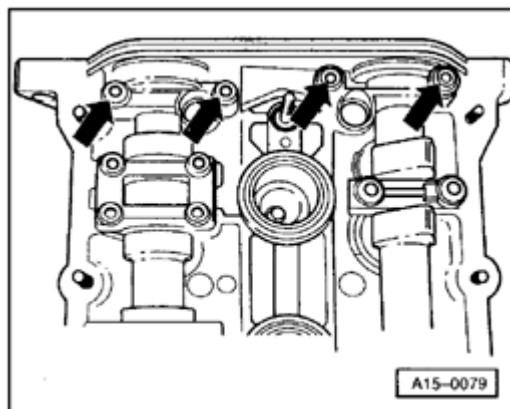

A

- Remove double bearing cap -arrows-.
- Take out oil seal and sealing flange.
- Clean contact surfaces and sealing surfaces of double bearing cap.

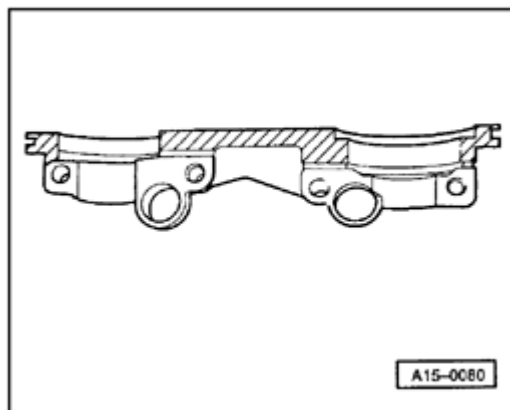

A

- Apply a thin coating of sealant 454 300 A2 to shaded areas on double bearing cap (see illustration), install bearing cap and tighten bolts to 10 Nm.

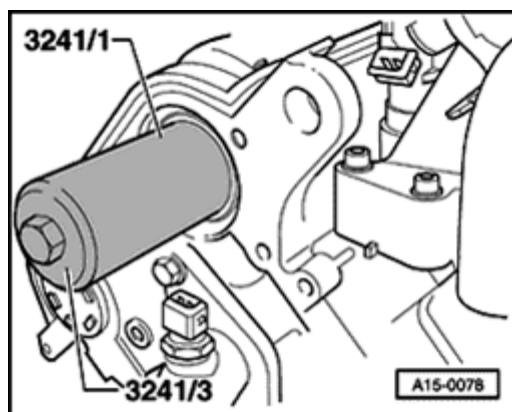

A

- Install guide sleeve (from tool set 3241) onto camshaft.
- Press in oil seal until flush using press sleeve 3241/1 and bolt 3241/3.
- Carefully knock in sealing flange against stop using 3202 and a plastic hammer.

Installing

Install in reverse sequence; note the following points:

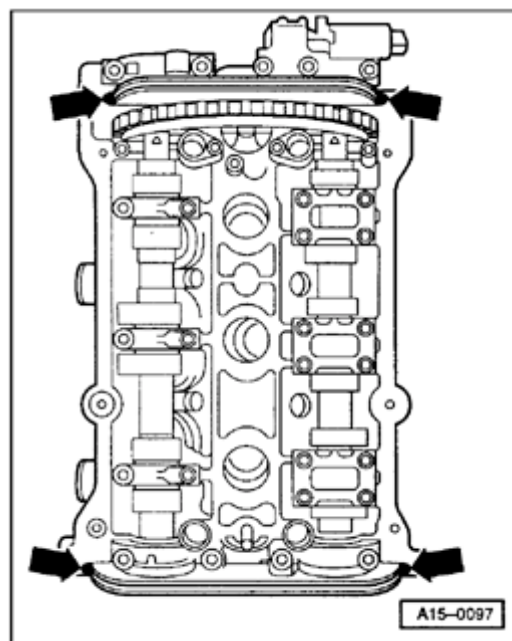

A

- Seal end points of joints between bearing caps and cylinder head.
- Before installing cylinder head cover and gasket, carefully apply a small quantity of sealant D 454 300 A2 at four end points of sealing surfaces on cylinder head -arrows-, using a small screwdriver.

Cylinder head covers, removing and installing

Removing and installing left cylinder head cover

Removing

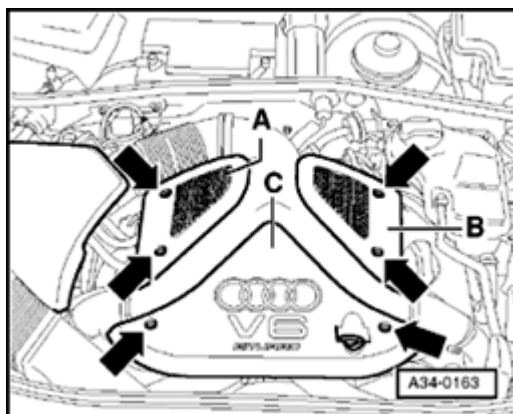

- A** - Remove bolts -arrows- and remove engine cover panels -A...C-.

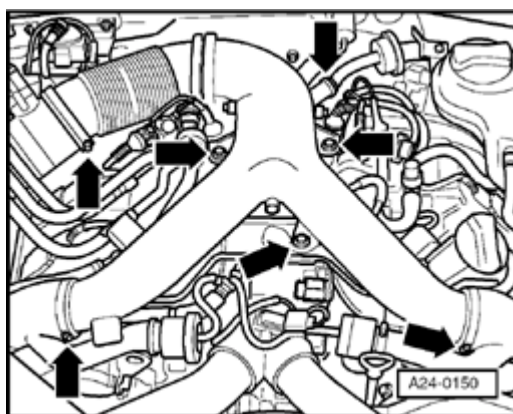

- A** - Remove air duct -arrows-.

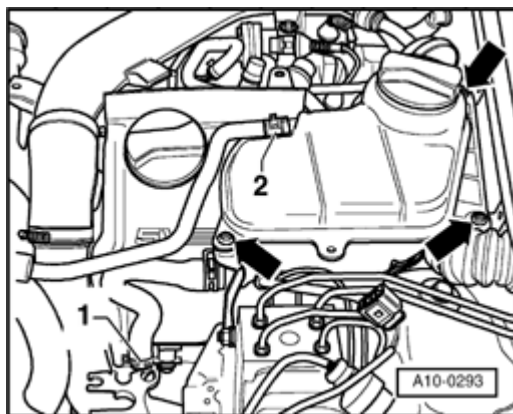

- A**
- Remove coolant reservoir -arrows- and move it clear to the side.

Note:

Leave coolant hoses connected.

- Unplug connector from coolant level monitor.
- Remove cover panel from cylinder head cover (cylinder bank 4 - 6).



- A**
- Release hose clamp -arrow-.
 - Remove intake line -1-.
 - Disconnect hose -2-.
 - Detach water line -3-.

Note:

Plug lower section of intake line.

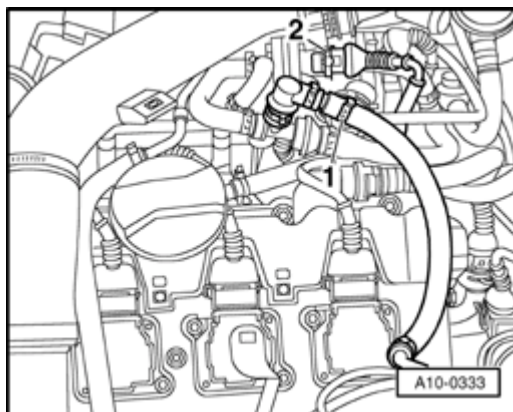

- A**
- Pull off hose -1-.
 - Pull plug connectors off ignition coils.
 - Pull crankcase breather off cylinder head cover.
 - Remove ignition coils.
 - Remove cylinder head cover.

Installing

Install in reverse sequence; note the following points:

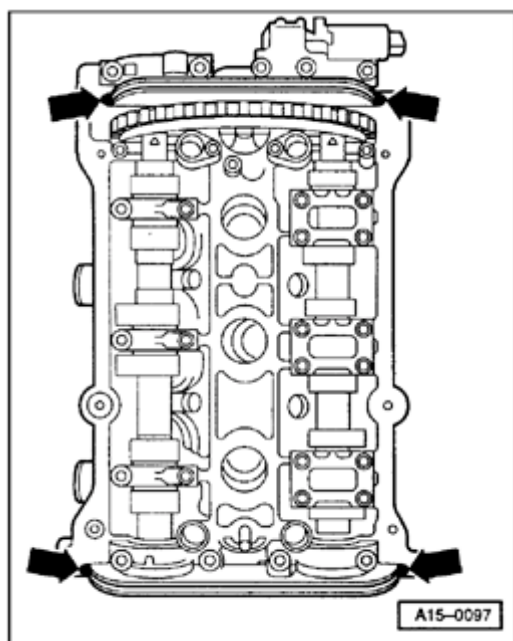

- A**
- Seal end points of joints between bearing caps and cylinder head.
 - Before installing cylinder head cover and gasket, carefully apply a small quantity of sealant D 454 300 A2 at four end points of sealing surfaces on cylinder head -arrows-, using a small screwdriver.

Removing and installing right cylinder head cover

Removing

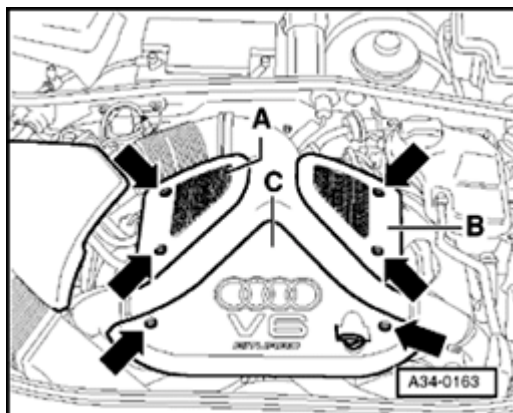

- A**
- Remove bolts -arrows- and remove engine cover panels -A...C-.
 - Remove cover above air cleaner.

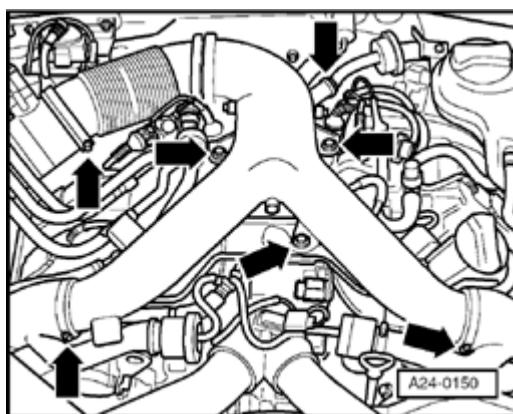

- A**
- Remove air duct -arrows-.

WARNING!

Fuel system is under pressure. Before opening the system, place a cloth around the connection. Then release pressure by carefully loosening the connection.

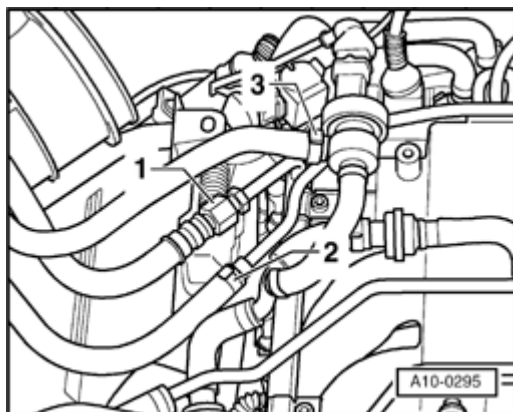

A

- Disconnect fuel supply line and fuel return line -1- and -2-, and move fuel lines clear.
- Pull hose off EVAP valve -3-.

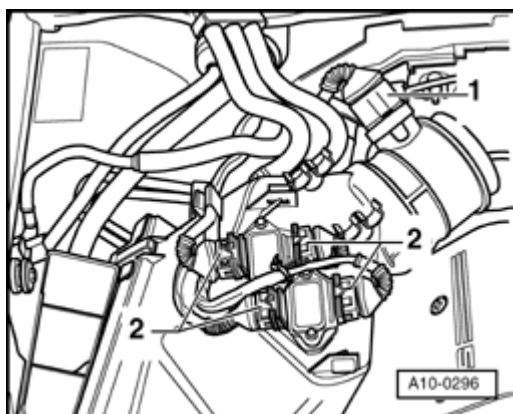

A

- Unplug connector -1- from air mass meter.
- Unplug connectors -2- from ignition output stages, and move wiring clear.
- Remove air cleaner.

15-27

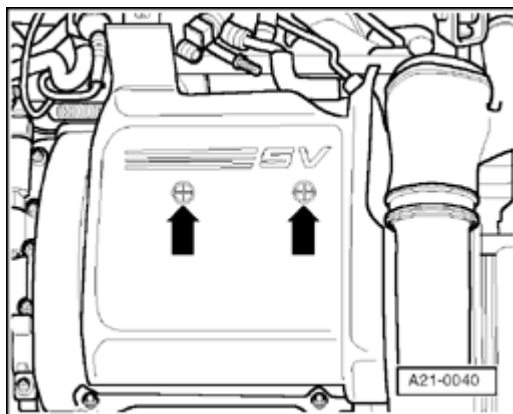

- A**
- Remove cover panel from right-hand cylinder head cover -arrows-.

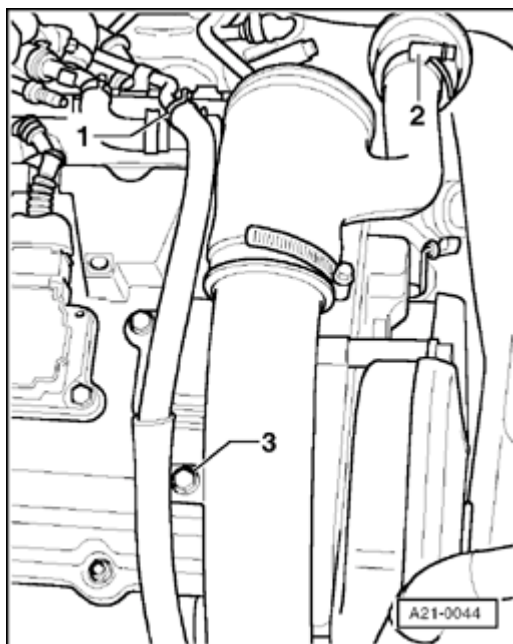

- A**
- Disconnect hose -1-.
 - Disconnect hose -2-.
 - Detach upper section of intake line -3-.

Note:

Plug lower section of intake line.

- Remove bolt securing toothed belt guard from cylinder head cover.
- Unplug connectors from ignition coils.
- Pull crankcase breather off cylinder head cover.
- Remove ignition coils.
- Remove cylinder head cover.

Installing

Install in reverse sequence; note the following points.

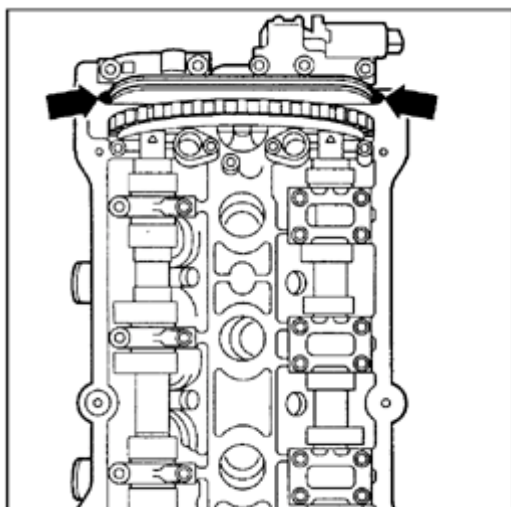

A

- Seal end points of joints between bearing caps and cylinder head.
- Before installing cylinder head cover and gasket, carefully apply a small quantity of sealant D 454 300 A2 at four end points of sealing surfaces on cylinder head -arrows-, using a small screwdriver.

Cylinder head, removing and installing

Removing and installing left cylinder head

Notes:

- ◆ All hose connections are secured with clips.
- ◆ Charge air system must be free of leaks.
- ◆ Replace all seals and gaskets

Removing

- Remove engine ⇒ [Page 10-1](#) .
- A - Unplug connector from air recirculation valve -2-.

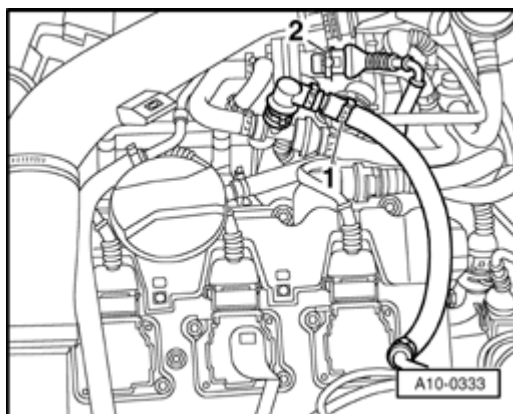

15-30

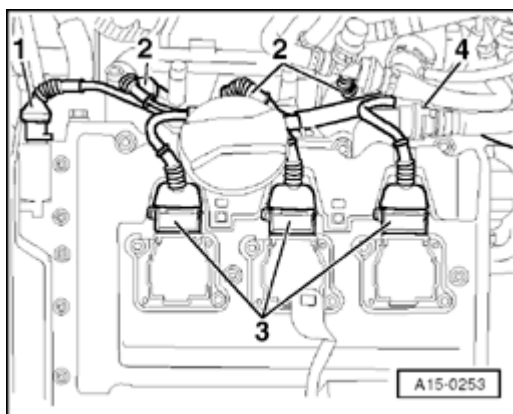

- A**
- Unplug connector for camshaft timing control -1- (cylinder bank 4..6).
 - Unplug connectors from injectors -2- (cylinder bank 4..6).
 - Unplug connectors from ignition coils -3- and move wiring harness clear (cylinder bank 4..6).
 - Pull crankcase breather -4- off cylinder head cover (cylinder bank 4..6).
 - Remove ignition coils.

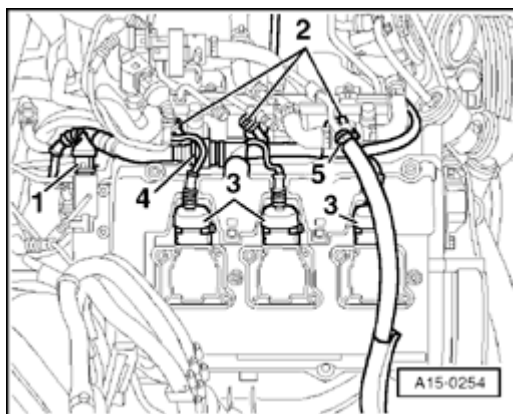

- A**
- Unplug connectors from injectors -2- (cylinder bank 1..3).
 - Pull off hose -5- going to turbocharger intake side.

15-31

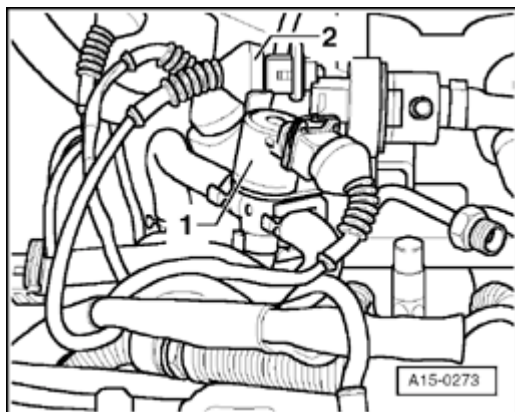

- A**
- Unclip solenoid valve for charge pressure control -1-.
 - Pull connector off EVAP valve -2-.

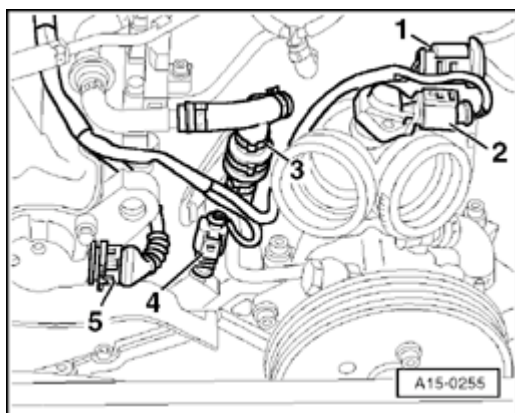

- A**
- Pull connector off throttle unit -1-.
 - Pull connector off charge air sensor -2-.
 - Pull off crankcase breather -3-.
 - Pull connector off intake air temperature sensor -4-.

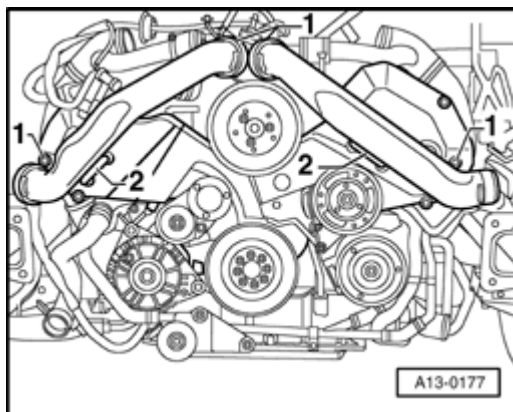

- A**
- Remove pressure lines -1-.

Note:

Watch position of retaining strips -2-.

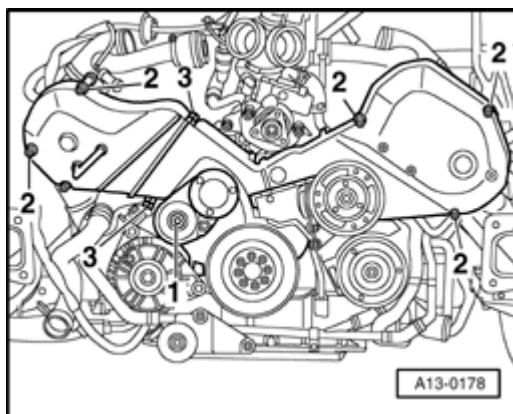

- A**
- Remove tensioner -1- for ribbed belt.
 - Remove toothed belt guards -2- (left and right).
 - Remove toothed belt guard -3- (center).

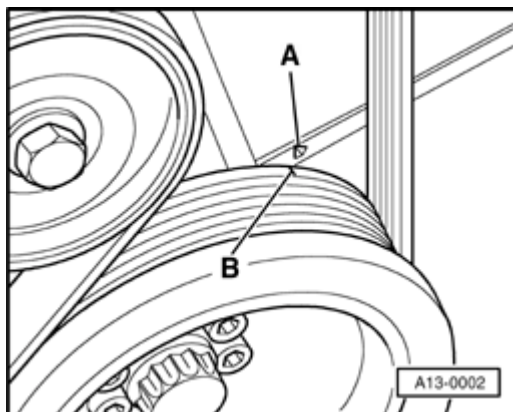

- A**
- Turn crankshaft to TDC by hand. Marks -A- and -B- must be aligned.

Note:

Turn over the engine at the central bolt on the crankshaft.

- Check position of camshafts: larger holes in securing plates on camshaft sprockets must align opposite one another on inside. If this is not the case, turn crankshaft one revolution further.
- Remove sealing plug from cylinder block, left.
TDC drilling in the crankshaft must be visible (or able to be felt) in line with the sealing plug hole.

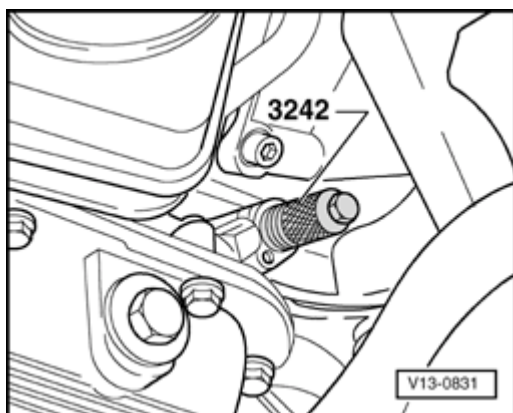

- A**
- Screw clamping bolt 3242 for crankshaft into sealing plug hole and tighten.

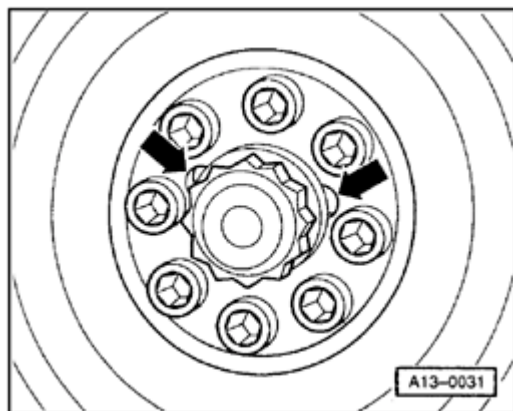

- A** - Remove vibration damper on crankshaft.

Note:

The central bolt does not have to be loosened to remove the vibration damper.

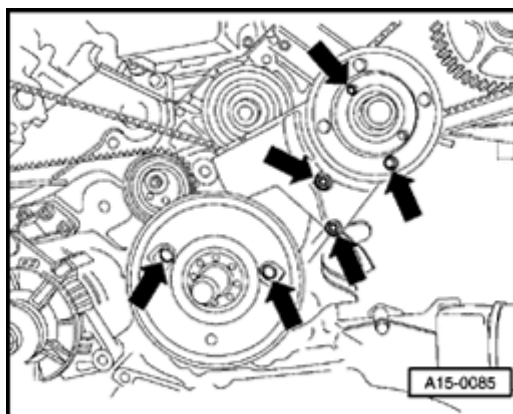

- A**
- Remove idler wheel for ribbed belt -arrows-.
 - Remove toothed belt guard behind vibration damper -arrows-.

Notes:

- ◆ *Mark the direction of rotation of the toothed belt with chalk or felt pen before removing. A used belt can break if it rotates in the wrong direction when reinstalled.*
- ◆ *The toothed belt tensioning element is oil-damped and can therefore only be compressed slowly by applying constant pressure.*

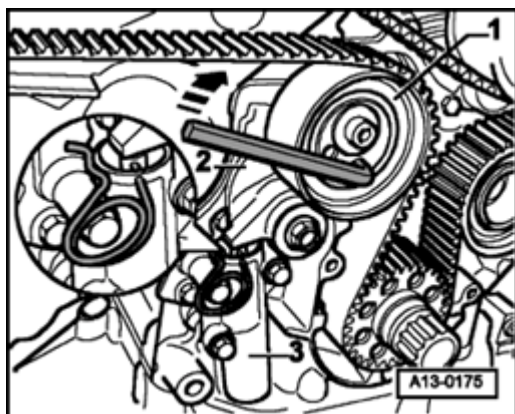

- A
- Using a hexagon key, turn toothed belt tensioning roller -1- clockwise 8 mm in direction of arrow until tensioning lever -2- compresses tensioning element -3- sufficiently to enable a 2mm dia. spring pin to be installed in the drilling and in the plunger.
 - Insert spring pin and release toothed belt tensioning roller.
Use spring pin from 2024 A.
 - Insert camshaft clamp 3391 in securing plates of two camshafts.
 - Loosen both camshaft bolts and remove approx. 5 turns.
 - Take out camshaft clamp 3391.

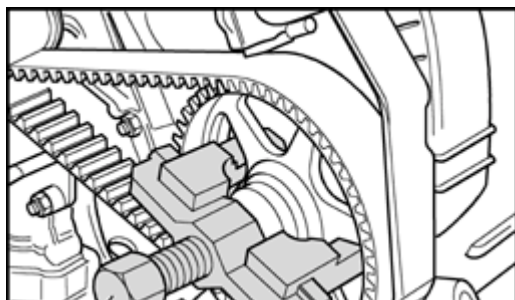

- A
- Pull off both camshaft sprockets with special tool T40001.

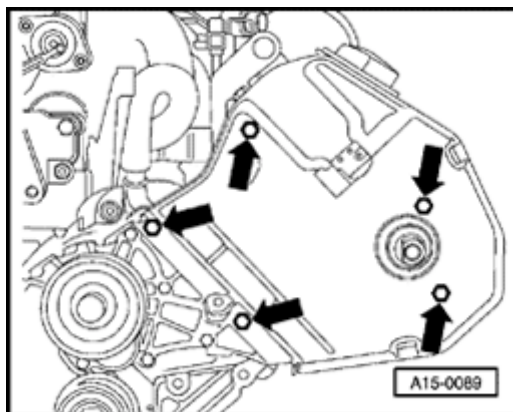

- A**
- Unbolt rear left toothed belt guard -arrows-.
 - Detach intake manifold using special tool 3249.

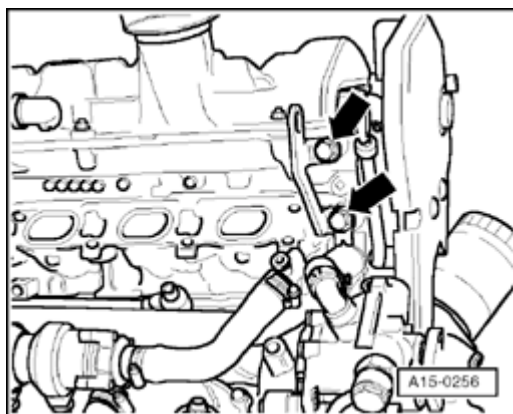

- A**
- Unbolt cylinder head lifting bracket with coolant line -arrows- from cylinder head.

15-37

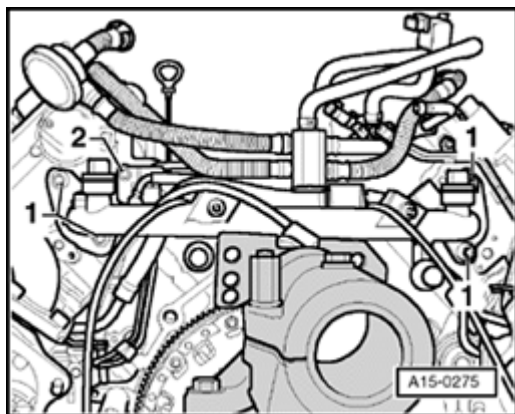

- A**
- Unbolt water line -1- and pull it towards the rear.
 - Unbolt bracket -2- from cylinder head.
 - Remove heat sensor -2-.

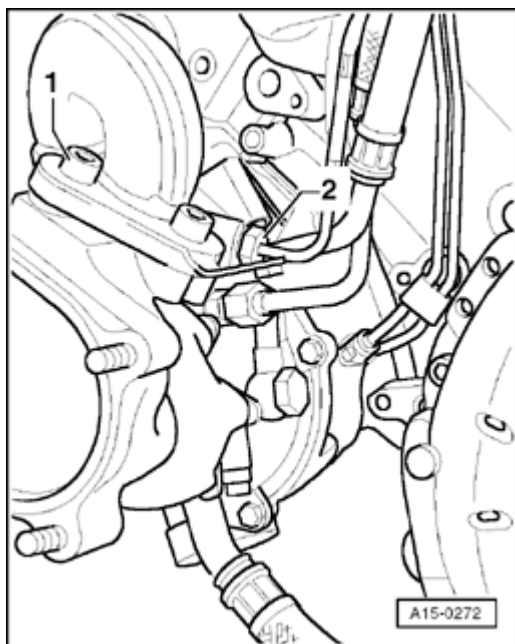

- A**
- Unbolt turbocharger -1- from exhaust manifold (3 bolts).

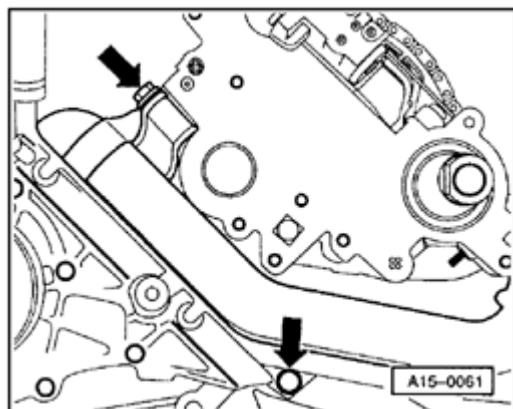

- A**
- Unbolt coolant line at front of cylinder head -arrows-.
 - Unbolt cylinder head cover.
 - Loosen and remove cylinder head bolts in opposite sequence to tightening sequence using special tool 3452 (Polidrive).
 - Carefully lift off cylinder head.

Note:

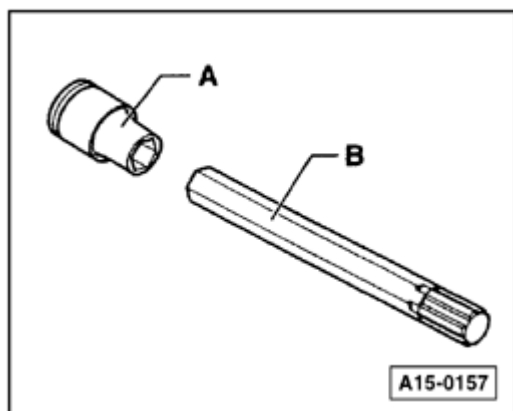

- A**
- Use special tool 3452 together with a normal commercial 10 mm socket when removing and installing.*

Installing

Notes:

- ◆ *Do not allow any oil or coolant to remain in the blind holes for the cylinder head bolts in the cylinder block.*
- ◆ *Replace cylinder head bolts.*
- ◆ *Connecting vacuum hoses ⇒ [Page 10-28](#) .*

When installing a new cylinder head:

- Screw in centering pin for intake manifold.

The cylinder head supplied as a replacement part can be used on both sides (left or right). But a sealing cap (core plug) must be installed in the front end of the cylinder head in each case.

- Coat outside circumference of sealing cap (core plug) with sealant AMV 188 001 02.

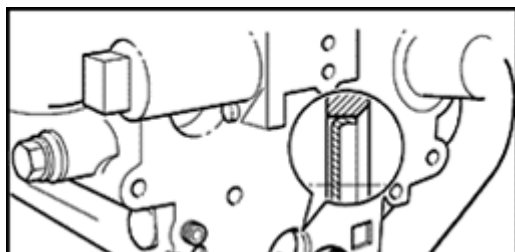

A

- Using drift VW 295, knock in sealing cap (core plug) until outside rim is flush with end of chamfer in cylinder head.

- Before installing cylinder head in position, turn crankshaft and camshafts to TDC of No. 3 cylinder.
- Install cylinder head gasket on dowel sleeves. The marking "oben" (top) or part number must face towards cylinder head.
- Install cylinder head, insert cylinder head bolts and tighten finger-tight.

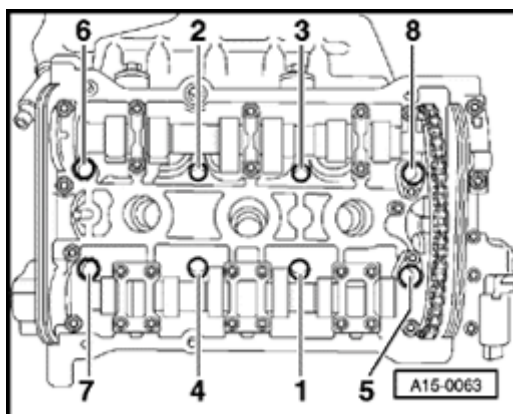

A

- Tighten cylinder head bolts in two stages in sequence shown, as follows:
 - ◆ Stage 1 = 60 Nm.
 - ◆ Stage 2 = turn a further $1/2$ turn (180°) with a rigid wrench (turning $2 \times 90^\circ$ is also permissible).

It is not necessary to torque down cylinder head bolts again after repairs have been completed.

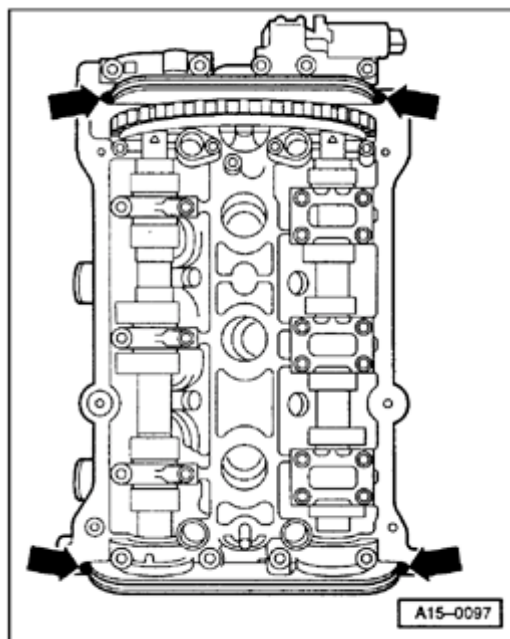

A

- Seal end points of joints between bearing caps and cylinder head.
- Before installing cylinder head cover and gasket, carefully apply a small quantity of sealant D 454 300 A2 at four end points of sealing surfaces on cylinder head -arrows-, using a small screwdriver.

Tightening torques

Component		Nm
Bolts	M6	10
Bolts	M8	20
Camshaft bearing caps and camshaft adjuster		10
Exhaust manifold to cylinder head		25
Front exhaust pipe to exhaust manifold		25
Oxygen sensor		50
Spark plugs		25
Toothed belt sprocket to camshaft		55
Intake manifold to cylinder head		10
Cylinder head cover		10

Removing and installing right cylinder head

Notes:

- ◆ *All hose connections are secured with clips.*
- ◆ *Charge air system must be free of leaks.*
- ◆ *Replace all seals and gaskets*

Removing

- Remove engine ⇒ [Page 10-1](#) .
- Unplug connector from air recirculation valve -2-.

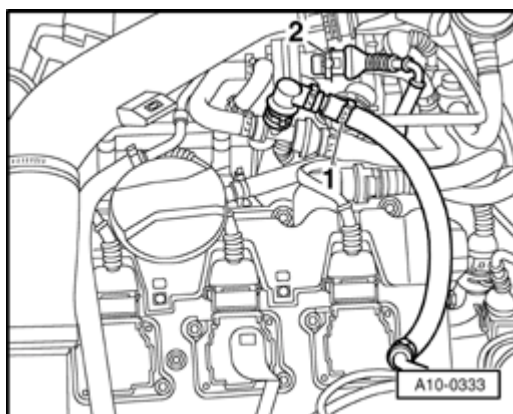

A

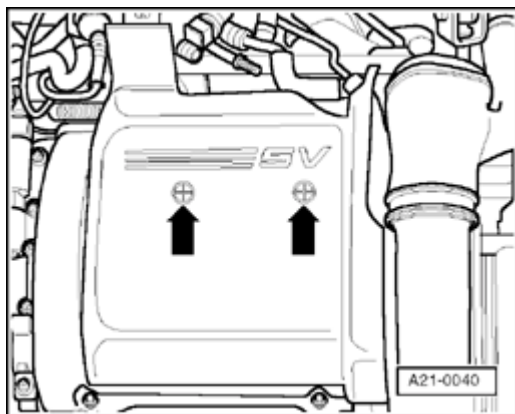

- A**
- Remove cover panel from right-hand cylinder head cover -arrows-.

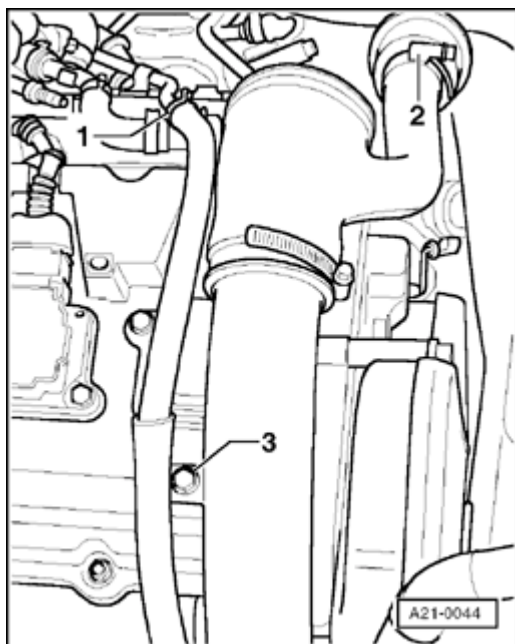

- A**
- Disconnect hose -1-.
 - Disconnect hose -2-.
 - Unbolt upper section of intake line -3-.

Note:

Plug lower section of intake line.

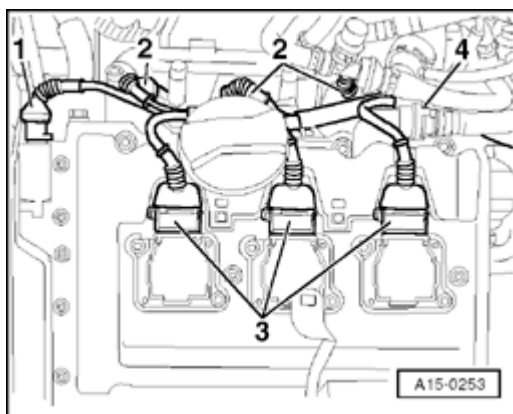

- A**
- Unplug connectors from injectors -2- (cylinder bank 4..6).

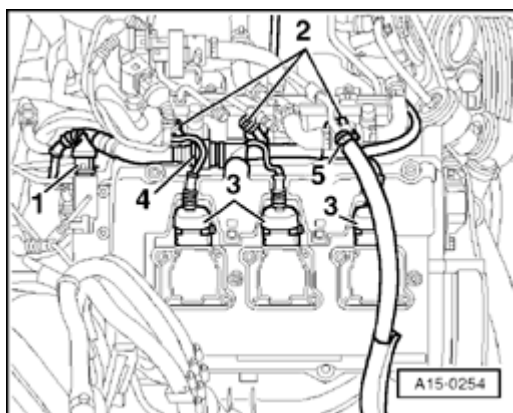

- A**
- Unplug connector for camshaft timing control -1- (cylinder bank 1..3).
 - Unplug connectors from injectors -2- (cylinder bank 1..3).
 - Unplug connectors from ignition coils -3- and move wiring harness clear (cylinder bank 1..3).
 - Pull crankcase breather -4- off cylinder head cover (cylinder bank 1..3).
 - Pull off hose -5- going to turbocharger intake side.
 - Remove ignition coils.

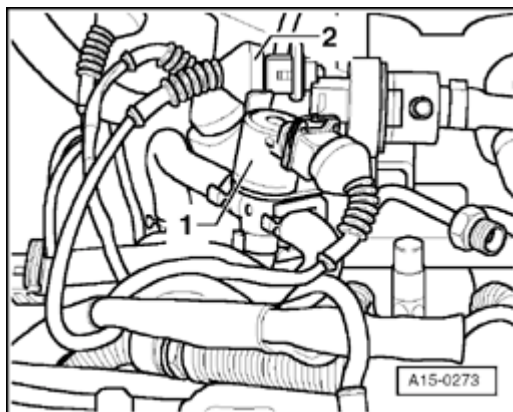

- A**
- Unclip solenoid valve for charge pressure control -1-.
 - Pull connector off EVAP valve -2-.

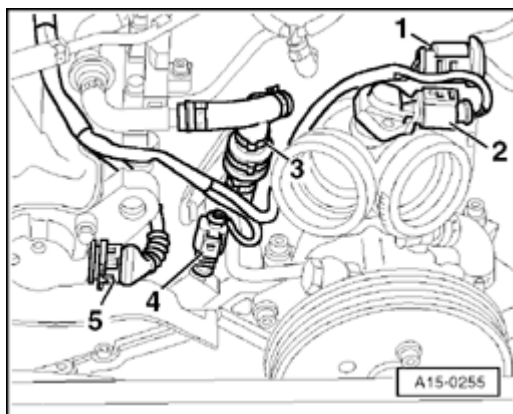

- A**
- Pull connector off throttle unit -1-.
 - Pull connector off charge air sensor -2-.
 - Pull off crankcase breather -3-.
 - Pull connector off intake air temperature sensor -4-.
 - Pull connector -5- off Hall sensor.

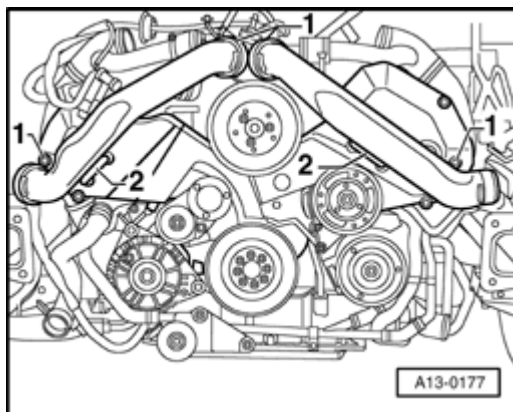

- A**
- Remove pressure lines -1-.

Note:

Watch position of retaining strips -2-.

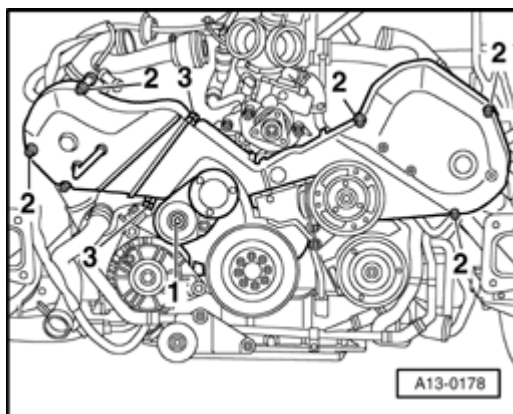

- A**
- Remove tensioner -1- for ribbed belt.
 - Remove toothed belt guards -2- (left and right).
 - Remove toothed belt guard -3- (center).

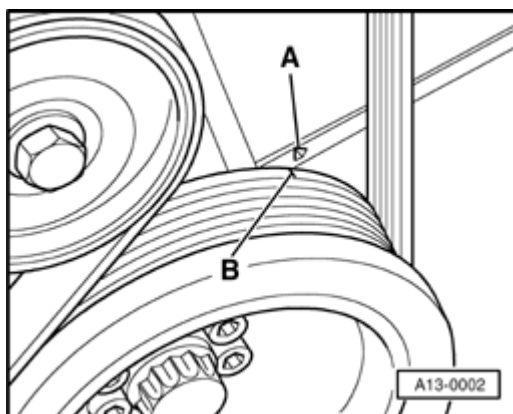

- A**
- Turn crankshaft to TDC by hand. Marks -A- and -B- must be aligned.

Note:

Turn over the engine at the central bolt on the crankshaft.

- Check position of camshafts: larger holes in securing plates on camshaft sprockets must align opposite one another on inside. If this is not the case, turn crankshaft one revolution further.
- Remove sealing plug from cylinder block, left.

The TDC drilling in the crankshaft must be visible (or able to be felt) in line with the sealing plug hole.

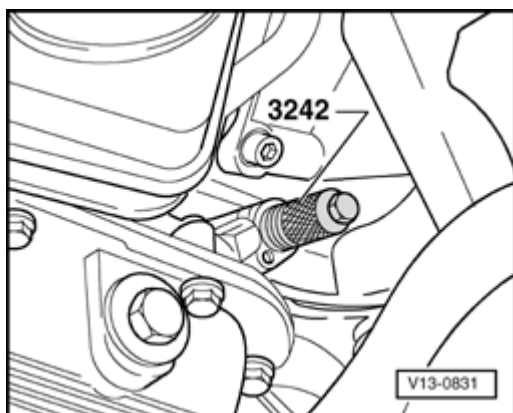

- A**
- Screw clamping bolt 3242 for crankshaft into sealing plug hole and tighten.

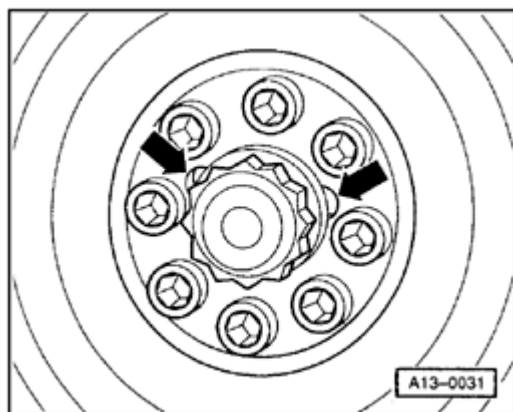

- A**
- Remove vibration damper on crankshaft.

Note:

The central bolt does not have to be loosened to remove the vibration damper.

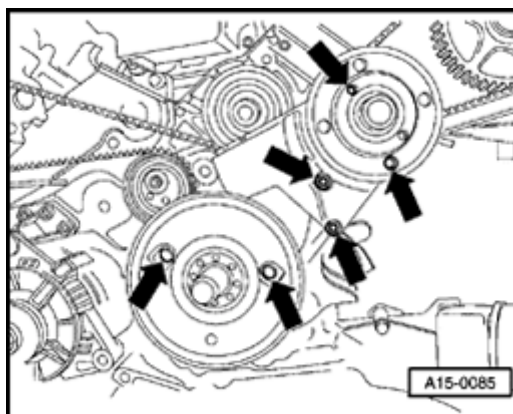

- A**
- Remove idler wheel for ribbed belt -arrows-.
 - Remove toothed belt guard behind vibration damper -arrows-.

Notes:

- ◆ *Mark the direction of rotation of the toothed belt with chalk or felt pen before removing. A used belt can break if it rotates in the wrong direction when reinstalled.*
- ◆ *The toothed belt tensioning element is oil-damped and can therefore only be compressed slowly by applying constant pressure.*

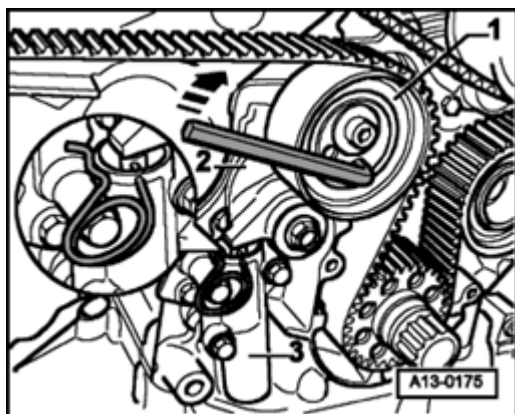

A

- Using a hexagon key, turn toothed belt tensioning roller -1- clockwise 8 mm in direction of arrow until tensioning lever -2- compresses tensioning element -3- sufficiently to enable a 2mm dia. spring pin to be installed in drilling and in plunger.
- Insert spring pin and release toothed belt tensioning roller.
Use spring pin from 2024 A.
- Insert camshaft clamp 3391 in the securing plates of the two camshafts.
- Loosen both camshaft bolts and remove approx. 5 turns.
- Take out camshaft clamp 3391.

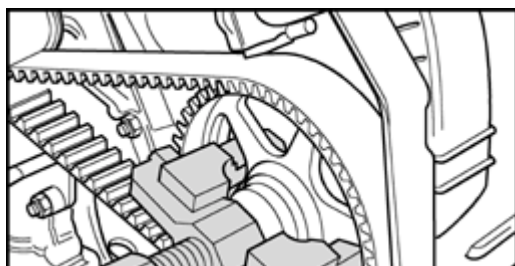

A

- Pull off both camshaft sprockets with special tool T40001.

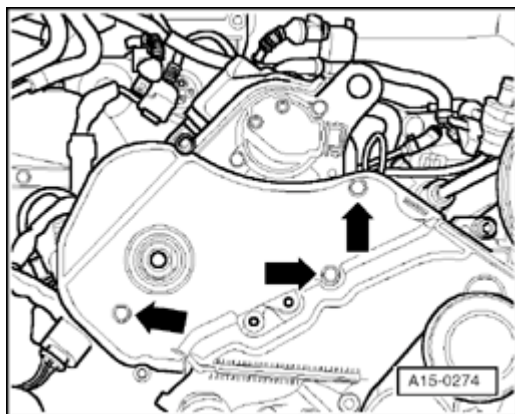

- A**
- Unbolt rear right toothed belt guard -arrows-.
 - Detach intake manifold using special tool 3249.

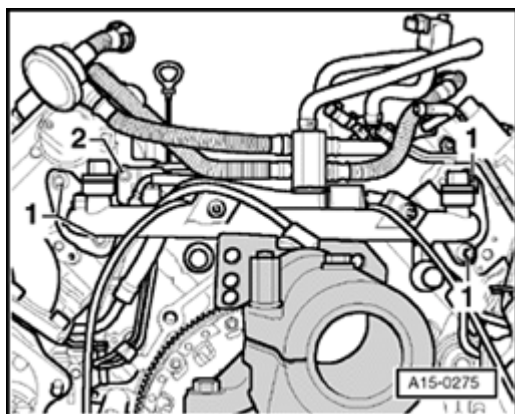

- A**
- Unbolt water line -1- and pull it towards the rear.
 - Unbolt bracket -2- from cylinder head.

15-51

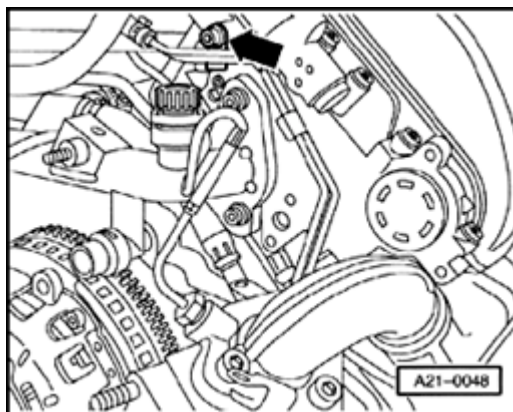

- A**
- Detach line -arrow- from cylinder head.
 - Detach line -2-.

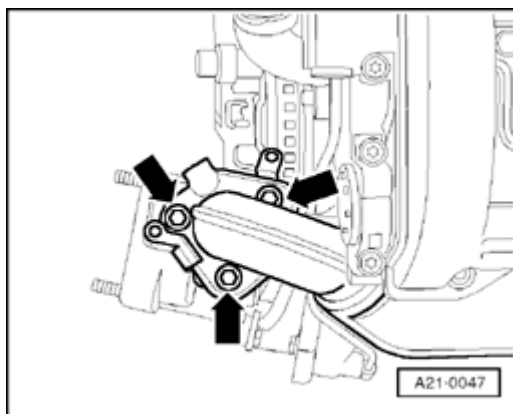

- A**
- Remove turbocharger -arrows-.

- Unbolt cylinder head cover.
- Loosen and remove cylinder head bolts in opposite sequence to tightening sequence using special tool 3452 (Polidrive).
- Carefully lift off cylinder head.

Note:

- ▲ Use special tool 3452 together with a normal commercial 10 mm socket when removing and installing.

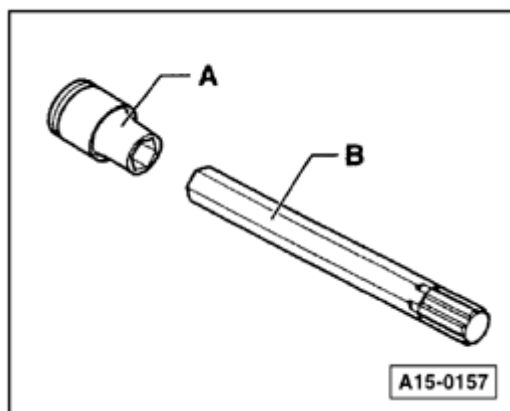

Installing

Notes:

- ◆ *Do not allow any oil or coolant to remain in the blind holes for the cylinder head bolts in the cylinder block.*
- ◆ *Install new cylinder head bolts.*
- ◆ *Connecting vacuum hoses ⇒ [Page 10-28](#) .*

When installing a new cylinder head:

- Screw in centering pin for intake manifold.

The cylinder head supplied as a replacement part can be used on both sides (left or right). But a sealing cap (core plug) must be installed in the front end of the cylinder head in each case.

- Coat outside circumference of sealing cap (core plug) with sealant AMV 188 001 02.

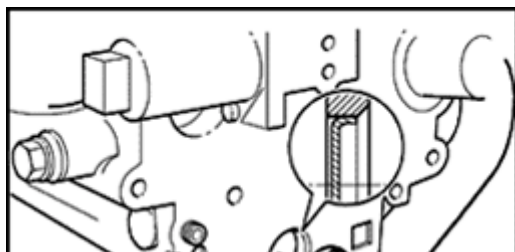

A

- Using drift VW 295, knock in sealing cap (core plug) until outside rim is flush with end of chamfer in cylinder head.

- Before installing cylinder head in position, turn crankshaft and camshafts to TDC of No. 3 cylinder.
- Install cylinder head gasket on dowel sleeves. Marking "oben" (top) or part number must face towards cylinder head.
- Install cylinder head, insert cylinder head bolts and tighten finger-tight.

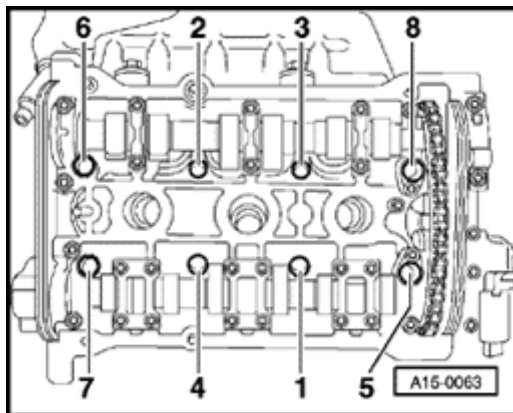

A

- Tighten cylinder head bolts in two stages in sequence shown, as follows:
 - ◆ Stage 1 = 60 Nm.
 - ◆ Stage 2 = turn a further $1/2$ turn (180°) with a rigid wrench (turning $2 \times 90^\circ$ is also permissible).

It is not necessary to torque down cylinder head bolts again after repairs have been completed.

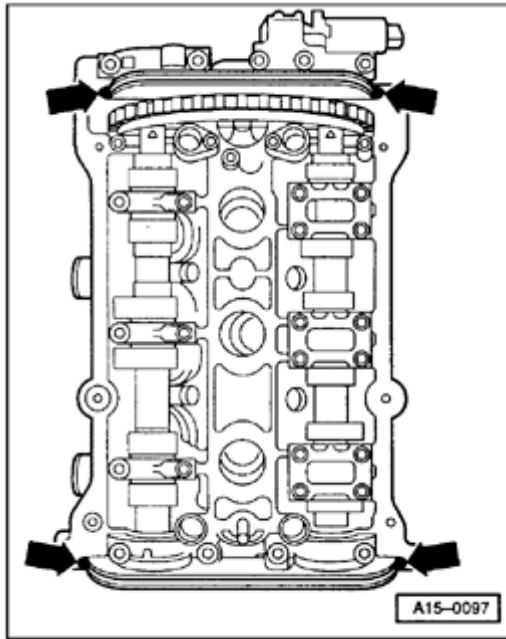

A

- Seal end points of joints between bearing caps and cylinder head.
- Before installing cylinder head cover and gasket, carefully apply a small quantity of sealant D 454 300 A2 at four end points of sealing surfaces on cylinder head -arrows-, using a small screwdriver.

Tightening torques

Component		Nm
Bolts	M6	10
Bolts	M8	20
Camshaft bearing caps and camshaft adjuster		10
Exhaust manifold to cylinder head		25
Front exhaust pipe to exhaust manifold		25
Oxygen sensor		50
Spark plugs		25
Toothed belt sprocket to camshaft		55
Intake manifold to cylinder head		10
Cylinder head cover		10

Cylinder head, checking for distortion

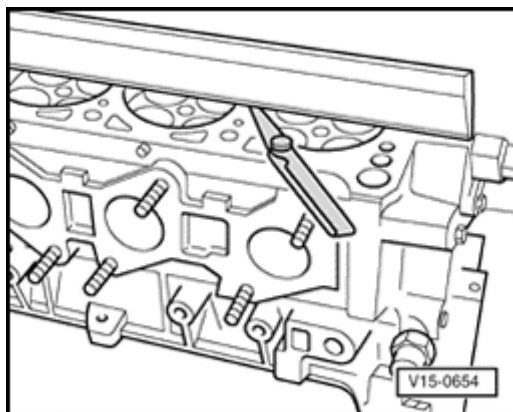

- Measure at several points with straight-edge.
- ◆ Maximum permissible distortion: 0.1 mm.

Cylinder head, reworking

- A** Reworking cylinder head (skimming) is only permissible down to a minimum dimension of $a = 139.25$ mm.

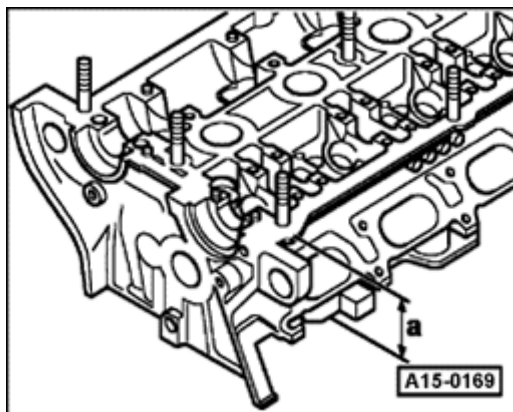

Compression, checking

Test requirements:

- Engine oil temperature at least 30 ° C.
- Battery fully charged.

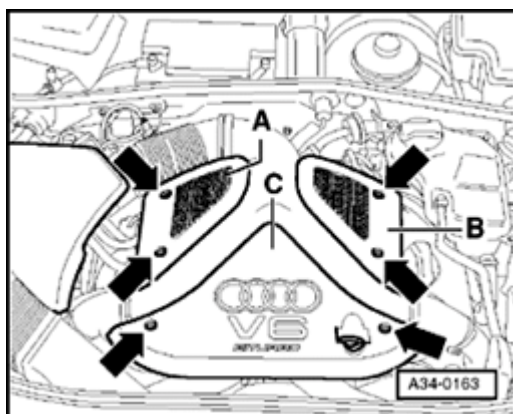

- A** - Remove bolts -arrows- and remove engine cover panels -A...C-.

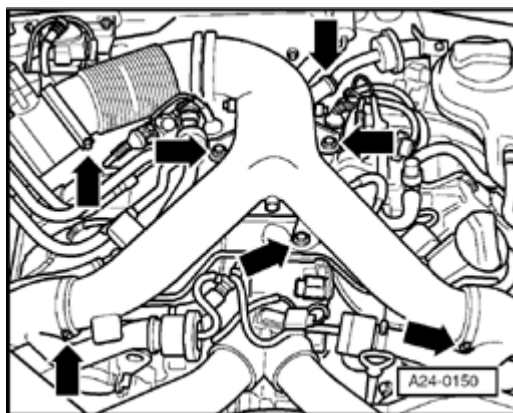

- A** - Remove air duct -arrows-.

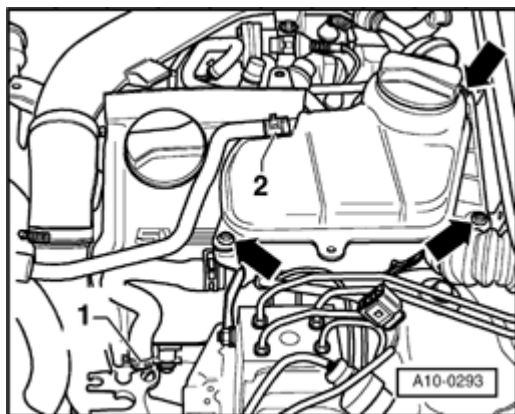

- A**
- Remove coolant reservoir -arrows- and move it clear to the side.

Note:

Leave coolant hoses connected.

- Unplug connector from coolant level monitor.
- Remove cover panel from cylinder head cover (cylinder bank 4 - 6).

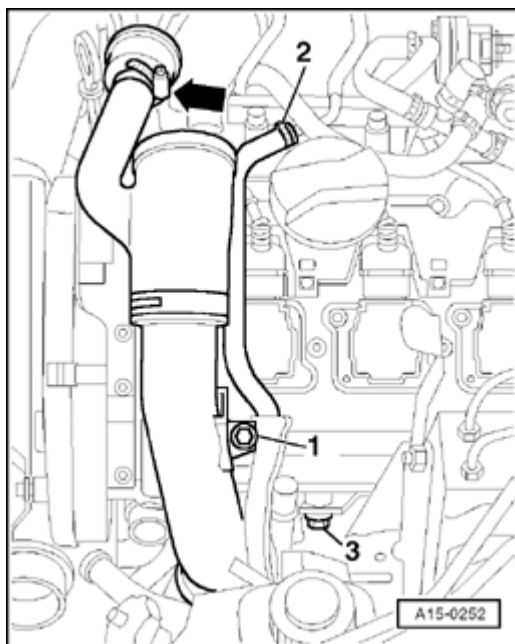

- A**
- Release hose clamp -arrow-.
 - Remove intake line -1-.
 - Disconnect hose -2-.
 - Detach water line -3-.

Note:

Plug lower section of intake line.

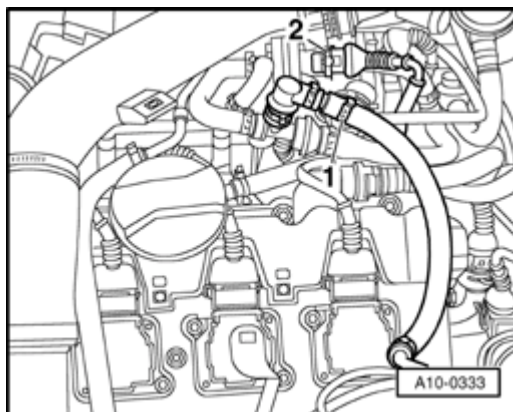

- A**
- Pull off hose -1-.

WARNING!

Fuel system is under pressure. Before opening the system, place a cloth around the connection. Then release pressure by carefully loosening the connection.

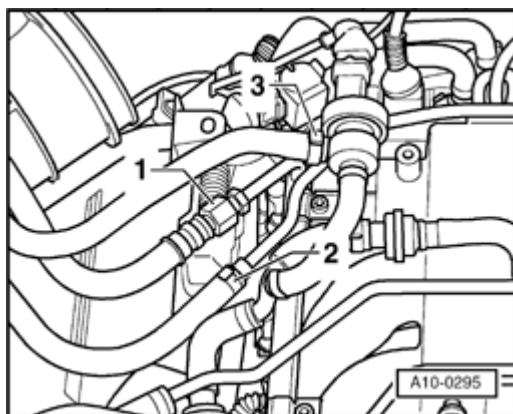

- A**
- Disconnect fuel supply line and fuel return line -1- and -2-, and move fuel lines clear.
 - Pull hose off EVAP valve -3-.

15-61

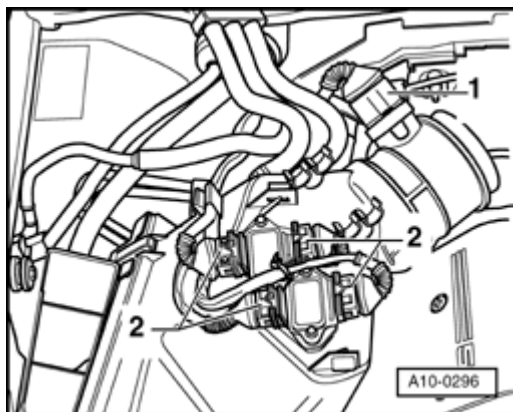

- A**
- Unplug connector -1- from air mass meter.
 - Unplug connectors -2- from ignition output stages, and move wiring clear.
 - Remove air cleaner.

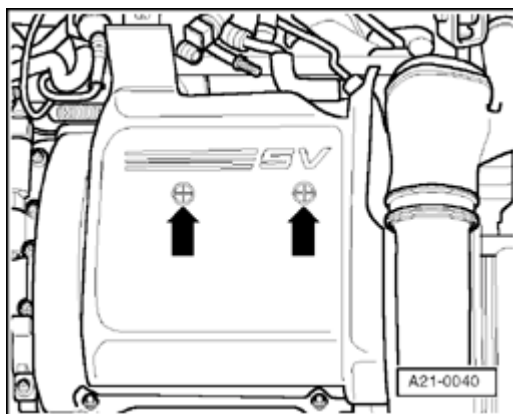

- A**
- Remove cover panel from right-hand cylinder head cover -arrows-.

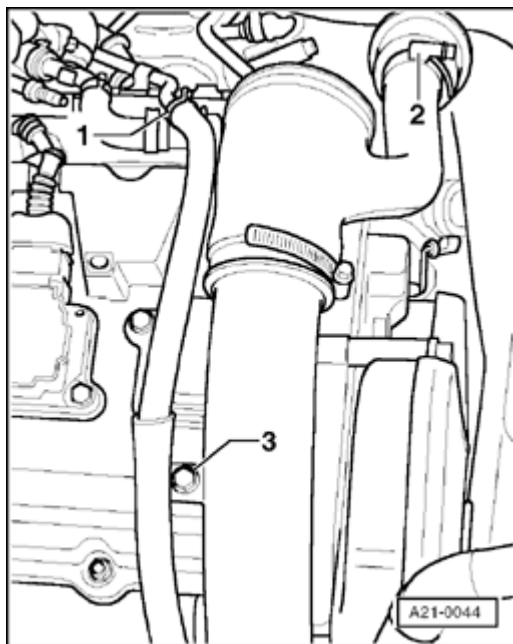
**A**

- Disconnect hose -1-.
- Disconnect hose -2-.
- Detach upper section of pressure line -3-.

Note:

Plug lower section of pressure line.

- Pull crankcase breathers off cylinder head covers.
- Pull plug connectors off ignition coils.
- Remove ignition coils.
- Unplug connectors from all 6 injectors.
- Disconnect 5-pin connector at power output stage of ignition coils.
- Open throttle fully.
- Use compression tester VAG 1381 or VAG 1763.
- Operate starter until pressure reading on tester no longer rises.

Compression pressure values

New	Wear limit	Max. permissible difference between cylinders
9 ... 13 bar	7 bar	3 bar

Installing

Install in reverse sequence; note the following points.

- install fuse No. 28 (for fuel pump).
- Erase Diagnostic Trouble Code (DTC) memory.

Note:

Malfunctions will have been stored in the memory because the connector to the Hall sensor has been unplugged. Therefore interrogate and erase the DTC memory after the test.

Tightening torque

Component	Nm
Ignition coils to cylinder head	10
Spark plugs in cylinder head	30

Sealing cap (core plug) in cylinder head, installing

The cylinder head supplied as a replacement part can be used on both sides (left or right). But a sealing cap (core plug) must be installed in the front end of the cylinder head in each case.

- Coat outside circumference of sealing cap (core plug) with sealant AMV 188 001 02.

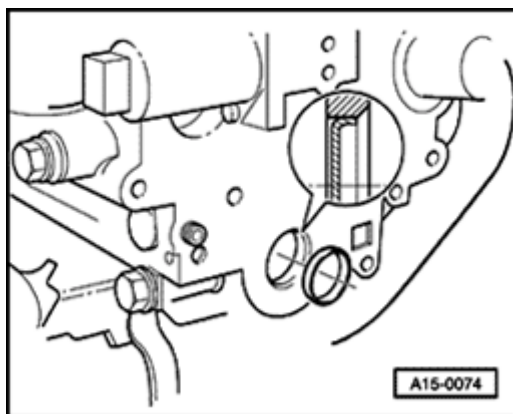

A

- Using drift VW 295, knock in sealing cap (core plug) until outside rim is flush with end of chamfer in cylinder head.

Camshaft adjustment, checking function

Special tools and equipment

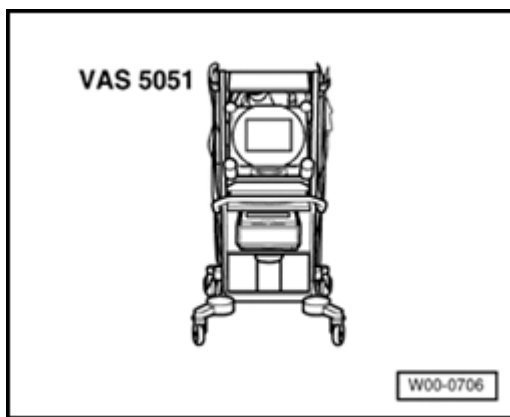

A

- ◆ VAS 5051 with VAG 5051/1
- or
- ◆ VAG 1551 with VAG 1551/3A

Test requirement:

- Coolant Temperature at least 80° C.

WARNING!

- ◆ ***During a road test in an airbag-equipped vehicle, test equipment must always be fastened to and operated from the rear seat by a second technician.***
- ◆ ***When driving or riding in an airbag-equipped vehicle, NEVER hold the scan tool or other test equipment in your hands or lap while in motion. Objects between you and the airbag increase the risk of injury in an accident.***

Test sequence

- Connect VAS 5051 tester or VAG 1551 scan tool and select control module for engine electronics using "address word" 01. Engine must run at idle for this.

⇒ [Repair Manual, 2.7 Liter V6 5V BiTurbo Fuel Injection & Ignition, Engine Code\(s\): APB, Repair Group 01](#)

Rapid data transfer HELP
Select Function XX



When indicated on display

- Press buttons -0- and -4- to select "Initiate basic setting" and press -Q- button to confirm input.

Initiate basic setting Q
Input display group number XXX



When indicated on display

- Press buttons -0-, -9- and -4- to select "display group number 094" and press -Q- button to confirm input.

System in basic setting 94 →
1 2 3 4



When indicated on display

- Camshaft adjustment is checked for function.
- Increase engine speed to above 2000 RPM.

	Display fields			
	1	2	3	4
Display group 94: Function of camshaft adjustment				
Display	1 RPM	Text	Text	Text
Indicated	Engine speed (RPM)	Camshaft adjustment	Test result, Bank 1	Test result, Bank 2
Specified value	>2000	Cs-CM. ON	Test ON Sys. OK	Test ON Sys. OK
Note:				

If "not OK" is indicated in display field 3 and/or 4:

- Check solenoid valve for camshaft adjustment.

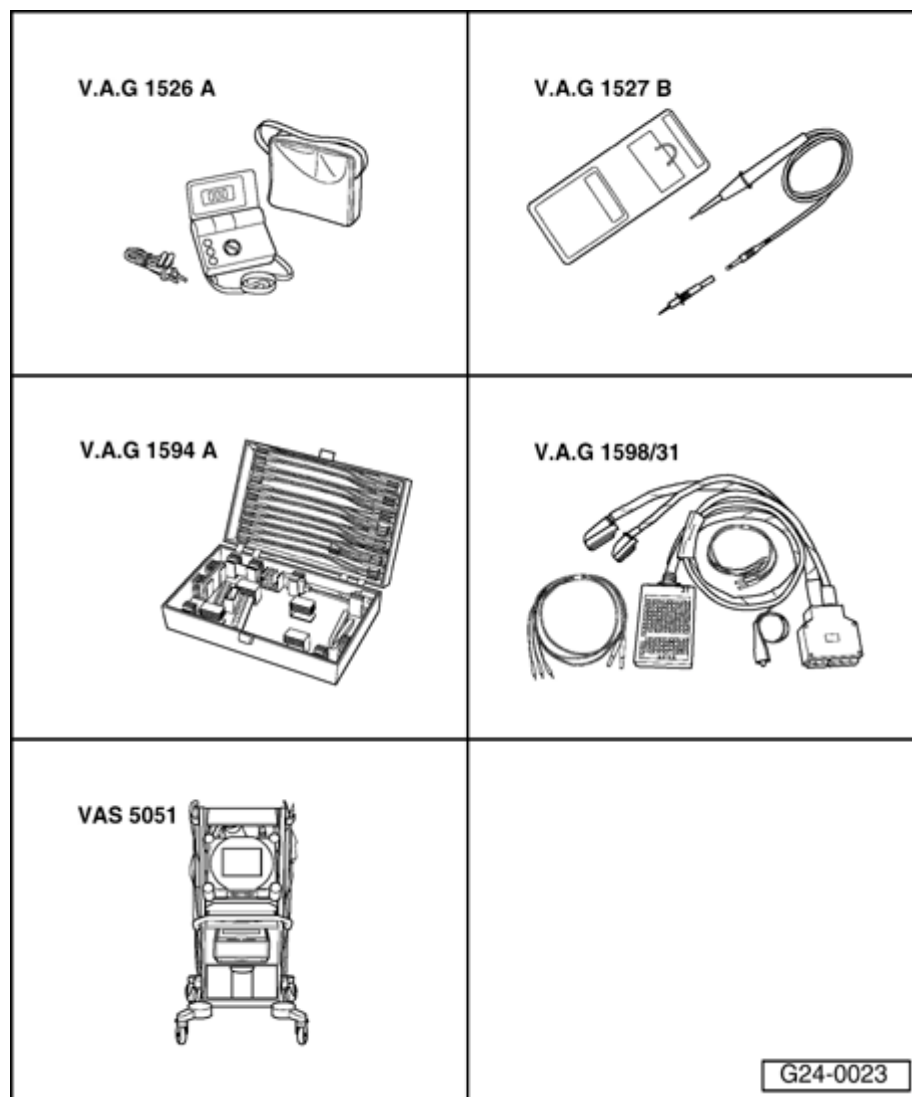

Solenoid valve for camshaft adjustment, checking

Special tools and equipment

- ◆ VAG 1526A
- ◆ VAG 1527B
- ◆ VAG 1594A
- ◆ VAG 1598/31
- ◆ VAS 5051
- or
- ◆ VAG 1551 with VAG 1551/3A

- Initiate output Diagnostic Test Mode (DTM) and activate the valve for camshaft adjustment.

⇒ [Repair Manual, 2.7 Liter V6 5V BiTurbo Fuel Injection & Ignition, Engine Code\(s\): APB, Repair Group 01](#)

If valves do not click during output Diagnostic Test Mode (DTM):

Checking internal resistance

- Switch ignition off.
- Remove bolts (arrows) and remove engine covers -A- and -B-.

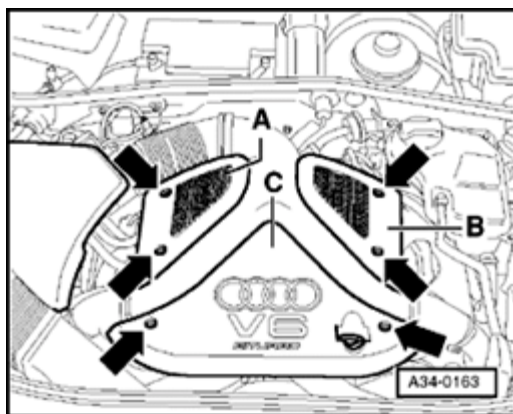

A

- Remove air distributor (arrows).

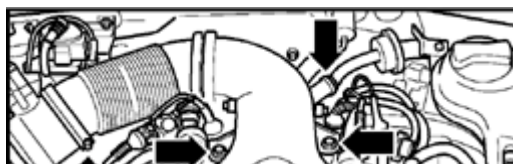

A

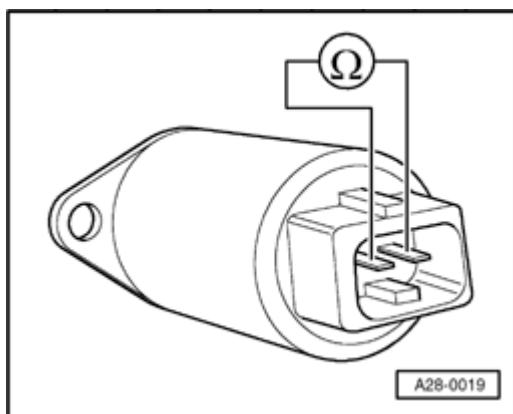

- Disconnect connector from solenoid valve.
- A** - Connect multimeter at valve for resistance measurement.
 - ◆ Specified value: 10 ... 18 Ω

If specified value is not obtained:

- Replace valve.

Checking voltage supply

- Disconnect connector from solenoid valve.

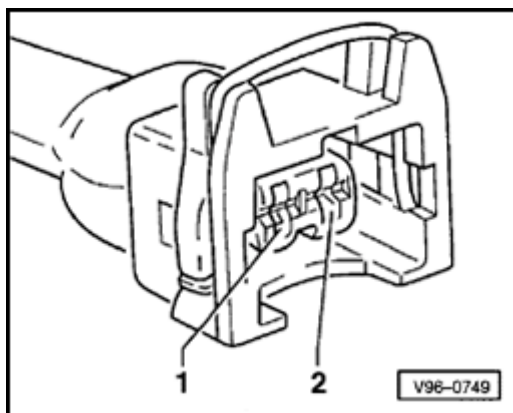

- A** - Connect VAG 1527B voltage tester as follows:

Harness connector terminal	Measure to
1	Engine Ground (GND)

- Operate starter briefly.
 - ◆ LED must light.

If LED does not light:

- Perform following tests marked with dots:
 - Check fuse of solenoid valves for camshaft adjustment.

⇒ *Electrical Wiring Diagrams, Troubleshooting & Component Locations*

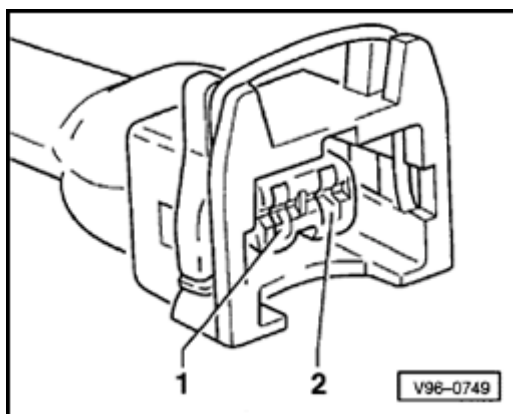

A

- Check wire connection from terminal 1 of connector via fuse -S234- (in fuse holder, socket 34) to Fuel Pump (FP) relay for open circuit:

⇒ *Electrical Wiring Diagrams, Troubleshooting & Component Locations*

- Repair open circuit if necessary.

If no malfunctions are detected:

- Check Fuel Pump (FP) relay.

⇒ [*Repair Manual, 2.7 Liter V6 5V BiTurbo Fuel Injection & Ignition, Engine Code\(s\): APB, Repair Group 24*](#)

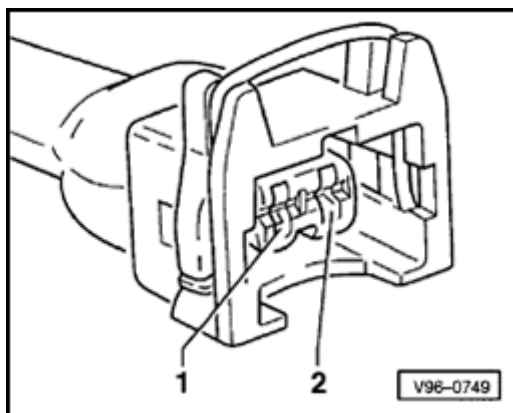

Checking activation

A

- Connect VAG 1527B voltage tester between terminal 1 (+) and 2.
- Initiate output Diagnostic Test Mode (DTM) and activate valve for camshaft adjustment.

⇒ [Repair Manual, 2.7 Liter V6 5V BiTurbo Fuel Injection & Ignition, Engine Code\(s\): APB, Repair Group 01](#)

◆ LED must blink.

If LED does not blink or if it remains constantly lit:

- Connect VAG 1598/31 test box at wiring harness to ECM, do not connect ECM.

⇒ [Repair Manual, 2.7 Liter V6 5V BiTurbo Fuel Injection & Ignition, Engine Code\(s\): APB, Repair Group 24](#)

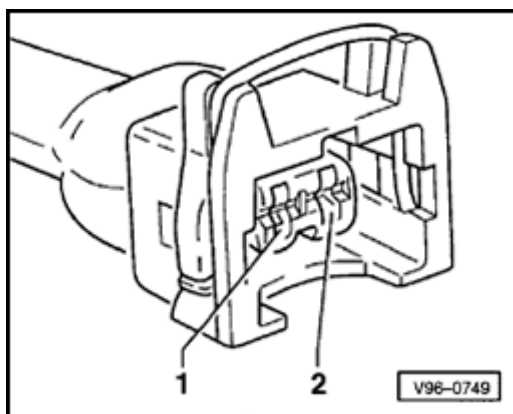

A

- Check following wire connections for open circuit and short circuit to Ground (GND) and B+:

Valve 1 for camshaft adjustment -N205- and valve 2 for camshaft adjustment -N208-

Harness connector terminal	VAG 1598/31 or test box Bushing
2	⇒ <i>Electrical Wiring Diagrams, Troubleshooting & Component Locations</i>

- Repair Ground (GND) connection or open circuit if necessary.

If wire connection is OK:

- Replace Engine Control Module (ECM).

⇒ [Repair Manual, 2.7 Liter V6 5V BiTurbo Fuel Injection & Ignition, Engine Code\(s\): APB, Repair Group 24](#)

If no malfunctions are detected:

- Replace mechanical camshaft adjuster.

Camshafts and camshaft adjusters, removing and installing

Removing

- Cylinder head installed

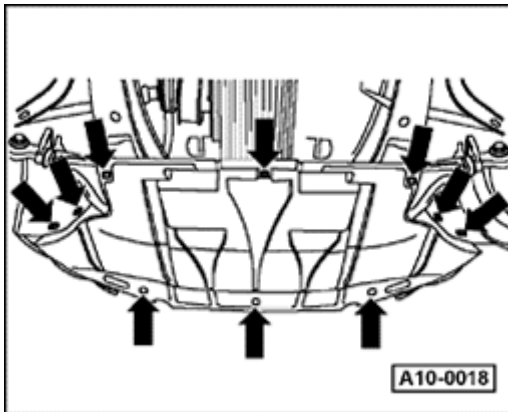

A

- Remove noise insulation panel -arrows-.
- Remove front bumper
⇒ [Repair Manual, Body Exterior, Repair Group 63](#)
- Move lock carrier to service position
⇒ [Repair Manual, Body Exterior, Repair Group 50](#)
- Remove ribbed belt ⇒ [Page 13-1](#) .
- Remove toothed belt ⇒ [Page 13-4](#) .

Left cylinder head

- Remove left-hand cylinder head cover ⇒ [Page 15-22](#) .

Right cylinder head

- Remove right-hand cylinder head cover ⇒ [Page 15-25](#)

All:

- Unbolt Hall sensor housing (10 Nm).
- Remove bolt securing Hall sensor rotor (20 Nm) and carefully lever off rotor using a screwdriver.
- Insert camshaft clamp 3391 in securing plates of two camshafts.
- Loosen both camshaft bolts and remove approx. 5 turns.
- Take out camshaft clamp 3391.

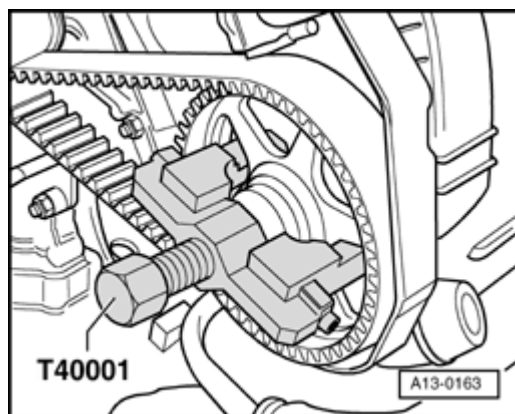

- A**
- Pull off both camshaft sprockets with special tool T40001.
 - Using a screwdriver, carefully pry oil feed lines for camshaft bearings out of camshaft bearings.

Make sure that the retaining catches do not break off when levering out the oil lines.

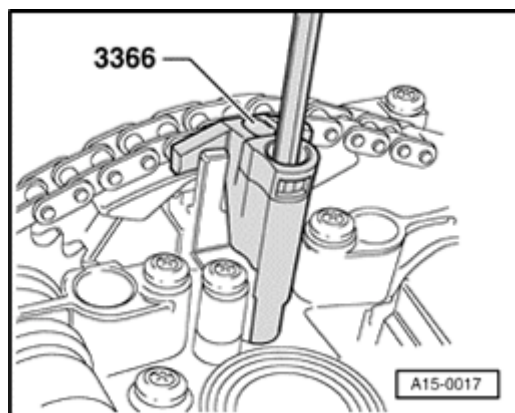

- A**
- Secure camshaft adjuster using retainer for chain tensioner 3366.

Note:

Do not over tighten retainer for chain tensioner, otherwise camshaft adjuster can be damaged.

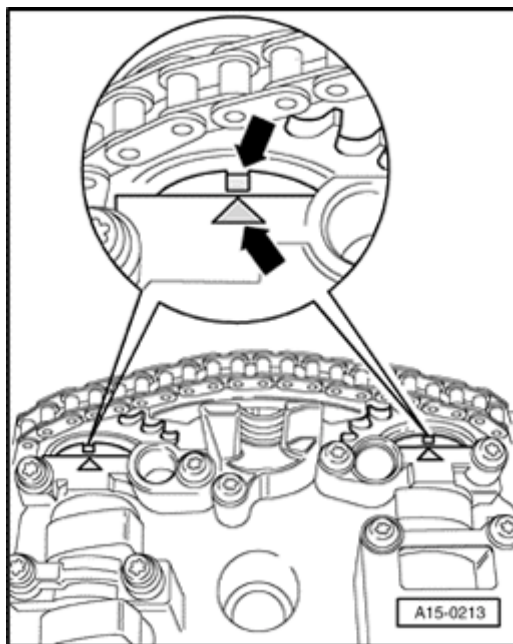

- A**
- Check TDC position of camshafts once again.

Note:

The two markings on the camshafts must be in line with the two arrows on the bearing caps.

- Clean drive chain and camshaft chain sprockets in vicinity of arrows on bearing caps and mark position of chain on sprockets with paint opposite two arrows.

Notes:

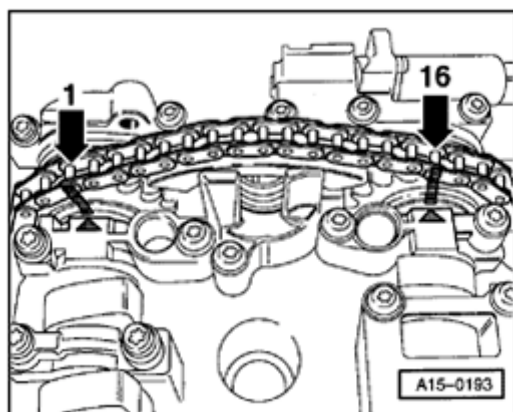

- A**
- ◆ *The distance between the two arrows (and thus between the paint markings) is 16 rollers on the chain.*
 - ◆ *The notch on the exhaust camshaft is offset slightly towards the inside in relation to chain roller -1-.*
 - ◆ *Do not mark the chain with a center punch or by making a notch or similar.*

15-79

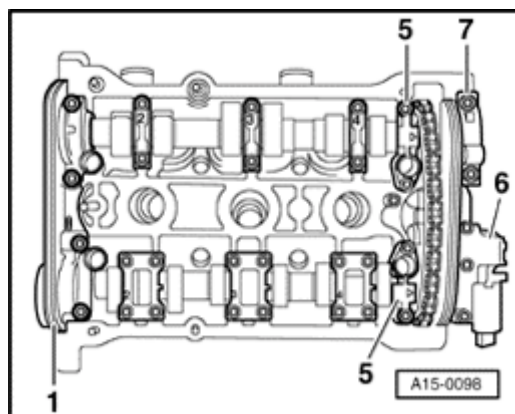

A

- Remove bolts securing camshaft adjuster -6-.
- Remove bearing caps 1, 3, 5 and 7 from inlet and exhaust camshafts and place them in correct order on a clean surface.
- Loosen bearing caps 2 and 4 alternately and in diagonal sequence, and remove from both camshafts.
- Take out both camshafts together with camshaft adjuster.

Installing

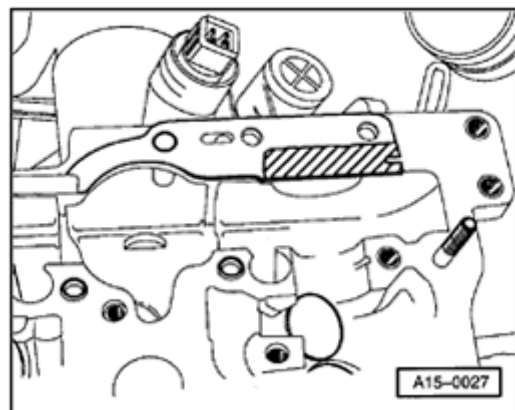

A

- Replace rubber/metal gasket for camshaft adjuster and apply a thin coat of sealant D 454 300 A2 to the shaded area.

- Install drive chain on camshaft sprockets as follows:

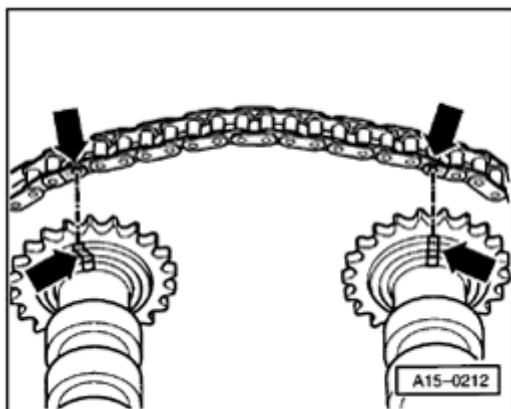

A

- ◆ When the old chain is being used again, install the chain so that the paint markings (arrow) are in line.

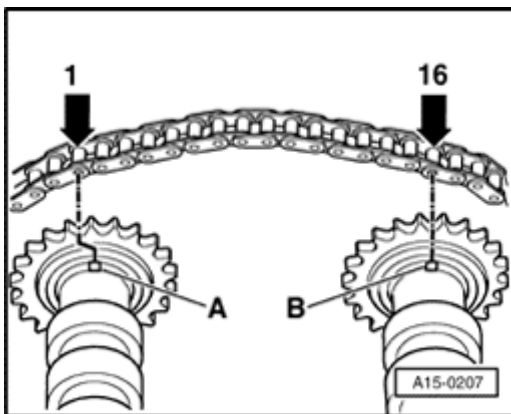

A

- ◆ When a new chain is being installed, the distance between the notches -A- and -B- on the camshafts must be 16 rollers on the chain. The illustration shows the exact positions of the 1st and 16th rollers on the sprockets.
- ◆ Notch -A- is offset slightly towards the inside in relation to chain roller -1-.
- Insert camshaft adjuster inside chain (second mechanic required).
- Locate camshafts with chain and camshaft adjuster in cylinder head.
- Oil camshaft bearing surfaces.

Notes:

- ◆ *The dowel sleeves for the bearing caps and camshaft adjuster must be in the cylinder head.*
- ◆ *Install the bearing caps so that the markings on the bearing caps can be read from the inlet side of the cylinder head.*

- Tighten bolts securing chain tensioner (watch position of dowel sleeves).

- A
- Tighten bearing caps 2 and 4 of inlet and exhaust camshafts alternately and in diagonal sequence (watch position of dowel sleeves).
 - Install two bearing caps next to chain sprockets on inlet and exhaust camshafts.

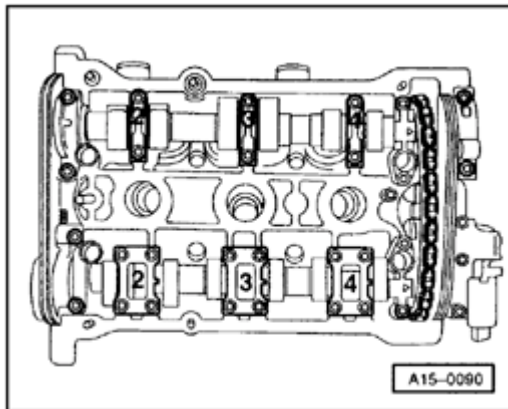

- Check correct setting of camshafts:

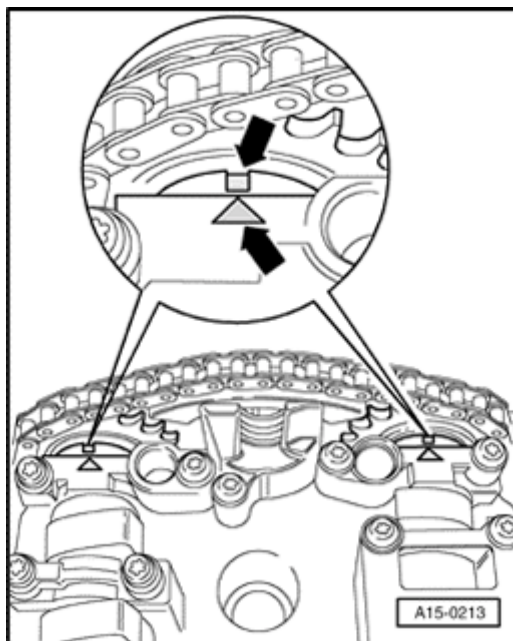

A

- ◆ The two markings on the camshafts must be in line with the two arrows on the bearing caps -arrows-.

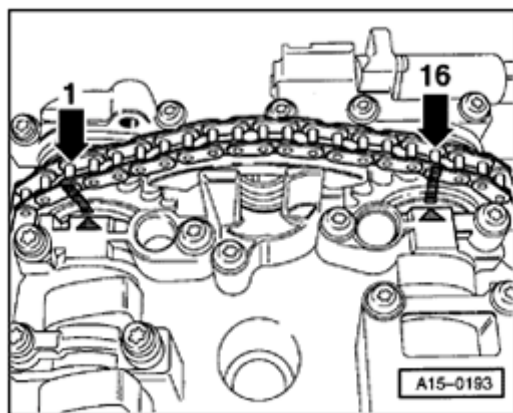

A

- ◆ The distance between the two arrows on the bearing caps (or between the paint markings) is 16 rollers on the chain.
- ◆ The notch on the exhaust camshaft is offset slightly towards the inside in relation to chain roller -1-.

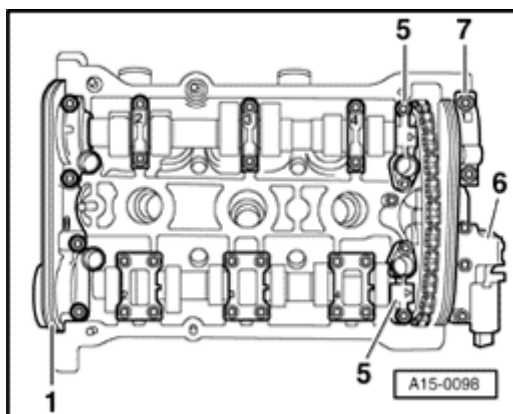

- A
- Prepare shaded areas on double bearing cap -1- and bearing cap -7-.

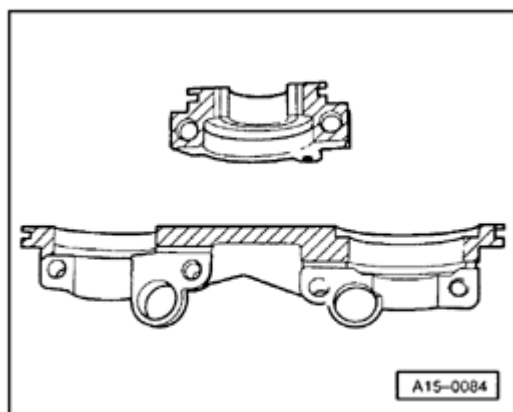

- A
- ... by applying a thin coat of sealant D 454 300 A2 and install bearing caps (watch position of dowel sleeves).
 - Install remaining bearing caps (watch position of dowel sleeves).
 - Install new oil feed lines for camshaft bearings.
 - Install new oil seals for inlet and exhaust camshafts; installing ⇒ [Page 15-10](#) .
 - Remove retainer for chain tensioner 3366.

Notes:

- ◆ *When new lifters have been installed the engine must not be started for about 30 minutes. The hydraulic compensation elements must settle (otherwise valves will strike pistons). Then turn crankshaft two full revolutions before starting.*
- ◆ *After working on the valve gear, turn over the engine carefully at least two revolutions by hand to ensure that none of the valves make contact when the starter is operated.*

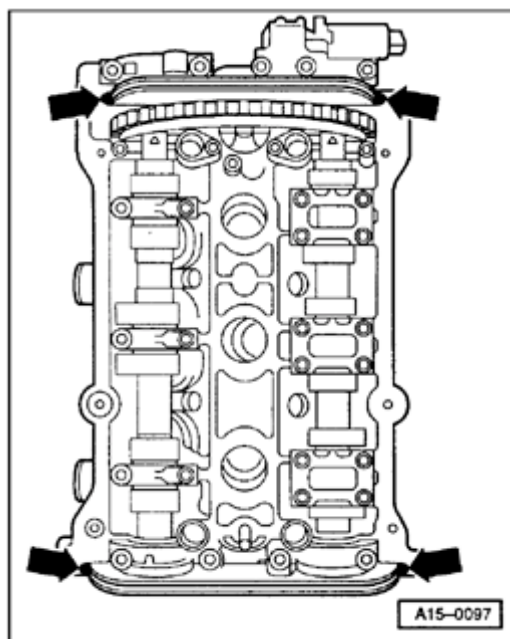

A

- Seal end points of joints between bearing caps and cylinder head.
- Before installing cylinder head cover and gasket, carefully apply a small quantity of sealant D 454 300 A2 at four end points of sealing surfaces on cylinder head -arrows-, using a small screwdriver.

- Install cylinder head covers ⇒ [Page 15-22](#) .
- Install toothed belt ⇒ [Page 13-4](#) .
- Install ribbed belt ⇒ [Page 13-1](#) .

Tightening torques

Component		Nm
Bolts	M6	10
	M8	20
Except for the following:		
Bearing caps to cylinder head		10
Camshaft adjuster to cylinder head		10
Hall sensor rotor to camshaft		25
Hall sensor housing to cylinder head		10
Camshaft sprocket to camshaft		55
Camshaft bearing cap and camshaft adjuster		10
Cylinder head cover		10

Camshaft axial clearance, checking

- Remove camshafts ⇒ [Page 15-75](#) .
- Remove lifters.
- Install camshafts in cylinder head without drive chain and secure by tightening bearing caps 2 and 4.

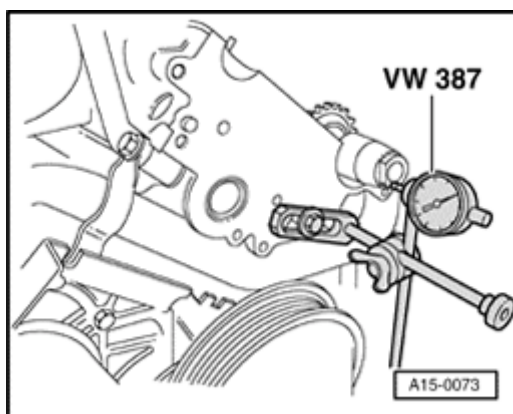

A

- Attach dial gauge to cylinder head with universal dial gauge bracket VW 387.
- Press camshaft against dial gauge by hand.
- Set dial gauge to -0-.
- Press camshaft away from dial gauge.
- Note reading on gauge:

New	Wear limit
0.05 ... 0.15 mm	0.20 mm

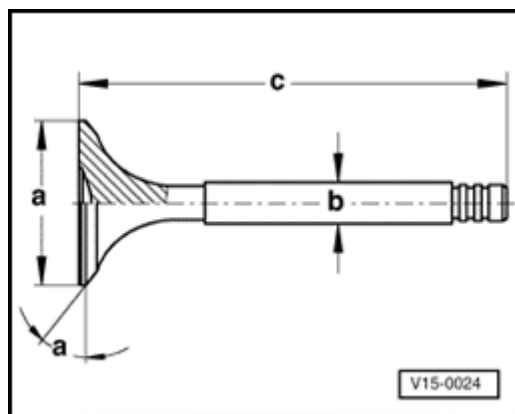

A Valve dimensions, checking

Note:

Valves must not be reworked. Only grinding-in (lapping) is permitted.

Dimension	Inlet valve	Exhaust valve
a = diameter mm	26.8 ... 27.0	29.8 ... 30.0
b = diameter mm	5.96 ... 5.97	5.94 ... 5.95
c = mm	104.84 ... 105.34	103.64 ... 104.14
$\alpha = \angle^\circ$	45	45

WARNING!

Worn sodium-cooled exhaust valves must be treated as follows before disposal:

- ♦ **Saw the valves into two sections with a metal saw at a point between the center of the valve stem and the valve head. The valves must not come into contact with water when this is done. Then throw the valves into a bucket of water (not more than ten at a time) and step back, because a chemical reaction occurs when the sodium filling burns. After this treatment the valves can be disposed of in the normal way.**

Hydraulic lifters, checking

Notes:

- ◆ *Replace malfunctioning lifters completely (lifters cannot be adjusted or repaired).*
- ◆ *When new lifters have been installed the engine must not be started for about 30 minutes (otherwise valves will strike pistons).*
- ◆ *Irregular valve noises when starting engine are normal.*
- Start engine and run until coolant temperature reaches approx. 80 ° C.
- Increase engine speed to about 2500 RPM for approx. 2 minutes: if necessary, perform road test.

If the hydraulic lifters are still noisy, locate malfunctioning lifters as follows:

- Remove cylinder head cover.
- Rotate crankshaft clockwise by turning securing bolt for toothed belt sprocket until cams of lifters to be checked are pointing upward.

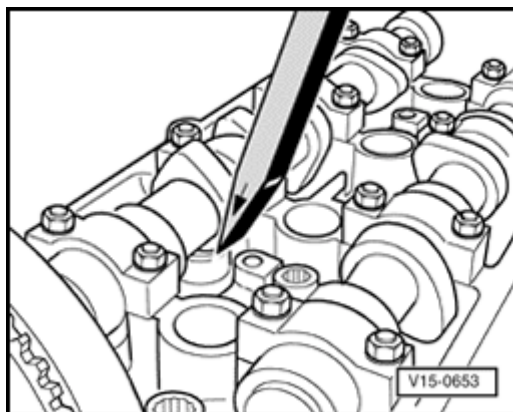

A

- Measure clearance between cam and lifter.
- Push lifter down with a wooden or plastic wedge. If a 0.20 mm feeler gauge can then be inserted between camshaft and lifter, replace lifter: removing and installing camshafts and camshaft adjuster ⇒ [Page 15-75](#)

Note:

If irregular valve noise occurs repeatedly during short journeys and disappears after extended driving, the oil check valves must be replaced ⇒ [Page 17-12](#) .

Valve stem seals, replacing

- Cylinder head installed
- Remove ribbed belt ⇒ [Page 13-1](#) .
- Remove toothed belt ⇒ [Page 13-4](#) .
- Remove camshafts ⇒ [Page 15-75](#) .
- Remove lifters and put them down with the contact surface downwards. Ensure that lifters are not interchanged.
- Remove spark plugs.
- Set piston of relevant cylinder to bottom dead center (BDC).

Note:

Tight cotters can be released by tapping lightly on the valve lever with a hammer.

Exhaust side

Note:

Before attaching the valve assembly appliance, remove the two studs in the center of the cylinder head and the three upper studs (inlet side) for securing the cylinder head cover.

- Screw pressure hose VW 653/3 with sealing ring finger-tight into spark plug thread of relevant cylinder, and maintain a constant pressure of at least 6 bar.

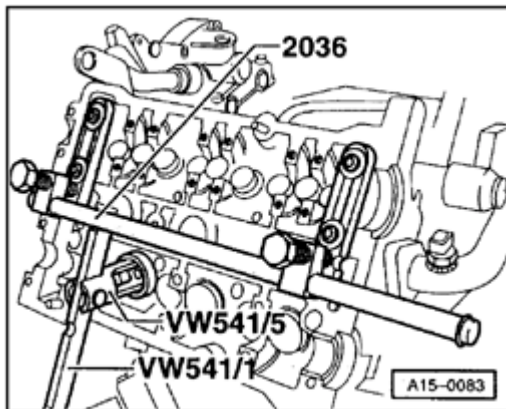

A

- Attach valve assembly appliance 2036 as illustrated: use M6 x 40 bolts with large washers.
- Remove valve spring using valve lever VW 541/1 and thrust piece VW 541/5.
- Take out valve spring and valve spring plate.
- Pull off valve stem seal with 3047 A.

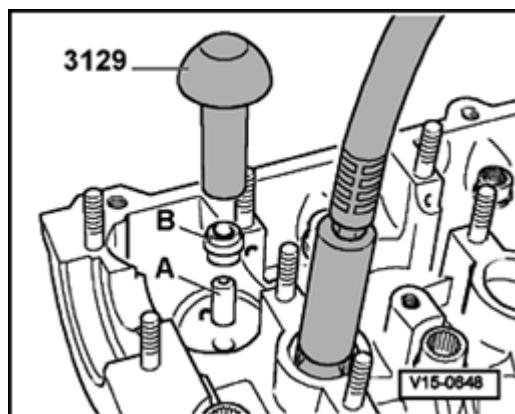

- A**
- To prevent damage to the new valve stem seals, place plastic sleeve - A- on the valve stem.
 - Lightly oil sealing lip.
 - Insert valve stem seal -B- (without oiling outside of seal) into installing tool 3129 and carefully push it down onto the valve guide.
 - When installing new valves, lightly oil valve stems before installing.

Inlet side

Note:

The inlet valves are installed in the cylinder head at different angles.

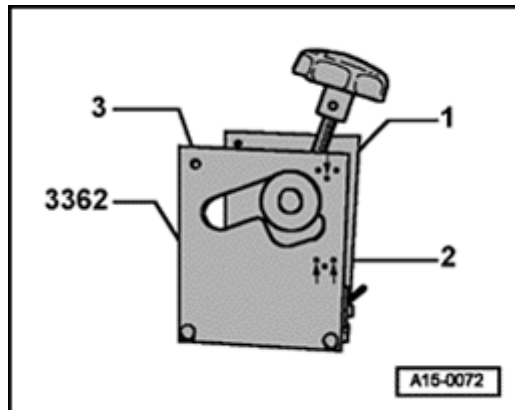

- A**
- Valve spring compressor 3362 can be set accordingly to two different positions:
- 1 - Upper position for center valve
 - 2 - Lower position for the two outer valves
 - 3 - Threads on each side to take M6 x 25 bolts for securing spring compressor to cylinder head

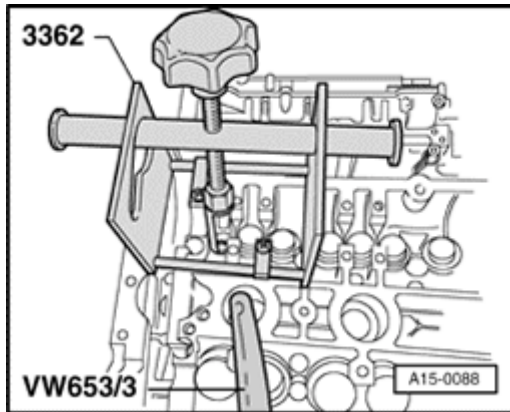

A

- Mount spring compressor 3362 on cylinder head with two bolts supplied, as in illustration.
- Screw pressure hose VW 653/3 with sealing ring finger-tight into spark plug thread of relevant cylinder, and maintain a constant pressure of at least 6 bar.
- Set position of spring compressor for relevant valve, and remove valve spring using threaded spindle.

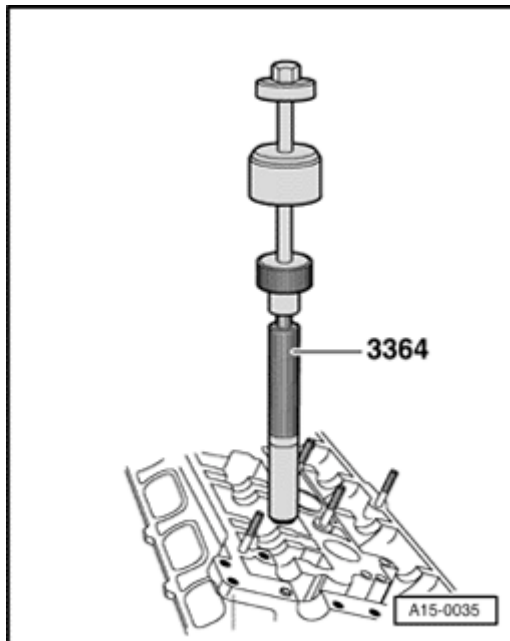

A

- Pull off valve stem seal using 3364.

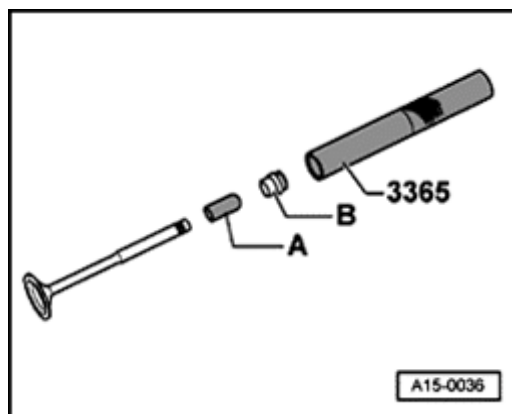

A

- To prevent damage to new valve stem seals, place plastic sleeve -A- on valve stem.
- Lightly lubricate sealing lip with oil.
- Insert valve stem seal -B- (without oiling outside of seal) into installing tool 3365 and carefully push it down onto valve guide.
- When installing new valves, lightly oil valve stems before installing.

Reworking valves

Valves must not be reworked. Only grinding-in (lapping) is permitted.

WARNING!

Note precautions required when disposing of sodium-cooled exhaust valves ⇒ [Page 15-87](#) .

Valve guides, checking

When repairing engines or cylinder heads with leaking valves, it is not sufficient to reface the valve seats and replace the valves. The valve guides must also be checked for wear. This is particularly important on high-mileage engines.

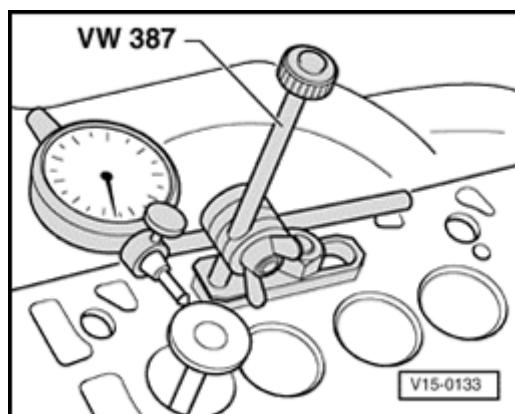

A

- Insert valve into valve guide so that end of valve stem is flush with end of guide. The valve stems have different diameters, so only use an inlet valve in an inlet guide and an exhaust valve in an exhaust guide.
- Measure amount of rock.

Wear limit

Inlet valve guide	Exhaust valve guide
0.8 mm	0.8 mm

If the wear limit is exceeded, replace cylinder head.

Valve seats, reworking (refacing)

Notes:

- ◆ *The valve seats should only be reworked just enough to produce a good seating pattern.*
- ◆ *Calculate the maximum permissible reworking dimension before reworking.*
- ◆ *If the reworking dimension is exceeded, the function of the hydraulic lifters can no longer be guaranteed and the cylinder head should be replaced.*

Calculating maximum permissible reworking dimension

- Insert valve and press firmly against valve seat.

Note:

If the valve is to be replaced as part of a repair, use a new valve for the calculation.

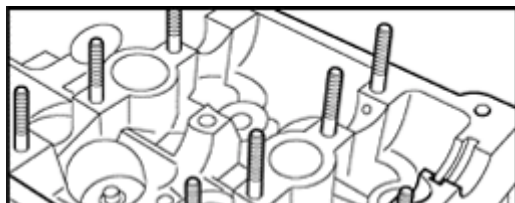

A

- Measure distance between end of valve stem and top surface of cylinder head (illustration shows a 4-valve head).
- Calculate maximum permissible reworking dimension from measured

distance and minimum dimension.

Minimum dimensions		
Outer inlet valve	Center inlet valve	Exhaust valve
32.2 mm	33.2 mm	33.0 mm

Measured distance minus minimum dimension = maximum permissible reworking dimension.

Example	
Center inlet valve	
Measured distance	33.0 mm
Minimum dimension	- 32.2 mm
Maximum permissible reworking dimension	= 0.8 mm

Note:

If the measured distance is less than the minimum dimension, repeat the measurement with new valves, or replace cylinder head.