



# **Montageanleitung**

*Assembly instructions*

**ABT-Heckflügel**

**Art.-Nr.: 8S00 8004 140**

*ABT-rear wing*

*Order no.: 8S00 8004 140*

## Assembly Instructions for ABT Rear Wing



ABT Audi TT\_8S0 (Coupe, MJ 2015) with mounted ABT rear wing

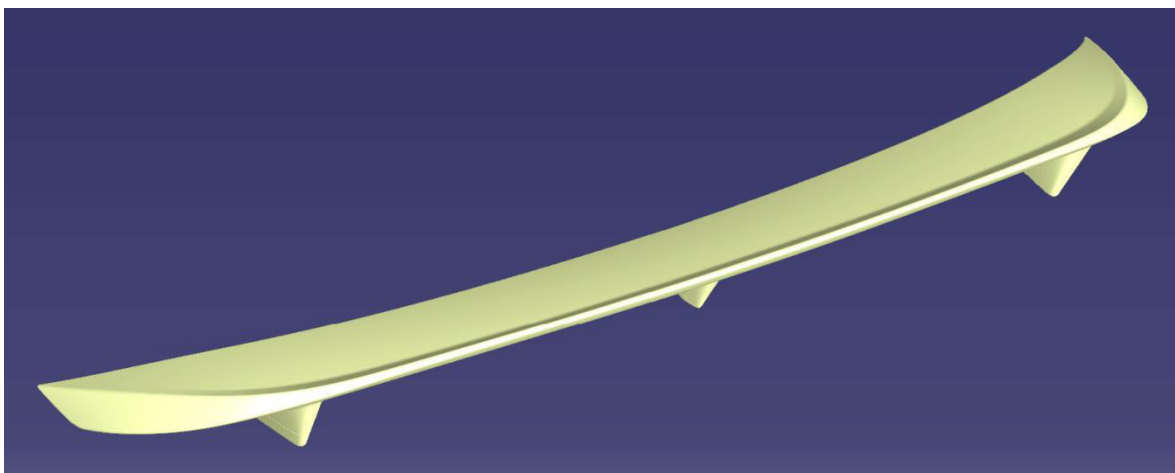

Isometric representation of the ABT rear wing

**Scope of delivery:**

Quantity	Description
1	ABT rear wing
1	Fastening angle, left (for fixing the serial spoiler)
1	Fastening angle, right (for fixing the serial spoiler)
2	Water collector (for serial water drain hose)
4	Screw M6x22mm, flat head, (for fixing the serial spoiler)
13	Nut, self-locking, M6 (for fixing the serial spoiler seating)
4	O-ring, 10.78x2.62mm (for sealing the fastening angles)
9	Screw M5x16mm (for fixing the ABT rear wing and fastening angles)
4	Washer 5.3x20x1.25mm (for fixing the ABT rear wing)
4	Washer 5.3x15x1.25mm (for fixing the fastening angles)
2	Rubber plug Ø14mm; (for fixing the spoiler seating)
1	Drill jig
1	Assembly Instructions
1	General type approval (ABE)



**Note:** For the assembly of the ABT rear wing, it is necessary to condition the vehicle as well as the parts to room temperature (minimum +15°C). Parts and/or vehicles not conditioned adequately can cause serious problems when it comes to bonding and adhesion.



**Attention:** The adhesive which is required for the assembly of the ABT rear wing is not included in delivery. Use only adhesive mentioned in the parts certificate/ABE. Non-observance may lead to the expiration of the general operating licence of the vehicle as well as to the loss of insurance cover and / or may lead to prosecution! The approved adhesives can be ordered as complete adhesive set (adhesive and primer) at Volkswagen/Audi, article number 000.071.785 / 00A.071.785, or at ABT Sportsline either as single tubes (article number ANN 800 009) or as adhesive set (article number ANN 800 019). **For assembling the provided parts, one adhesive set or one tube of adhesive is required.** The primer included in the adhesive set is not needed for the assembly. These assembly instruction only refer to the above mentioned adhesive set.



**Attention:** After assembling the ABT rear wing, do not move the vehicle faster than walking pace for 12 hours. Do not drive faster than 100 km/h until the adhesive has completely hardened (approx. after 48 h).



**Attention:** According to these assembly instructions, the folding function of the serial rear spoiler must be decommissioned for the assembly of the ABT rear wing. The folding function in connection with the ABT rear wing is not permitted!  
The serial drive motor remains in the vehicle and must be electrically connected to avoid error messages.  
Making changes to the program of the serial spoiler is not necessary.

## Assembly Instructions

**Installation time:** approx. 3.5h (without painting)



**Attention:** Before installing, please read the assembly instructions carefully and completely! It includes important details and information which must be followed before and during the installation and which help to avoid misunderstandings. ABT Sportsline recommends a specific dealer's workshop for all assembly work. In case of doubt, please feel free to contact our technical service at +49 (0)831 57140-905.

1. Check if all parts are undamaged and delivery is complete by means of the parts list **before** painting and installing.
2. Remove the lower interior lining of the tailgate. Proceed as described in the current version of the Audi guidelines.
3. Cut out the provided drill jig along the marked lines. Break through the 5 markings for the bore holes with a pointed item (e.g. scriber).
4. Position the drill jig on the serial spoiler and transfer the 5 bore holes onto the serial spoiler by means of a clearly visible, insoluble pen.
5. Check if the ABT rear wing accurately fits to the car. If necessary, adjust gently with appropriate tools. In case of doubt, please feel free to contact our technical service at +49 (0)831 / 57140-905.
6. Paint the ABT rear wing according to the painting instructions on page 12.
7. Extend the serial rear spoiler. Please follow the vehicle owner's manual!
8. Unscrew the screws - arrows - and remove the serial spoiler (fig. 1).  
**Note:** Fix the adjustment elements at the spoiler (with e.g. adhesive tape).

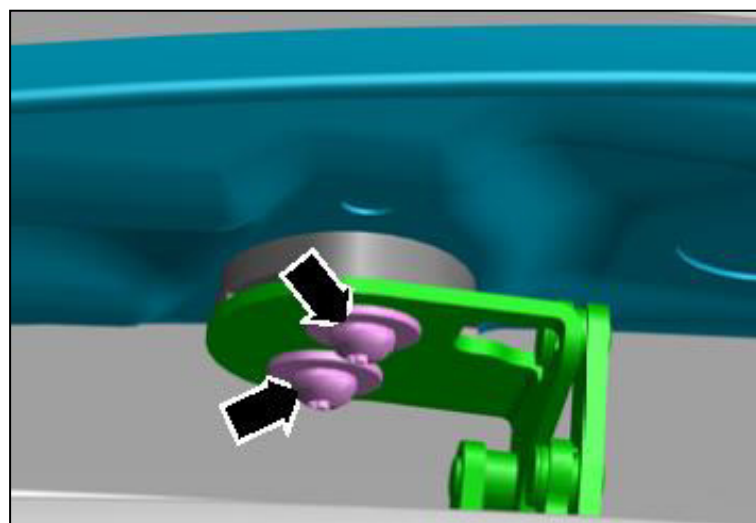

Fig. 1: Disassembly of the serial spoiler

9. Unclip both water collectors -1-. Hereto unlock the clips in indicated direction and press the collectors downwards (fig. 2).

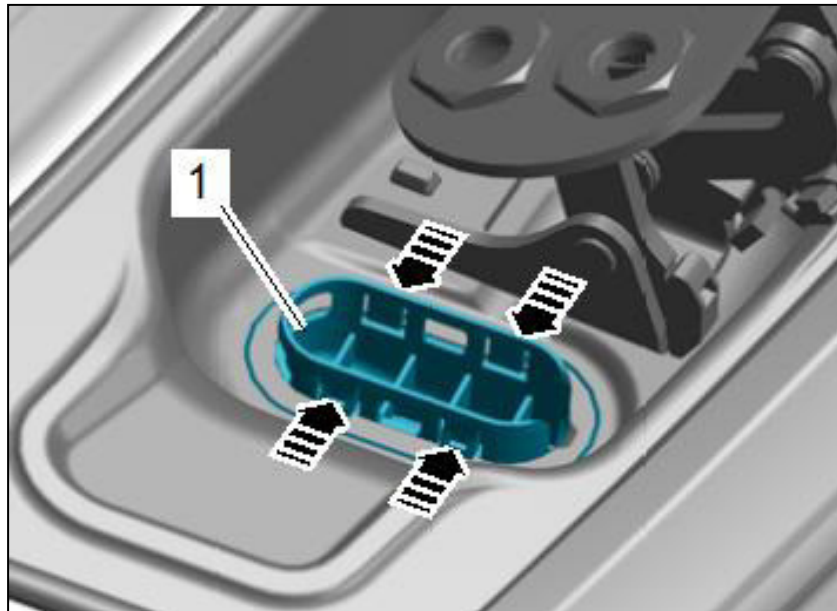

Fig. 2: Unclipping of water collectors

10. Disconnect the electrical plug-in connections -arrow- of the drive motor (fig. 3).

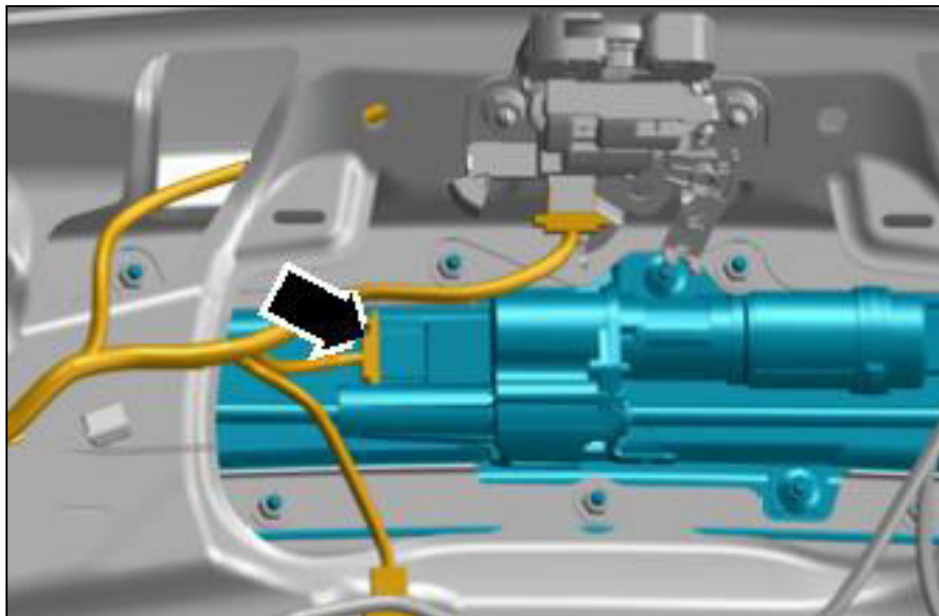

Fig. 3: Disconnect the electrical plug-in connection

11. Remove the nuts 1-13 and remove drive unit and drive base plate (fig. 4).

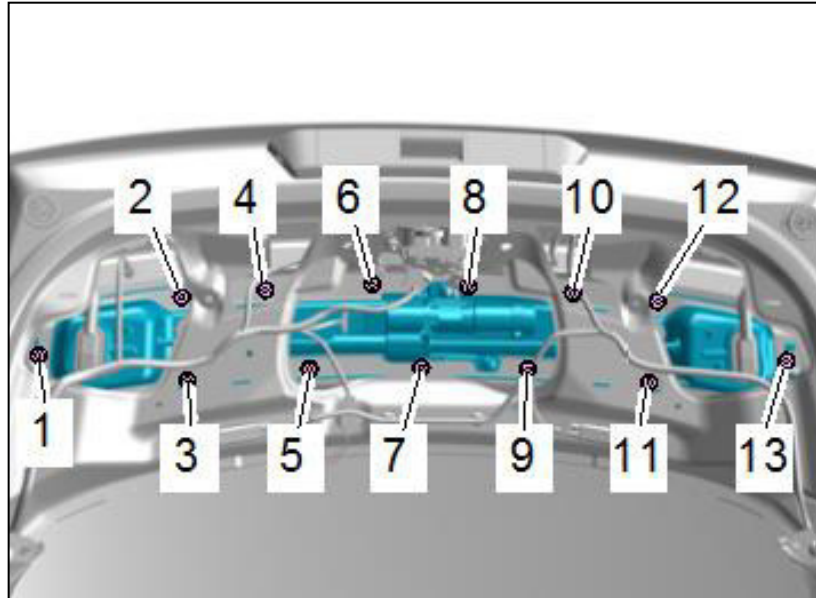

Fig. 4: Disassembly of drive unit and drive base plate



12. Cut the pressed coupling sleeve between the drive unit and the lifting mechanism (fig. 5).  
**Attention:** Do not damage the sealing of the drive base plate! Those are not replaceable!  
 Damages to the corrosion protection must be repaired professionally by all means!



Fig. 5: Severed coupling sleeve at drive motor  
 (for better clarity shown disassembled)



13. Remove both lifting mechanisms (fig. 6, circles).  
**Attention:** The drive motor must not be disassembled!



Fig. 6: Fastening nut of one lifting mechanism (circles)

14. Attach the provided rubber plugs -circle- with an appropriate, permanently elastic sealant to the bore holes of the drive shaft (fig. 7).



Fig. 7: Assembled rubber plug (circle)



15. Insert the provided O-rings into the intended recesses of the fastening angles (fig. 8).  
**Tip:** In order to facilitate the assembly of the fastening angles, we recommend to fix the O-rings with a bit of permanently elastic sealant.

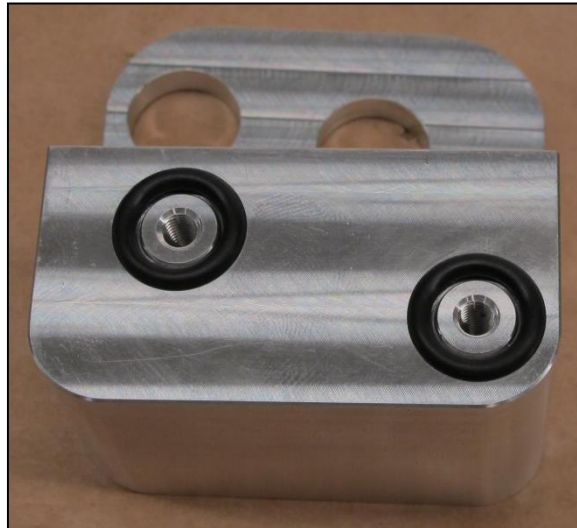

Fig. 8: O-rings for sealing the fastening angles

16. Attach the fastening angles by means of the provided screws M5x16mm and the washers Ø5.3x15mm instead of the lifting mechanisms (fig. 9, tightening torque 6Nm). Use a medium-strength thread locking (e.g. Loctite 243).



Fig. 9: Mounted fastening angle (left side shown;  
right side analog)





17. **Attention:** Exchange the water collectors against the collectors included in delivery (fig. 10). Non-observance can lead to leakages in the trunk!

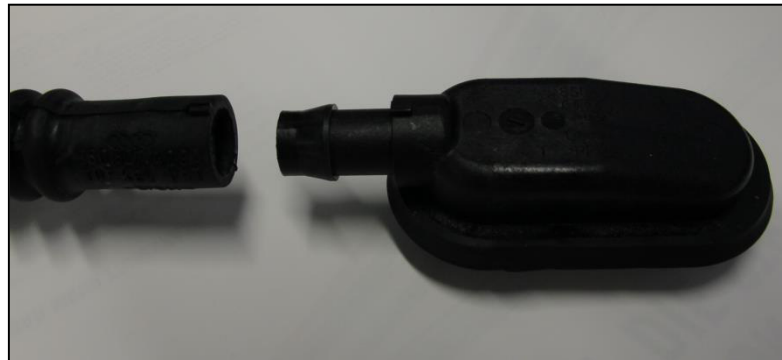

Fig. 10: Exchanging of water collector



18. **Attention:** Reattach the drive base plate. Please use the provided self-locking nuts. You are advised to keep to the proposed scheme shown in fig. 4 (page 6). (tightening torque 2Nm). Non-observance can lead to leakages!



**Note:** Exceeding the mentioned tightening torque can demolish the threaded bolts!  
**Important:** The water collectors may not be assembled at that moment!

19. Lay the serial spoiler onto an appropriate underlay and center punch at the marked positions.  
 20. Drill the attachment holes for the ABT rear wing with a Ø6mm drill. Deburr the bore holes thoroughly.



21. **Attention:** The serial spoiler is double-walled. To avoid waviness of the serial spoiler when screwing the ABT rear wing, the hollow space of the serial spoiler close to the screw connections must be filled painstakingly with firmly hardening adhesive (e.g. Würth 2K-adhesive "fast")!  
 22. Remove the protective foils from the gluing surfaces of the ABT rear wing (fig. 11, arrow). If necessary, clean the threaded inserts.

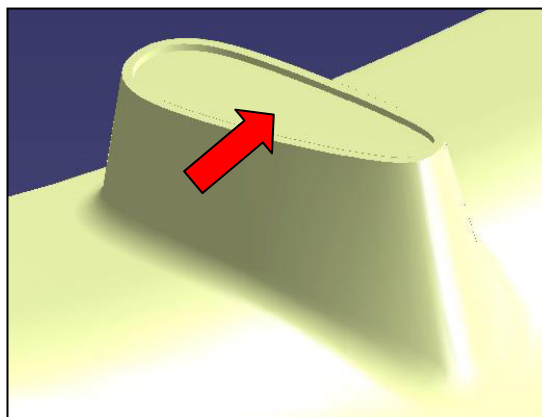

Fig. 11: Gluing surface (arrow)

23. Thoroughly roughen the gluing surfaces of the ABT rear wing down to the basic material by means of the abrasive paper included in the adhesive set. Remove swarf painstakingly.



**Attention:** The gluing surfaces must be completely free of paint and priming coat residues!

24. Clean the gluing surfaces of the ABT rear wing thoroughly by means of the cleaning agent included in the adhesive set. Then let the gluing surfaces air dry for approx. 5 minutes.

25. Thoroughly clean the gluing surfaces of the serial spoiler by means of the cleaning agent included in the adhesive set.

26. Apply adhesive, included in delivery, evenly at a width of approximately 6-7 mm onto the prepared gluing surfaces of the ABT rear wing.



27. **Attention:** After applying the adhesive, only 10 minutes time is left to attach the parts to the vehicle. Follow also the instructions of the adhesive manufacturer on the packing. On request, the newest Safety Data Sheet for the recommended adhesive can be inquired from the manufacturer.

28. With the help of a second person, position the ABT rear wing according to the bore holes on the serial spoiler.

29. Fix the ABT rear wing by means of the provided screws M5x16mm and the washers Ø5.3x20mm on the serial spoiler (tightening torque 6Nm).

30. Remove possibly discharging adhesive with a soft cloth soaked with cleaning agent. Hardened adhesive can only be removed mechanically.



31. **Tip:** ABT Sportsline recommends to fill the constructional small gap between car body and ABT rear wing with remaining adhesive to provide for a harmonic transition between the parts. Hereto apply a bit of adhesive onto a cloth soaked with a mild cleaning agent (e.g. cleaner provided in the adhesive set) and rub the adhesive into the gap. If necessary repeat this work step until the gap is completely filled with adhesive.

32. With the help of an assistant, insert the serial spoiler into the tailgate. Check the adjustment to the surrounding chassis. If necessary, adjust according to the Audi guidelines.

33. Attach the serial spoiler to the vehicle. Use the provided, self-locking screws M6x22mm (tightening torque 8Nm).



34. Assemble the water collectors carefully to the drive base plate.

**Attention:** ABT Sportsline recommends to check the tightness of the tailgate in the assembly area before continuing the assembly of the ABT rear wing. Hereto use relaxed water (tap water, with a bit of cleaner).

35. Reconnect the plug of the drive motor.

36. Attach the lower tailgate lining according to the Audi guidelines.

37. Read out the event memory and delete all data referring to the rear spoiler.



38. **Legal hint:** ABT Sportsline is not liable for damages of all kinds resulting from faulty assembling and/or from mishandling of the ABT rear wing as well as of the provided or recommended installation material. Deviations in the above mentioned assembly steps, especially the use of other than the provided or recommended installation material, void the general type-approval of the vehicle and may lead to prosecution.

## Painting Instructions for Primed Body Parts made of the Basic Material <PUR>



**Note:** ABT Sportsline recommends having all paint work done by a competent paint shop.



**Attention:** During all work steps, all body parts must be stored non-distorted and under consideration of later assembly circumstances. ABT Sportsline assumes no liability or responsibility for deformed parts due to inappropriate storing during assembly or painting! Make certain during painting that the type label remains readable.

14. It is important to check the fitting accuracy of unpainted body parts on the vehicle before painting. If necessary, slightly adjust with appropriate tools. In case of doubt, please feel free to contact our technical service at (+49 (0)831 57140-905).
15. Check for completeness and a tight fit of the original attached protective films on the gluing surfaces. If necessary complete and exchange missing or loose covers.
16. Store the body part distortion-free on appropriate paint trestles corresponding to the later mounting position.
17. Grind the priming coat thoroughly with abrasive paper (wet: P800-P1000 or dry: P320-P360). Avoid to grind into the factory-attached priming.



18. **Note:** Necessarily squirt areas which are grinded through with appropriate plastic glue primer according to the manufacturer's instructions.

19. Smooth the visible edges, if necessary.

20. Fill possibly appearing pores with appropriate material.



21. **Tip:** In case of light metallic colours, regrind the body part with following grit size: wet: P1200 or dry P400.

22. Clean the body part thoroughly with appropriate cleaning agent (e.g. silicone remover) and let it air dry thoroughly.

23. Dilute the base coat paint according to the manufacturer's instructions and apply it onto the prepared body part. Observe the prescribed airing time of the varnish manufacturer.

24. Elasticise the 2K acrylic clear coat by adding approximately 20% plasticiser, then mix it with the required amount of hardener according to the manufacturer's instructions.

25. Apply clear coat onto the body part according to the manufacturer's instructions.

26. Let the wet paint dry at approximately 35°C.

Printing errors and technical alterations/news excepted!



ABT Sportslin GmbH  
Daimlerstraße 2  
87437 Kempten / Allgäu

[www.ABT-sportslin.de](http://www.ABT-sportslin.de)