

A5 **S5**





**Has as much in common  
with art as it does performance.**

The Audi A5 is a study in the art of nuance. Nuance, of course, with a decidedly assertive side. The A5 creates a dominating presence with its low, wide stance and its muscular proportions. A closer look reveals meticulous attention has been paid to exterior design details, like the impactful, long-life LED daytime running lights and taillights, the distinctive singleframe® grille and the LED turn signals seamlessly integrated into the sideview mirrors. The Audi A5 is a flawless execution of what a coupe should be. A fact not lost on *AUTOMOBILE Magazine*, as the A5 received the prestigious 2009 *AUTOMOBILE Magazine* Design of the Year award.



**Designed around the  
most important component.**

The Audi A5 makes the driver central to everything. Starting with a comfortable, driver-oriented cockpit and naturally placed MMI® controls, the A5 interior ensures that convenience and comfort are always within reach. With a high-mounted 6.5" full-color MMI® screen, the Audi A5 creates a seamless integration between intuitive functionality and sublime luxury. The impeccable fit and finish is completed with the finest materials by way of the optional Milano leather heated seats with driver side memory.

**Progress means fast alone is not enough.**

Never comfortable with "good enough," Audi set out to do something extraordinary: Build an engine more powerful while at the same time making it more efficient. That's exactly what FSI® technology unleashes. The 3.2 liter V6 FSI® engine delivers 265 hp in tandem with a reputable 26 MPG\* highway. Also available is the renowned 2.0 liter TFSI® engine, which produces a pulse-quickenning 211 hp with a best-in-class 30 MPG\* highway. In other words, producing the power of a six-cylinder while offering the efficiency of a four-cylinder. This is progress you can feel.



\* EPA estimate: 17/26 city/highway MPG. \* EPA estimate: 22/30 city/highway MPG. Your mileage will vary.

Audi A5 3.2 Premium Plus

**This notion of superb performance  
perfectly executed.**

The ability of the A5 to create the perfect driving experience is traced to a few distinct elements found only in an Audi. The legendary control of quattro® all-wheel drive is the first in a list of dominating performance features. This latest generation of quattro® offers a rear torque bias of 40:60, ensuring true sports coupe handling. The five-link front and trapezoidal-link rear suspension optimize wheel placement, whether driving in a normal fashion or more assertively. With the available S line Sport Package and the included 19" wheels, handling is stiffer, offering an exceptionally sporty ride.

The optional Audi drive select provides the ultimate in handling customization with up to 27 different combinations of vehicle performance settings. Audi drive select allows the driver a choice of four distinct modes, ranging from the performance-oriented Dynamic setting to the more pliant ride of Comfort. The handling of the Audi A5 is further enhanced with Servotronic® speed-sensitive steering, which automatically scales steering input based on the vehicle's speed, helping ensure optimum performance regardless of the situation.





### The answer to “What if...?”

Start by eliminating boundaries, and it's quite likely you will wind up with something like the Audi A5 interior. It offers a number of features that add a new dimension to luxury. And it all starts with the MMI® operating system. As the nerve center of the Audi A5, the MMI® enables the driver to easily control and customize a number of features. For instance, you can plan your route thanks to the available integrated MMI® navigation system. The available voice control feature, activated via the multifunction steering wheel, allows control of everything from the radio and your iPod® to your Bluetooth®-enabled phone. Even adjustments to Audi drive select can be made through the MMI® operating system.

Luxury is also having access to advanced technological innovation that helps keep you out of harm's way. For instance, driver assist programs, like Audi side assist, alert the driver to vehicles in the driver's blind spot. And adaptive cruise control, when activated, automatically decelerates or even applies the brakes if the Audi A5 approaches cars within the driver's preset distance.

**The power of innovation  
is the power of technology.**

Countless performance innovations are found in nearly every aspect of the Audi A5. We are never content until these innovations change the way you experience the road. Take the Audi valvelift system, for instance. By optimizing air intake and exhaust valving, peak performance is ensured throughout the powerband. The result is an engine that delivers high levels of torque essential for responsive acceleration at all times. With the available 3.2 liter FSI® V6 producing 243 lb-ft. of torque, the valvelift system increases fuel efficiency. And with the standard 2.0 liter TFSI®, the system adds an exceptional 258 lb-ft. of torque for immediate acceleration. Couple that with quattro® all-wheel drive, and you experience the perfect combination of enhanced traction and handling with state-of-the-art power.





**We thought of you, which means  
we've thought of everything.**

Audi has always held firm the belief that prevention is the best safety feature of all. And the Audi A5 offers an abundance of features designed to help keep you out of harm's way. For instance, one unique feature of the Audi A5 is the Electronic Stabilization Program [ESP®]. It helps keep the A5 traveling in its intended direction by utilizing ABS, the traction control of ASR and the electronic brake force distribution of EBD. Another innovative feature is brake disc wiping. The system gently pulses the brakes to dissipate water build-up, keeping the brake discs as dry as possible, allowing for quicker, more effective braking.

Additionally, the Brake Assist system comes into play when an emergency situation is encountered. A sensor instantly detects the attempt at full braking and transmits a signal summoning full brake pressure from the hydraulic booster. The advantage: Braking distance is significantly reduced.

And when prevention isn't enough, the extremely rigid steel body acts as one of the primary safety systems of the Audi A5, creating an ultra-high-strength cocoon for the occupants. Finally, occupants are offered even more protection by way of six standard airbags\*.

\* Airbags are supplemental restraints only and will not deploy under all crash circumstances. Always use safety belts and seat children in the rear, using restraint systems appropriate for their size and age. This is a dramatization and does not depict what will happen in an accident. All bags will not inflate in real-world accidents, and if multiple bags do deploy, they will be in various stages of inflating/deflating and will never all be inflated at the same time.



### The nemesis of compromise.

From the moment the signature LED daytime running lights spring to life, the message becomes clear: The S5 is designed and built for luxury and speed. A pure coupe through and through, the S5 embodies every detail of the exceptionally designed A5. Continued with a series of sport-inspired elements, like quad-tip exhaust, Aluminum Optic mirrors and blades, the S5 enhances its classic proportions with a wide stance that emphasizes its stature as the pinnacle of performance coupes.



### A worthy sequel to a striking exterior.

The interior of the Audi S5 is just what you would expect after seeing the performance-enhanced exterior. Special Silk Nappa leather S5 sport seats feature integrated headrests and pronounced side bolsters for more assertive driving. And available Carbon Fiber accents are tastefully integrated throughout, reinforcing an unwavering commitment to performance.



### Performance in all of the right places.

The Audi S5 offers enhancements that make it a coupe singularly focused on total performance. It all starts with a high-revving 4.2 liter V8 FSI® engine effortlessly churning out 354 hp and 325 lb-ft. of torque, making it capable of reaching 60 MPH from a standing start in just 4.9 seconds.

With no shortage of power, the S5 has handling to match - integrated lightweight aluminum suspension components reduce unsprung weight and increase rigidity, offering a more responsive driving experience. Its potential is fully realized with standard 19" wheels and summer performance tires\* designed for precise handling. When it comes to performance, the Audi S5 is all about exceeding expectations.

**Performance fueled by  
unconventional thinking.**

What would it be like to have a sports coupe that handles like a sportscar and has the traction and directional stability of all-wheel drive? Quite simply, that is the Audi S5. With the latest generation of quattro® with Sport Rear Differential, the S5 offers unmistakable performance driving with a 60 percent distribution of torque to the rear wheels. At the same time, torque varies between the outside rear wheels for improved cornering. The quattro® all-wheel drive system responds instantaneously and does not require you to engage it. It is always on, providing enhanced driver confidence. These innovations give the S5 handling that has to be experienced to be believed.





**1. Leather seating surfaces** | Aside from offering superior quality and design, the leather seating surfaces offer pronounced shoulder and side support.

**2. 18" ten-spoke wheels with 245/40 all-season tires** | The ten-spoke alloy wheels' progressive design is matched to the dynamic elegance of the A5 model. The lightweight alloy complements the excellent driving dynamics.

**3. Auto climate control** | The climate is easily controlled through the center console, while a light sensor on the dashboard adjusts the system based on the sun's intensity.

**+ Audi concert radio with ten speakers and SIRIUS® Satellite Radio** | Audi concert radio features the Audi Sound System with 180 watts of power and ten total speakers, including two in each door, a subwoofer and a center fill speaker. It also offers a CD player, auxiliary input and an SD® card slot with MP3 capability. The Radio Data System [RDS] on the color screen displays several types of FM radio information, as well as SIRIUS® Satellite Radio information. And the Graduated Audio Level Adjustment [GALA] helps ensure optimal volume levels as cabin noise increases with speed.

Features listed are standard on the Premium model unless otherwise noted.

**+ FEATURE NOT SHOWN**

**4. Leather-wrapped, three-spoke, multifunction steering wheel |**

The leather-wrapped, three-spoke design has a sporty look and feel. The multifunction steering wheel provides easy access to Bluetooth®-enabled phone, audio volume and seek functions.

**5. Power adjustable, heated exterior mirrors with integrated LED turn signals |**

The exterior rearview mirrors are electronically adjustable, heated to help prevent fogging and house the integrated LED turn signals.

**6. Split folding 50/50 rear seatbacks |**

Rear seats can be folded together or individually for increased flexibility and space. When the rear seats are folded, a full pass-through from the trunk is available. When unfolded, the rear seats comfortably accommodate two adults.

**+ Power front seats with driver lumbar support |**

The power front seats allow the driver and passenger to electronically adjust the seats' forward/backward position, height, angle of seat cushion and seatback and the driver's lumbar support.

**+ Halogen headlights with daytime running lights |**

Halogen headlights help enhance safety by illuminating a wider section of the road.



Features listed are standard on the Premium model unless otherwise noted.

+ FEATURE NOT SHOWN

## A5 Premium Plus



## A5 Premium Plus

- 1 **Audi xenon plus headlights with LED daytime running lights** | These headlights produce about twice as much light as comparable halogen headlights and help make night driving, particularly in poor weather, less tiring for the driver's eyes with improved visibility. LED daytime running lights also consume less energy than conventional daytime running lights.
- 2 **LED taillights** | LED lights are superior to conventional bulbs with their activation speed and their long service life. They can last an entire vehicle lifetime, consume up to 50 percent less energy and take up less space.
- 3 **HomeLink® and Bluetooth®** | HomeLink® is integrated into the overhead controls and uses a simple three-button system that can control garage doors, gates and even lights in the home. The Bluetooth® hands-free phone interface allows the pairing of a Bluetooth®-enabled mobile phone with the vehicle, and includes access to the phonebook within the driver information display of the instrument panel. For specific compatibility and operation, refer to [audiusa.com/bluetooth](http://audiusa.com/bluetooth) or contact your local Audi dealer for the latest listing of compatible phones.
- 4 **Audi music interface** | The Audi music interface offers intelligent integration with the iPod®. Any iPod® Generation 4 and higher [iPod®, iPod® nano, iPod® photo] may be connected through the glove box, and full iPod® controls are available through the MMI® screen.
- + **Heated front seats** | The multilevel seat heating system is designed to heat the entire surface of the seat; warming is initiated with a convenient button.
- + **Three-zone automatic climate control** | Both driver and front passenger, as well as the occupants of the rear seats, can select their required temperature and distribution of air individually for their particular seating area.

Features listed are standard on the Premium Plus model unless otherwise noted.

+ FEATURE NOT SHOWN

**5 Bang & Olufsen® Sound System** | This unrivaled sound system combines state-of-the-art technologies that include Digital Signal Processing [DSP] and ICEpower digital amplification with a detailed study of the Audi interior. More than a sound system built into a car, the system is the ultimate driving and listening experience, a virtual concert hall on wheels.

**6 Audi MMI® Navigation plus** | Audi MMI® Navigation plus features a 7", full-color LCD screen and MMI® control logic. The Audi A5 comes equipped with the latest generation of MMI®, powered by a 40-GB hard drive and an NVIDIA® processor to enhance graphics. This generation of MMI® offers 3D topography, including the buildings in many cities. A color driver information system, real-time traffic, and navigation through audible route guidance and graphics are included.

**7 Audi advanced key** | With Audi advanced key, the car can be unlocked and started without removing the key from a pocket or purse. The steering can be released and the ignition turned on electronically, all without inserting the key into the ignition.

**+ Memory for driver seat and outside mirrors** | With the touch of a button, the advanced memory system automatically adjusts the seat's forward/backward position, height, lumbar support, angle of seat cushion and seatback and outside mirror settings based on the key that is being used.

Features listed are standard on the Prestige model unless otherwise noted.

+ FEATURE NOT SHOWN





## A5 Packages



### A5 S line Package

Available on A5 Prestige only

- 1 **Sport seats** | The sport seats offer greater lateral support, thanks to more prominent side sections. The seat functions include electric lumbar support for both front seats and are accented by leather upholstery with perforated Alcantara® inserts and contrast Silver stitching.
- 2 **S line steering wheel** | The S line Package includes a multifunction, three-spoke, leather-covered steering wheel with contrast-color stitching and the S line badge. On vehicles equipped with automatic transmissions, the steering wheel includes shift paddles for quick, driver-selected gear changes.
- 3 **Brushed Aluminum inlays from quattro® GmbH** | S line interior touches are anchored with Brushed Aluminum inlays throughout the cockpit and extend into the rear, including doorsill inlays with the S line badge. These contrast with an elegant Black headliner that matches the interior.
- + **S line front and rear bumpers** | The unique S line bumpers accentuate the sporty and powerful exterior of the A5.
- + **19" five-Y-spoke wheels with 255/35 summer performance tires\*** | The 19" five-Y-spoke wheel option adds an athletic feel. The progressive design is matched to the dynamic elegance of the A5.
- + **Sport suspension** | For those who plan to drive in a more sporty fashion, the S line Package includes a firmer suspension. The new five-link front and trapezoidal-link rear suspension has been specially sport-tuned to perform without sacrificing passenger comfort.

### A5 Driver Assist Package

Available on A5 Prestige only

- 4 **Audi side assist** | Audi side assist system helps monitor the blind spot areas when changing lanes, as well as fast-approaching vehicles, at a range of about 150 ft. to the rear of the car. If Audi side assist identifies another vehicle, it informs the driver via LED lights in the exterior mirror.
- + **Rear parking sensors with rearview camera** | Ultrasonic sensors measure the distance from the rear bumper to obstacles while intermittent audible tones indicate the distance to the driver. The rearview camera aid helps the driver see objects behind the vehicle when backing up.

\* See page 34 for important safety information regarding summer performance tires.

+ FEATURE NOT SHOWN

### A5 Navigation plus Package

Available on A5 Premium Plus only

**5 Audi MMI® Navigation plus** | Audi MMI® Navigation plus features a 7", full-color LCD screen and MMI® control logic. The Audi A5 comes equipped with the latest generation of MMI®, powered by a 40-GB hard drive and an NVIDIA® processor to enhance graphics. This generation of MMI® offers 3D topography, including the buildings in many cities. A color driver information system, real-time traffic, and navigation through audible route guidance and graphics are included.

**6 Audi parking system** | The rearview camera offers a real-time view of the rear parking area, while the rear ultrasonic parking sensors measure the distance to the nearest object.

**+ Voice control** | Included with the navigation system are five language settings and a voice control system that can be used to operate the most important navigation, radio and hands-free mobile phone functions by speaking the necessary commands.

**+ Eight-color LCD driver information display** | Conveniently located in the instrument panel, this user-friendly interface includes radio, telephone and navigation data, as well as information on the current operating status, which monitors the condition of vehicle components.

### A5 Sport Package

Available on A5 Premium Plus and Prestige only

**7 19" five-Y-spoke wheels with 255/35 summer performance tires\*** | The 19" five-Y-spoke wheel option adds an athletic feel. The progressive design is matched to the dynamic elegance of the A5.

**8 Sport seats** | The sport seats offer greater lateral support thanks to more prominent side bolsters. The seat functions include electric lumbar support for both front seats, extendable thigh support and electric head restraint.

**+ Sport suspension** | For those who plan to drive in a more sporty fashion, the Sport Package includes a firmer suspension. The new five-link front and trapezoidal-link rear suspension has been specially sport-tuned to perform without sacrificing passenger comfort.

**+ Shift paddles** | Models equipped with the Sport Package receive shift paddles on the three-spoke steering wheel that allow effortless, race-inspired gear shifting and keep the driver's hands on the steering wheel. [Available with Tiptronic® automatic transmission only]

\* See page 34 for important safety information regarding summer performance tires.

+ FEATURE NOT SHOWN



## A5 Options



## A5 Options

**1 Bang & Olufsen® Sound System** | The Bang & Olufsen® Sound System includes 14 speakers with 505 digitally amplified watts and surround sound reproduction. Microphone-based noise compensation ensures optimum sound under varying road conditions and speeds. [Option on Premium Plus only]

**2 Audi drive select** | Audi drive select controls the vehicle's adaptive suspension, dynamic steering, transmission shift characteristics and engine response. The system offers four distinct drive configurations: Comfort, Automatic, Dynamic and Individual. [Option on Prestige only]

**3 Genuine Milano leather seats** | This leather option offers a particularly soft and supple texture that ensures a luxuriously comfortable ride. [Option on Premium Plus and Prestige only]

**4 Front spoiler with blade insert** | An Audi-designed styling component creates a dynamic lowered appearance with a front spoiler and blade. [Available on A5 only]

**5 Rear spoiler** | A trunk lip spoiler adds a distinctive sporty flair to your A5/S5.

**6 Rear diffuser with blade insert** | This Audi-designed styling component adds an aggressive edge to the A5. [Available on A5 only]

**7 19" five-arm hollow spoke wheels** | Aside from being extremely lightweight, these alloy wheels feature wide spokes that create a dramatic look, whether parked or in motion.

**8 Side sills** | The pronounced side sills reinforce the sporty look of the A5 by giving it a lower, more aggressive look. [Available on A5 only]

**+ 19" 15-spoke wheels** | These wheels make a strong statement with an eye-catching design. All of our alloy wheels are specially engineered to meet the strict tolerances of our Audi original wheels.

**+ Upright Barracuda® bicycle holder** | This bike holder fits 20-80 mm bike frames and is easy to use. It features a molded front wheel well that allows the bike to stand on its own as you easily secure the bike. Lock included. [Must be used in combination with the base carrier bars, which are sold separately]

**+ Ski and snowboard rack** | This rack's rubber-cushioned aluminum bars hold securely. Push-button keyed locks open and close easily. Our smaller standard attachment holds up to four skis or two snowboards. A larger deluxe attachment holds up to six skis or four snowboards. [Must be used in combination with the base carrier bars, which are sold separately]

**+ Polished grille strips** | The polished grille strips accent the distinctive Audi singleframe® grille. Strips attach to the grille with OEM-grade adhesive for long-lasting durability.

+ FEATURE NOT SHOWN



## Dressed for performance.

Your Audi is just that – yours. With a number of available enhancements, including wheels and a special aerodynamic spoiler, your Audi can become your own signature model.

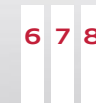



- 1 **Shift paddles** | Shift paddles allow effortless, race-inspired gear shifting and keep the driver's hands on the steering wheel.  
[Available with Tiptronic® automatic transmission only]
- 2 **S5 sport seats** | The unique sport seats offered on the S5 provide greater lateral support thanks to more prominent side bolsters. The seat functions include electric lumbar support for both seats and integrated head restraints. The use of high-quality Silk Nappa leather in the interior of the S5 adds to the elegant, dynamic and sporty driving experience.
- 3 **Audi music interface** | The Audi music interface offers intelligent integration with the iPod®. Any iPod® Generation 4 and higher [iPod®, iPod® nano, iPod® photo] may be connected through the glove box, and full iPod® controls are available through the MMI® screen.
- 4 **Dual exhaust quad tailpipes** | Unique quad oval tailpipes create a rich exhaust note and leave no doubt about the power contained under the hood of the S5.
- + **Brushed Aluminum inlays** | The quality of materials and craftsmanship of the S5 interior is highlighted by elegant and sporty Brushed Aluminum decorative inlays extending across the dash and doors.
- + **19" five-double-spoke wheels with 255/35 summer performance tires\*** | The 19" five-double-spoke wheel option is impressive in its stance and design. The wheels come equipped with summer performance tires, which provide improved driving dynamics and superior handling and performance.

Features listed are standard on the Premium Plus model unless otherwise noted.  
\* See page 34 for important safety information regarding summer performance tires.

- 5 **Bang & Olufsen® Sound System** | The Bang & Olufsen® Sound System includes 14 speakers with 505 digitally amplified watts and surround sound reproduction. Microphone-based noise compensation ensures optimum sound under varying road conditions and speeds.
- 6 **Audi advanced key** | With Audi advanced key, the car can be unlocked and started without removing the key from a pocket or purse. The steering can be released and the ignition turned on electronically, all without inserting the key into the ignition.
- + **Audi MMI® Navigation plus** | Audi MMI® Navigation plus features a 7", full-color LCD screen and MMI® control logic. The Audi S5 comes equipped with the latest generation of MMI®, powered by a 40-GB hard drive and an NVIDIA® processor to enhance graphics. This generation of MMI® offers 3D topography, including the buildings in many cities. A color driver information system, real-time traffic, and navigation through audible route guidance and graphics are included.
- + **Voice control** | Included with the navigation system are five language settings and a voice control system that can be used to operate the most important navigation, radio and hands-free mobile phone functions by speaking the necessary commands.



Features listed are standard on the Prestige model unless otherwise noted.

+ FEATURE NOT SHOWN



1



2



3



4

## S5 Options

- 1 **Carbon Fiber inlays** | The Carbon Fiber decorative inlays accent the overall interior excellence of the S5.
- 2 **19" five-tri-spoke wheels with 255/35 summer performance tires\*** | A work of art, these wheels make a dramatic and sporty statement regardless of whether they are moving or motionless.
- 3 **Audi adaptive cruise control** | Adaptive cruise control monitors distance to the vehicle in front via radar sensors and automatically reduces speed, as well as resumes speed to maintain the driver-selected safe distance.
- + **Stainless Steel inlays** | The quality of materials and craftsmanship of the S5 interior is highlighted by sophisticated Stainless Steel decorative inlays extending across the dash and doors.
- + **quattro® with Sport Rear Differential** | quattro® with Sport Rear Differential dynamically varies torque between the rear wheels for enhanced cornering agility.

## S5 Audi Drive Select Package

Available on S5 Prestige only

- 4 **Audi drive select** | Audi drive select controls the vehicle's adaptive suspension, dynamic steering, quattro® with Sport Rear Differential, transmission shift characteristics and engine response. The system offers four distinct drive configurations: Comfort, Automatic, Dynamic and Individual.
- + **quattro® with Sport Rear Differential** | quattro® with Sport Rear Differential dynamically varies torque between the rear wheels for enhanced cornering agility.

\* See page 34 for important safety information regarding summer performance tires.

### S5 Audi Navigation plus Package

Available on S5 Premium Plus only

- 5 **Audi MMI® Navigation plus** | Audi MMI® Navigation plus features a 7", full-color LCD screen and MMI® control logic. The Audi S5 comes equipped with the latest generation of MMI®, powered by a 40-GB hard drive and an NVIDIA® processor to enhance graphics. This generation of MMI® offers 3D topography, including the buildings in many cities. A color driver information system, real-time traffic, and navigation through audible route guidance and graphics are included.
- 6 **Audi parking system** | The rearview camera offers a real-time view of the rear parking area, while the rear ultrasonic parking sensor measures the distance to the nearest object.
- + **Voice control** | Included with the navigation system are five language settings and a voice control system that can be used to operate the most important navigation, radio and hands-free mobile phone functions by speaking the necessary commands.
- + **Eight-color LCD driver information display** | Conveniently located in the instrument panel, this user-friendly interface includes radio, telephone and navigation data, as well as information on the current operating status, which monitors the condition of vehicle components.

### S5 Driver Assist Package

Available on S5 Prestige only

- 7 **Audi side assist** | Audi side assist system helps monitor the blind spot areas when changing lanes, as well as fast-approaching vehicles, at a range of about 150 ft. to the rear of the car. If Audi side assist identifies another vehicle, it informs the driver via LED lights in the exterior mirror.
- + **Rear parking sensors with rearview camera** | Ultrasonic sensors measure the distance from the rear bumper to obstacles while intermittent audible tones indicate the distance to the driver. The rearview camera aid helps the driver see objects behind the vehicle when backing up.

+ FEATURE NOT SHOWN





## A5 Wheel Options

1



2



3



## A5 Wheel Options

**1. 18" ten-spoke wheels with 245/40 all-season tires** | The ten-spoke alloy wheels' progressive design is matched to the dynamic elegance of the A5 model. The lightweight alloy complements the excellent driving dynamics. [A5 Premium]

**2. 18" five-spoke wheels with 245/40 all-season tires** | The refined simplicity of this sporty, classic five-spoke wheel complements the fluid lines of the Audi A5. [A5 Premium Plus and Prestige]

**3. 19" five-Y-spoke wheels with 255/35 summer performance tires\*** | A work of art, these wheels make a dramatic and sporty statement, regardless of whether they are moving or motionless. [Option on A5 Premium Plus and Prestige only]

\* Summer performance tires are designed for optimum performance and handling in warm climates. They are not suitable for cold, snowy or icy weather conditions. If you drive under those circumstances, you should equip your vehicle with all-season or winter tires, which offer better traction under those conditions. We suggest you use the recommended winter or all-season tires specified for your car or their equivalent. These summer performance tires also have a lower aspect ratio that aids performance and handling; however, in order to avoid tire, rim or vehicle damage, it is important that the inflation pressure is regularly checked and maintained at recommended levels. Serious wheel and tire damage may occur if the vehicle is operated on rough or damaged road surfaces, or upon encountering road debris or obstacles. Please also remember in making your selection that, while these tires deliver responsive handling, they may ride less comfortably and make more noise than other choices. Finally, these tires may wear more quickly than other choices. For more information on all of these topics, please consult the owner's manual, your local dealer or call 1-800-FOR-AUDI.

---

**4 19" five-double-spoke wheels with 255/35 summer performance tires\*** | The unique and dramatic profile of these five-double-spoke alloy wheels highlights the progressive looks of the performance-oriented Audi S5. [S5 Premium Plus and Prestige]

**5 19" five-tri-spoke wheels with 255/35 summer performance tires\*** | The boldly distinctive openness of the five-tri-spoke alloy wheels with summer performance tires makes a sporty statement. [Option on S5 Premium Plus and Prestige]

---

4



5



---

\* Summer performance tires are designed for optimum performance and handling in warm climates. They are not suitable for cold, snowy or icy weather conditions. If you drive under those circumstances, you should equip your vehicle with all-season or winter tires, which offer better traction under those conditions. We suggest you use the recommended winter or all-season tires specified for your car or their equivalent. These summer performance tires also have a lower aspect ratio that aids performance and handling; however, in order to avoid tire, rim or vehicle damage, it is important that the inflation pressure is regularly checked and maintained at recommended levels. Serious wheel and tire damage may occur if the vehicle is operated on rough or damaged road surfaces, or upon encountering road debris or obstacles. Please also remember in making your selection that, while these tires deliver responsive handling, they may ride less comfortably and make more noise than other choices. Finally, these tires may wear more quickly than other choices. For more information on all of these topics, please consult the owner's manual, your local dealer or call 1-800-FOR-AUDI.

---

BLACK LEATHER or MILANO LEATHER | ALUMINUM HOLOGRAM INLAY



LINEN BEIGE LEATHER or MILANO LEATHER | ALMOND BEIGE ASH WOOD INLAY\*

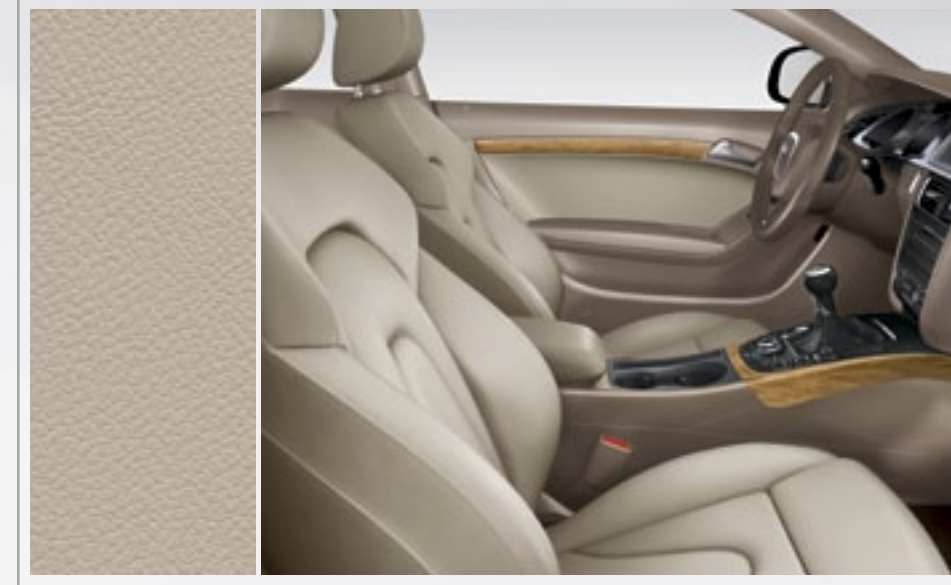

BLACK LEATHER/PERFORATED ALCANTARA® | BRUSHED ALUMINUM INLAY [S line only]



LIGHT GRAY LEATHER or MILANO LEATHER | DARK BROWN WALNUT WOOD INLAY\*



CINNAMON BROWN MILANO LEATHER | NUTMEG LAUREL WOOD INLAY\*



DECORATIVE INLAY OPTIONS

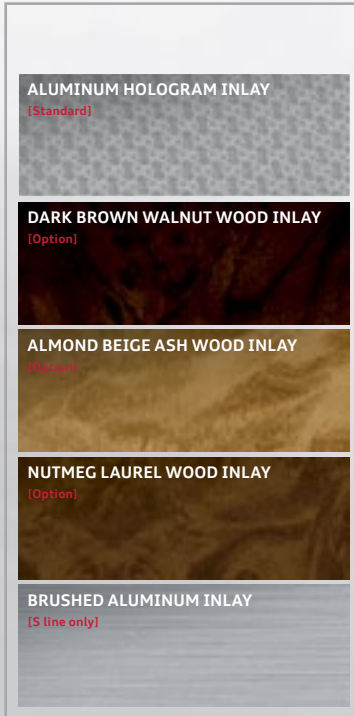

\* Optional inlay shown

BLACK SILK NAPPA LEATHER | BRUSHED ALUMINUM INLAY



MAGMA RED SILK NAPPA LEATHER | GRAY BIRCH WOOD INLAY\*



BLACK SILK NAPPA LEATHER/BLACK ALCANTARA® | STAINLESS STEEL TEXTURE INLAY\*



DECORATIVE INLAY OPTIONS

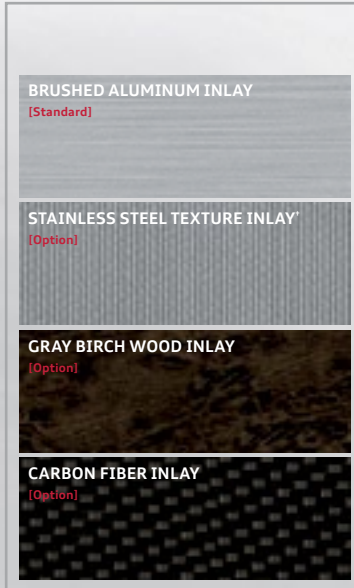

PEARL SILVER SILK NAPPA LEATHER | STAINLESS STEEL TEXTURE INLAY\*\*



TUSCAN BROWN SILK NAPPA LEATHER | CARBON FIBER INLAY\*



BLACK SILK NAPPA LEATHER/SILVER ALCANTARA® | STAINLESS STEEL TEXTURE INLAY\*



\* Optional inlay shown  
 \*\* Includes Piano Black inlay on center console

Audi A5 | S5 Make Yours.



A5 Monza Silver<sup>1</sup> METALLIC<sup>‡</sup>

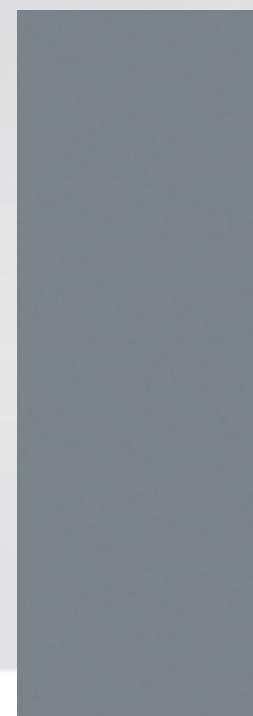

A5 Misano Red<sup>‡</sup> PEARL EFFECT<sup>‡</sup>

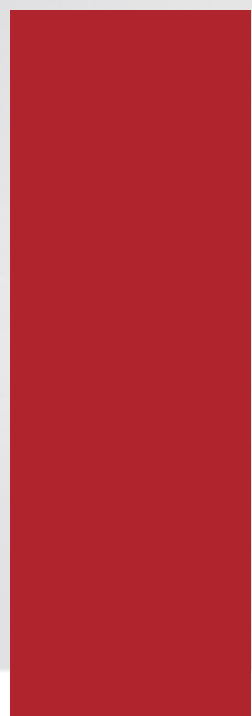

A5 Sahara Silver<sup>1</sup> METALLIC<sup>‡</sup>

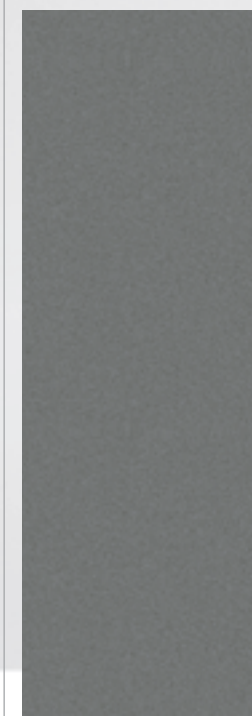
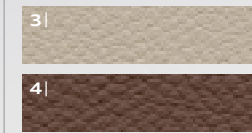

A5 Aruba Blue<sup>‡</sup> PEARL EFFECT<sup>‡</sup>

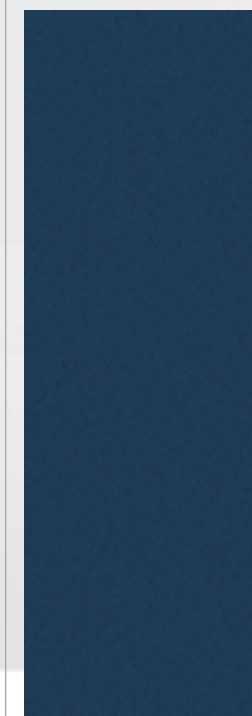
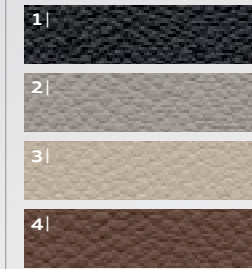

A5 | S5 Ibis White

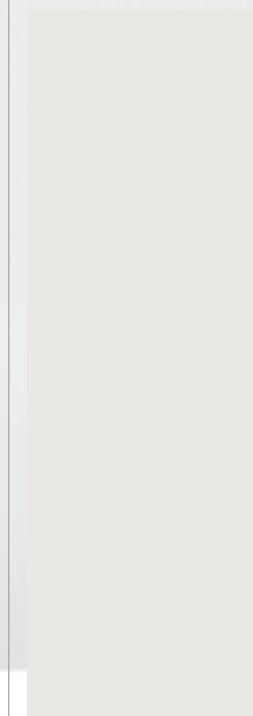
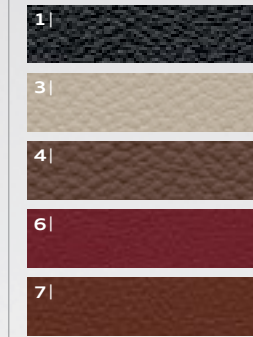

A5 | S5 Brilliant Red

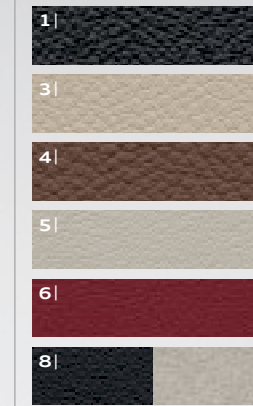

A5 | S5 Ice Silver<sup>1</sup> METALLIC<sup>‡</sup>

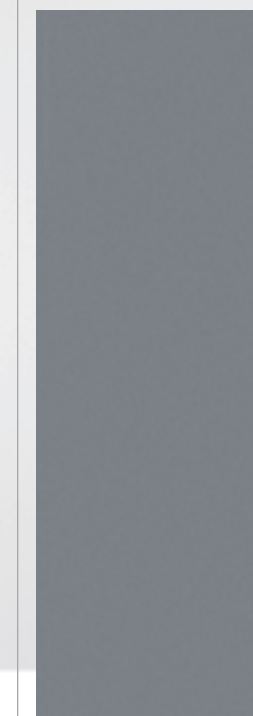
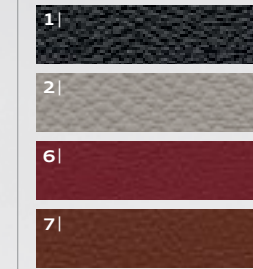

A5 | S5 Brilliant Black

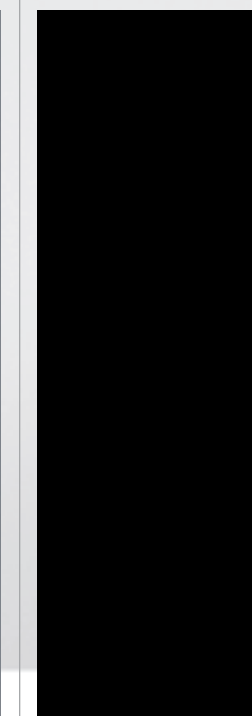
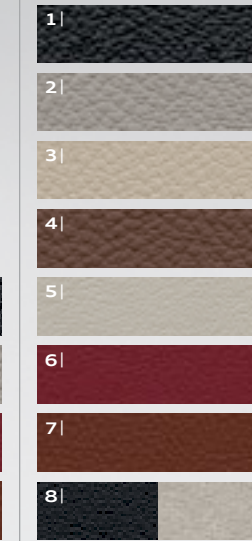

A5 | S5 Quartz Gray<sup>1</sup> METALLIC<sup>‡</sup>

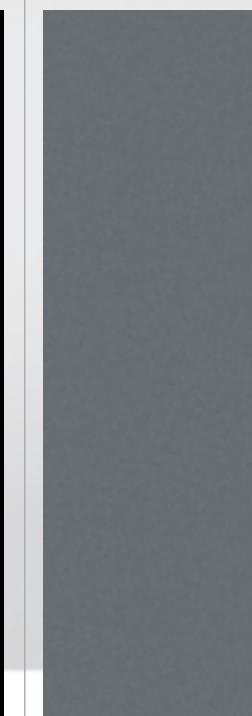
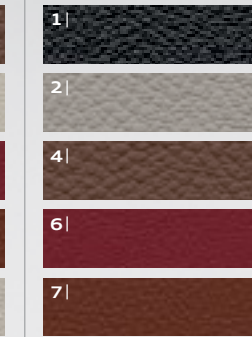

A5 | S5 Deep Sea Blue<sup>‡</sup> PEARL EFFECT<sup>‡</sup>

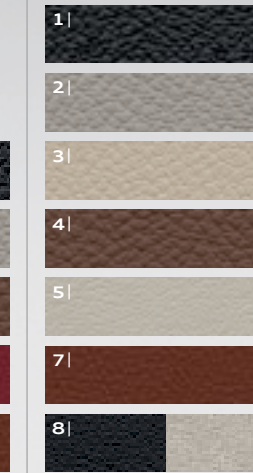

A5 | S5 Meteor Gray<sup>‡</sup> PEARL EFFECT<sup>‡</sup>

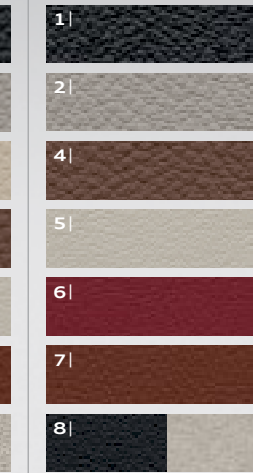

S5 Phantom Black<sup>‡</sup> PEARL EFFECT<sup>‡</sup>

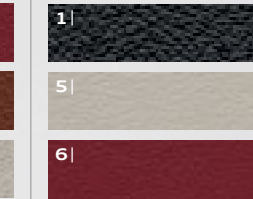

S5 Sprint Blue<sup>‡</sup> PEARL EFFECT<sup>‡</sup>

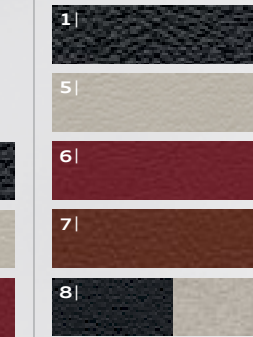

- 1 | Black<sup>‡</sup>
- 2 | Light Gray<sup>‡</sup> [A5 only]
- 3 | Linen Beige<sup>‡</sup> [A5 only]
- 4 | Cinnamon Brown [A5 only]
- 5 | Pearl Silver [S5 only]
- 6 | Magma Red [S5 only]
- 7 | Tuscan Brown [S5 only]
- 8 | Black/Silver Alcantara<sup>‡</sup> [S5 only]

<sup>‡</sup> Available in Milano leather, leather/Perforated Alcantara<sup>®</sup>, Silk Nappa leather and Silk Nappa leather/Alcantara<sup>®</sup>

<sup>‡</sup> Available in leather and Milano leather

<sup>‡</sup> S line only

<sup>‡</sup> Additional charge

Chassis/Technical	A5	S5
Five-link front suspension with upper and lower control arms, stabilizer bar and individual, gas-charged coil springs/shock absorbers	s	s
Independent trapezoidal-link rear suspension with rigid subframe, stabilizer bar and individual, gas-charged coil springs/shock absorbers	s	s
Servotronic® speed-sensitive power steering – varies assistance based on vehicle speed	s	s
quattro® permanent all-wheel drive system utilizing torque-sensing center differential – 40:60 rear-biased torque split	s	s
quattro® with Sport Rear Differential permanent all-wheel drive system utilizing torque-sensing center differential – 40:60 rear-biased torque split and variable torque application between rear wheels	-	o
Sport suspension calibration	o	-
S5 sport suspension calibration	-	s
Six-speed manual transmission	s	s
Tiptronic® automatic transmission	o	o
Fully galvanized steel unibody with multistep anti-corrosion protection	s	s

Safety & Security	A5	S5
Driver and front passenger advanced dual-stage airbag* supplemental restraints	s	s
Driver and front passenger seat-mounted side thorax airbag* supplemental restraints	s	s
Sideguard® head curtain airbags* for both rows of seats	s	s
Front passenger occupant detection for airbag* supplemental restraints	s	s
Front three-point safety belts with automatic pretensioning and force limiters; height adjustable for front seating positions	s	s
Rear three-point safety belts with belt force limiters for outboard passenger seating positions	s	s
Safety belt reminder for driver and front passenger	s	s
Lower Anchors and Tethers for Children [LATCH] in rear seats	s	s
Pinch protection for front windows	s	s
Central locking system with selective unlock feature	s	s
Impact protection – including reinforced high-strength steel/aluminum cross members, reinforced bumpers and rigid occupant cell	s	s
Tire pressure monitoring system	s	s
Electronic Stabilization Program [ESP*]	s	s
Anti-lock Brake System [ABS] with Electronic Brake-pressure Distribution [EBD]	s	s
Brake assist – a system that automatically senses emergency braking and applies maximum power boost to reduce overall stopping distance	s	s
Front ventilated disc brakes	s	s
Rear disc brakes	s	-
Rear ventilated disc brakes	-	s
Audi hill hold assist	s	s
Anti-theft vehicle alarm system with blinking theft-deterrent light	s	s

Features	A5	S5
18" ten-spoke wheels with 245/40 all-season tires	s	-
18" five-spoke wheels with 245/40 all-season tires	o	-
19" five-Y-spoke wheels with 255/35 summer performance tires†	o	-
19" five-double-spoke wheels with 255/35 summer performance tires†	-	s
19" five-tri-spoke wheels with 255/35 summer performance tires†	-	o
Powerful singleframe® grille with choice of front license plate holder or filler panel with two chrome strips	s	s
Chrome trim around exterior windows	s	s
Headlight washers – high-pressure, retractable and heated	-	s
Heated windshield washer nozzles	s	s
Power adjustable and heated side mirrors [Body color on A5]	s	s
Power adjustable, auto-dimming and heated side mirrors with memory function [Body color on A5]	o	o
LED turn signals in mirror housings	s	s
Tilting glass panel Panorama sunroof	s	s
Metallic/pearl effect paint	o	o
Dual exhaust tailpipes [2.0T both on left side; 3.2 one on each side]	s	-
S quad exhaust tailpipes, two left and two right	-	s
Halogen headlights with integrated high and low beams [2.0T Premium only]	s	-
Audi xenon plus headlights with automatic self-leveling and integrated LED daytime running lights	o	s
LED taillights	o	s
Two front fog lights located in lower front bumper	s	s
Automatic light switch controlled by light sensor, "coming home" and "leaving home" functions	o	s
Three blink, touch-to-pass lane change feature in turn signal	s	s
Three-spoke, sport, multifunction, leather-wrapped steering wheel with controls for audio volume, Bluetooth® phone and audio seek functions	s	s
Shift paddles on steering wheel [Automatic transmission]	o	s
Tilt and telescopic manually adjustable steering column	s	s
Interior lights in overhead console with front map lights	s	s
Red ambient LED lighting in headliner for front center console illumination	s	s
Illumination for interior door handles, air vent controls, front footwells	s	s
Front and rear floor mats	s	s
Aluminum Hologram decorative inlays	s	-
Brushed Aluminum decorative inlays	o	s
Genuine wood decorative inlays [Dark Brown Walnut, Almond Beige Ash, Nutmeg Laurel]	o	-
Genuine wood decorative inlays [Gray Birch]	-	o
Carbon Fiber decorative inlays	-	o
Stainless Steel texture decorative inlays	-	o
Aluminum doorsill inlays	s	s

Features	A5	S5
Folding front center armrest with adjustable height	s	s
Storage nets in back of front seats	s	s
Power central locking system with radio-operated key fob remote control for doors, deck lid and fuel door	s	s
Audi advanced key – keyless start, stop, and entry	o	o
Automatic climate control	s	-
Three-zone automatic climate control	o	s
Power windows with one-touch up/down operation and pinch-protection	s	s
Electronic cruise control	s	s
Adaptive cruise control – maintains preset distance from vehicle in front	o	o
Electric rear window defogger with automatic timed shutoff feature	s	s
Interior trunk release on driver's door	s	s
Dual front sun visors with lighted vanity mirror for driver and front passenger	s	s
Twelve-volt accessory power outlet in front center console	s	s
Two assist handles in headliner above each door with slow retraction feature	s	s
Removable cargo floor for access to spare	s	s
Leather seating surfaces	s	-
Genuine Milano leather seats	o	-
Silk Nappa leather upholstery	-	s
Silk Nappa leather with Alcantara® inserts	-	o
Eight-way power driver seat with four-way power lumbar adjustment	s	s
Eight-way power passenger seat	s	-
Memory for driver seat adjustment and exterior mirrors	o	o
Eight-way power sport front seats with four-way power lumbar adjustment	o	-
Eight-way power S5 sport front seats with integrated headrests and four-way power lumbar adjustment	-	s
Six-step heated front seats	o	s
Split folding 50/50 rear seatback	s	s
Dual rear cup holders	s	s
Two front cup holders	s	s
Tool kit located in storage compartment in trunk	s	s
Glove box in front passenger's side of dash panel	s	s
Auto-dimming interior mirror with digital compass	o	o
Audi concert system with single CD player [MP3 capable], AM/FM radio, auxiliary input jack, SD* card slot for MP3 files, and speed-dependent volume control	s	s
SIRIUS® Satellite Radio with three month trial subscription	s	s
Audi Navigation plus† with 3rd generation MMI†, hard-drive navigation, one DVD player, AM/FM radio, two SD* card slots for MP3 files, and SIRIUS® Satellite Radio	o	o
Audi music interface with iPod® integration	o	s
Audi Sound System, 180 watts with ten speakers, including a subwoofer and center fill speaker	s	s
Bang & Olufsen® Sound System–505 watt audio system with 14 speakers and ten-channel amplifier	o	o

Features	A5	S5
Bluetooth® preparation for mobile phone	o	s
Voice control for navigation, audio functions and telephone	o	o
Rear parking sensors with rearview camera	o	o
HomeLink® remote transmitter	o	s
Backlit electro-luminescent instrument cluster with brightness control	s	s
Digital trip odometer with service interval indicator	s	s
Driver information system – trip computer, outside temperature, radio/telephone/navigation display, auto-check, open door/deck lid indicator	s	s
Windshield wipers with four-position lever [includes interval wiping]	s	s
Rain sensor for automatic windshield wipers	o	o

Packages	A5	S5
19" Sport Package: 19" alloy wheels with summer performance tires†, sport seats, lumbar control for driver and passenger, sport suspension and shift paddles on automatic transmission models	o	-
Driver Assist Package: Audi side assist, rear parking sensors with rearview camera	o	o
S line Package: S line front/rear bumpers, rocker moldings, badge on fenders, 19" alloy wheels with summer performance tires†, sport seats, lumbar control for driver and passenger, sport suspension, shift paddles on automatic transmission models, leather and perforated Alcantara® S line upholstery and Brushed Aluminum inlays	o	-
A5 Audi Drive Select Package: Dynamic steering system, dynamic suspension system, dynamic engine/transmission settings, Audi drive select controls	o	-
S5 Audi Drive Select Package: Dynamic steering system, dynamic suspension system, dynamic engine/transmission settings, Audi drive select controls, quattro® with Sport Rear Differential	-	o
quattro® with Sport Rear Differential Package: Audi drive select controls, Sport Rear Differential	-	o

-	Not Available	o	Option	s	Standard
---	---------------	---	--------	---	----------

The table above represents the standard equipment on the Premium model. Many popular options are combined and available on the Premium Plus and Prestige models. Please see the package contents in this brochure for complete details.

\* Airbags are supplemental restraints only and will not deploy under all crash circumstances. Always use safety belts and seat children in the rear, using restraint systems appropriate for their size and age.  
† Summer performance tires are designed for optimum performance and handling in warm climates. They are not suitable for cold, snowy or icy weather conditions. If you drive under those circumstances, you should equip your vehicle with all-season or winter tires, which offer better traction under those conditions. We suggest you use the recommended winter or all-season tires specified for your car or their equivalent. These summer performance tires also have a lower aspect ratio that aids performance and handling; however, in order to avoid tire, rim or vehicle damage, it is important that the inflation pressure is regularly checked and maintained at recommended levels. Serious wheel and tire damage may occur if the vehicle is operated on rough or damaged road surfaces, or upon encountering road debris or obstacles. Please also remember in making your selection that, while these tires deliver responsive handling, they may ride less comfortably and make more noise than other choices. Finally, these tires may wear more quickly than other choices. For more information on all of these topics, please consult the owner's manual, your local dealer or call 1-800-FOR-AUDI.  
‡ Audi Navigation plus depends on signals from the worldwide Global Positioning Satellite network. The vehicle's electrical system, and existing wireless and satellite technologies, must be available and operating properly for the system to function. The system is designed to provide you with suggested routes in locating addresses, destination and other points of interest. Changes in street names, construction zones, traffic flow, points of interest and other road system changes are beyond the control of Audi of America, Inc. Complete detailed mapping of lanes, roads, streets, toll roads, highways, etc., is not possible, therefore you may encounter discrepancies between the mapping and your actual location. Please rely on your individual judgement in determining whether or not to follow a suggested Audi Navigation plus route. Periodically, the mapping is updated, and a new DVD will be required in order to maintain the latest navigation information available to us. These will be available for purchase from time to time at an additional cost. Consult your dealer or call 1-800-FOR-AUDI for details.  
§ Your Audi vehicle is equipped with a phone preparation utilizing Bluetooth® interface to enable hands-free functionality [compatible mobile phones sold separately]. You will need a Bluetooth®-enabled mobile phone in order to utilize this function. Not all Bluetooth®-enabled mobile phone models are compatible with Audi phone preparation. Visit audiusa.com/bluetooth, or contact your local Audi dealer for the latest listing of compatible phones. Audi recommends use of the Audi phone cradle [sold separately] with your mobile phone while operating this vehicle.



### A5 Model Configurations

- 2.0 TFSI® with six-speed manual transmission and quattro® all-wheel drive
- 2.0 TFSI® with six-speed Tiptronic® transmission and quattro® all-wheel drive

#### Power and Performance

- + 2.0 liter turbocharged, DOHC in-line four-cylinder gasoline engine with FSI® direct injection, variable valve timing and Audi valvelift system
- + Displacement: 2.0 liters [121.1 cu. in.]
- + Bore: 3.25 in. Stroke: 3.65 in. Compression ratio: 9.6:1
- + Horsepower: 211 hp @ 4300-6000 rpm Torque: 258 lb-ft. @ 1500-4200 rpm
- + 0-60 MPH in seconds – Manual: 6.5, Tiptronic®: 6.7
- + Top track speed<sup>§</sup>: 130 MPH
- + Fuel economy estimate, city/highway<sup>\*</sup>: N/A

### A5 Model Configurations

- 3.2 FSI® with six-speed Tiptronic® transmission and quattro® all-wheel drive

#### Power and Performance

- + 3.2 liter DOHC V6 gasoline engine with FSI® direct injection, variable valve timing and Audi valvelift system
- + Displacement: 3.2 liters [195.1 cu. in.]
- + Bore: 3.37 in. Stroke: 3.65 in. Compression ratio: 12.5:1
- + Horsepower: 265 hp @ 6500 rpm Torque: 243 lb-ft. @ 6500 rpm
- + 0-60 MPH in seconds: 5.8
- + Top track speed<sup>§</sup>: 130 MPH
- + Fuel economy estimate, city/highway<sup>\*</sup>: 17/26 MPG

### S5 Model Configurations

- 4.2 FSI® with six-speed manual transmission and quattro® all-wheel drive
- 4.2 FSI® with six-speed Tiptronic® transmission and quattro® all-wheel drive

#### Power and Performance

- + 4.2 liter DOHC V8 gasoline engine with FSI® direct injection, variable valve timing and intake manifold
- + Displacement: 4.2 liters [256.3 cu. in.]
- + Bore: 3.33 in. Stroke: 3.65 in. Compression ratio: 11.0:1
- + Horsepower: 354 hp @ 6800 rpm Torque: 325 lb-ft. @ 3500 rpm
- + 0-60 MPH in seconds: 4.9
- + Top track speed<sup>§</sup>: 155 MPH
- + Fuel economy estimate, city/highway<sup>\*</sup>: S5 six-speed manual: 14/22 MPG  
S5 six-speed Tiptronic®: 16/24 MPG



### A5

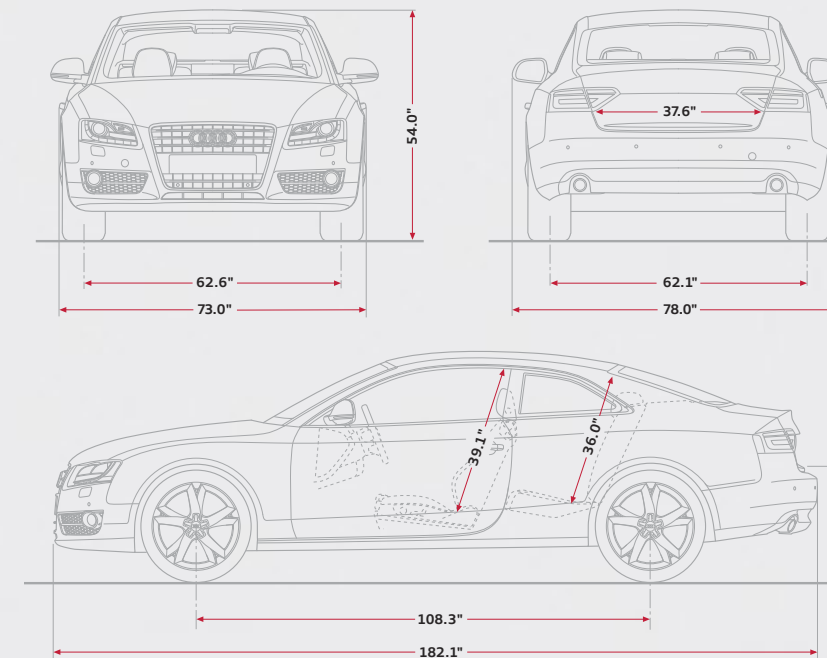

### S5

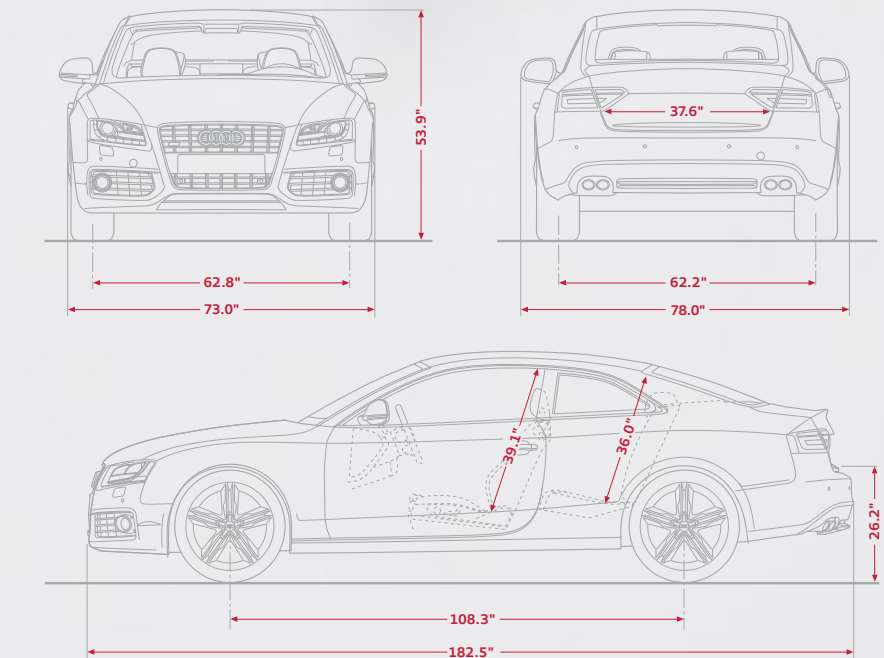

\* Top track speed for A5 electronically limited to 130 MPH in the U.S. Obey all local speed and traffic laws. \* EPA fuel economy estimate not available at the time of printing. \* EPA fuel economy estimates. Your mileage will vary. § Top track speed electronically limited to 155 MPH in the U.S. Obey all local speed and traffic laws.

**With so much to offer, there is only one place  
where you can experience it all.**

To fully interact with Audi, visit us online at any number of our special sites. From configuring your next Audi, to learning about the latest technology, to experiencing our passion for performance and racing, we invite you to explore the rich, stimulating world that is uniquely Audi.



[audiusa.com/a5](http://audiusa.com/a5)



#### Model Specific Info Summary

Dive into detailed information on the model you are considering. Each model in the Audi lineup has dedicated pages providing information on technical specifications, design, performance, safety and technology features, as well as extensive multimedia galleries.

[audiusa.com/models](http://audiusa.com/models)



#### See All Models

Select from a remarkable array of engines, exterior colors, interior materials and progressive options to assemble your own unique Audi. You can print, request a quote or take your document to the nearest Audi dealer.

[audiusa.com/technology](http://audiusa.com/technology)



#### Technology Microsite

From the very beginning, advanced technology has been at the very heart of the Audi DNA. Contained in one convenient location, you will find great detail and demonstrations of many of our technologies.

[audidrivingsite.com](http://audidrivingsite.com)



#### Audi Driving Experience

The Audi driving experience and the Audi sportscar experience are designed to not only offer you a very special track experience in an Audi, but one that will leave you with a genuine appreciation for the technology that goes into every Audi vehicle.

[audiusa.com/experience](http://audiusa.com/experience)



#### Audi Experience

The experience section is your starting place for everything Audi. From an in-depth brand experience to a journey of our rich motorsports heritage or exclusive downloads, the online Audi Experience accommodates it all.

[audi-collection.com](http://audi-collection.com)



#### Audi Collection

Beautifully made. Beautifully designed. Faultlessly functional. All the qualities that distinguish our cars can also be found in our Audi collection. From performance wheels to products designed specifically with you and your particular Audi in mind to enhance the pleasure of driving and owning an Audi.



## Four driven wheels are a part of what drives our progress.

Nearly 30 years ago, the notion of a car with permanent four-wheel drive was revolutionary. Audi called it quattro® and its benefits would set a new benchmark for driver confidence and performance. The simple, yet profound result of sending power to all wheels means that snow-covered mountain passes, rain-slicked highways and gravel-strewn rural roads are no longer encountered with apprehension. While on smooth dry roads, quattro® offers a level of performance unachievable by two-wheel drive cars.

The advantage of all-wheel drive was most apparent when Audi introduced quattro® to the World Rally Championship. quattro® seemed to defy physics with startling acceleration and remarkable traction. The result was an astounding 24 wins and a number of World Championships. If that wasn't enough of an endorsement for quattro®, it was later deemed an "unfair advantage" and banned from road racing altogether after repeatedly dominating the field.

Today, in that same competitive spirit, quattro® all-wheel drive continues to be refined. In Audi vehicles with a longitudinal engine configuration, quattro® is essentially a mechanical system with a self-locking center differential and continuously variable torque distribution. quattro® instantly responds to wheel speed differences and dynamically adjusts power to the wheels with the best traction. It is supported by advanced electronic control systems that together offer numerous benefits over other all-wheel drive systems. Featuring a 40:60 rear torque bias, the latest version of quattro® offers sportscar-like performance and handling with uncompromised all-wheel drive traction.

The power of quattro® is its ability to inspire driver confidence,  
giving you traction when you need it, where you need it, regardless of road conditions.

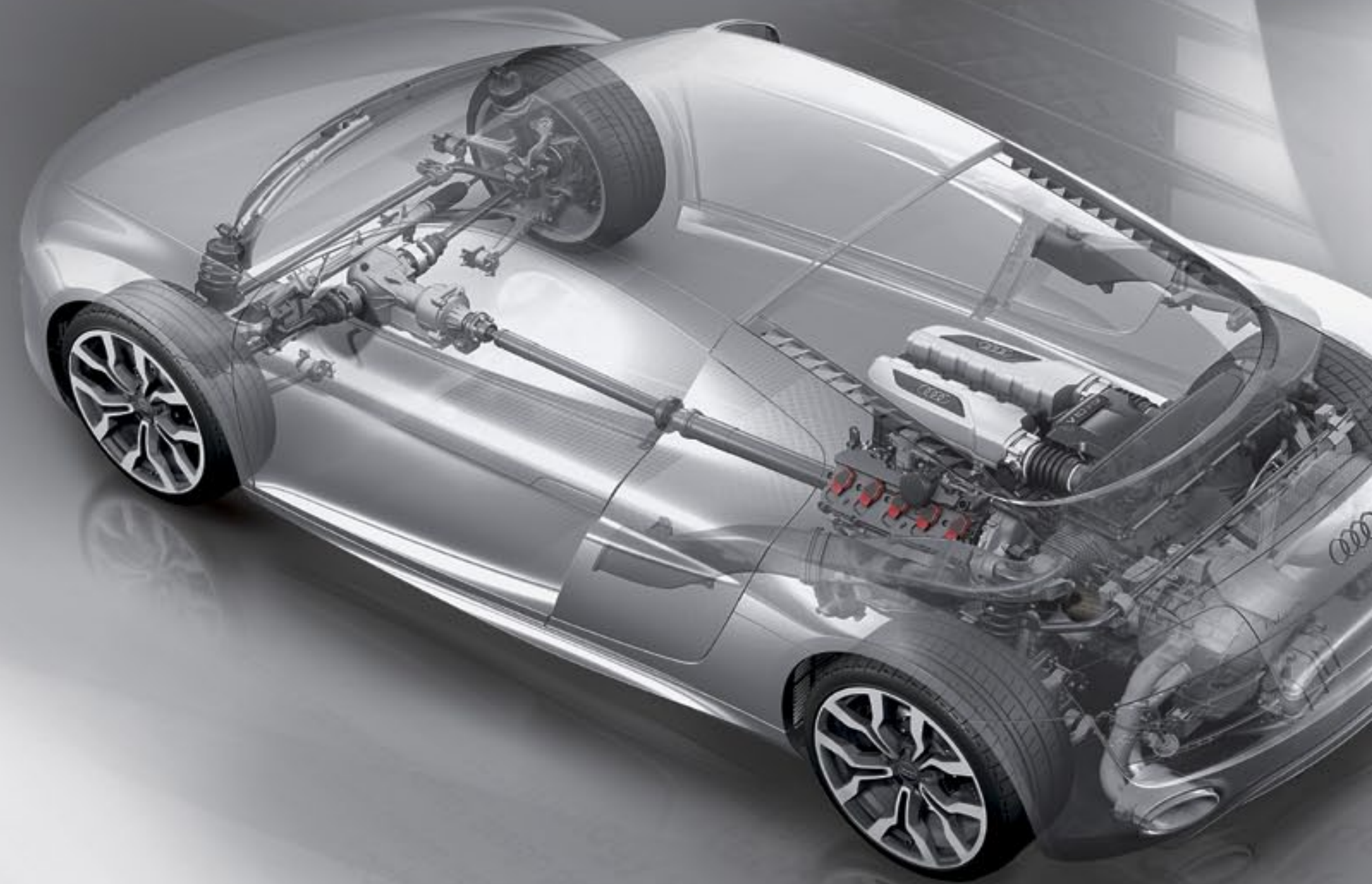



## Together the future is ours.

August Horch founded this company on one word: **Progress**. Back in 1909.

To us, it is taking what seems undoable and then doing it. It is discovering what no one else has bothered to discover. It is turning skeptics into believers, and it is taking the thinking that wins on the racetrack and putting it on the road. Relentlessly designing, innovating, engineering and racing for the past 100 years have yielded amazing progress in our quest for the Truth. And although the Truth is absolute, it's in a constant state of motion always revealing new limits and opportunities. For instance, what seemed improbable has become the standard as we have created a diesel engine so quiet, so clean, so efficient and so powerful we put it to the ultimate test competing in the 24 Hours of Le Mans... winning three years in a row. But aside from walking away with trophies, we walked away with a deeper understanding of what to engineer into our cars for the street. The remarkable capabilities of TDI® clean diesel power, the all-wheel drive confidence of quattro®, and the increased power and efficiency of FSI® are but a few of those strands of DNA that have brought us that much closer to the Truth.

And it is that quest for the Truth that is behind every pencil line we draw, every calculation we make and every idea we deem not good enough. And although they may prove to be remarkable achievements in their own right, they represent a greater commitment to what is most important: **Truth in Engineering**.

**Note:** A word about this brochure. Audi of America, Inc. believes the specifications in this brochure to be correct at the time of printing. However, specifications, standard equipment, options and colors are subject to change without notice. Some equipment may be unavailable when your vehicle is built. Please ask your dealer for advice concerning current availability of standard and optional equipment and your dealer will verify that your vehicle includes the equipment you ordered. Vehicles in this brochure are shown with optional equipment. See your dealer for complete details on the new-vehicle limited warranty, twelve-year limited warranty against corrosion perforation and Audi 24/7 Roadside Assistance. [Roadside assistance coverage provided by Road America in the U.S. Certain conditions apply, see your dealer for details.] Tires supplied by various manufacturers. "Truth in Engineering" is a trademark of Audi of America, Inc. "Audi," "quattro," "singleframe," "A5," "S5," "MMI," "FSI," "TFSI," "Sideguard" and the four rings logo are registered trademarks of AUDI AG. "Servotronic" is a registered trademark of the AM General Corporation. "Tiptronic" is a registered trademark of Dr. Ing h.c. F. Porsche AG. "Alcantara" is a registered trademark of Alcantara S.P.A. "Bang & Olufsen" is a registered trademark of the Bang & Olufsen Group. "NVIDIA" is a registered trademark of NVIDIA Corporation. "Barracuda" is a registered trademark of Mont Blanc. "Stormshield" is a registered trademark of Guilford Mills Inc. "ESP" is a registered trademark of Daimler AG. "HomeLink" is a registered trademark of Prince Corporation, Holland, Michigan. Prince is a wholly owned subsidiary of Johnson Controls. "SIRIUS" is a registered trademark of SIRIUS Satellite Radio, Inc. "SD" is a registered trademark of SD-3C, LLC. "Bluetooth" is a registered trademark of Bluetooth SIG, Inc. "iPod" is a registered trademark of Apple, Inc.

©2009 Audi of America, Inc.