



Audi of America

Audi A5 coupe 2.0 TFSI Technical Specifications

2011 Model Year

Technical Specifications		2011 Audi A5 coupe 2.0 TFSI	
ENGINE:			
Type	Inline four-cylinder gasoline engine with FSI direct injection, exhaust turbocharger with intercooler, four valves per cylinder.		
Arrangement	Front mounted, longitudinal		
Bore	3.25 in.	82.5 mm	
Stroke	3.65 in.	92.8 mm	
Displacement	121.1 cu. in.	1984 cc	
Compression ratio	9.6:1		
Fuel requirement	Premium unleaded (91 Octane) recommended for maximum performance		
Horsepower (SAE)	211 hp	@ 4300-6000 rpm	
Max. Torque	258 lbs. ft.	@ 1500-4200 rpm	
ENGINE DESIGN:			
Cylinder block	cast iron		
Cylinder head	aluminum alloy		
Valve train / intake	Audi valvelift system on exhaust valves, DOHC, chain driven, hydraulic lifters		
Firing order	1-3-4-2		
Fuel injection	Electronic engine management, drive-by-wire throttle, FSI direct injection		
Emission system	Close-coupled ceramic catalytic converter		
Emissions level	EU5; ULEVII		
ELECTRICAL SYSTEM:			
Battery	12 volts	60 amp/hr	
Alternator	14 volts	140 amp	
DRIVETRAIN:			
Transmission	Automatic: Tiptronic 6-speed automatic Manual: 6-speed manual transmission		
Type	Tiptronic automatic (quattro AWD)		6-sp manual trans (quattro AWD)
	Automatic		Manual
Gear ratios:	1st	4.171	3.778
	2nd	2.340	2.050
	3rd	1.521	1.321
	4th	1.143	0.970
	5th	0.867	0.811
	6th	0.691	0.682
	reverse	3.403	3.333
	Final Drive	3.517	3.693
Front Differential	electronically locking (EDL)		
Center Differential (for quattro)	self-locking center differential		
Rear Differential (for quattro)	electronically locking (EDL)		
STEERING:			
Type	Servotronic vehicle speed-sensitive hydraulic power assist		
Ratio	16.3:1		
Turning circle (curb-to-curb)	37.4 ft.	11.4 m	
SUSPENSION:			
Front	Five-link front suspension, upper and lower wishbones, tubular anti-roll bar		
Rear	Independent trapezoidal link with resiliently mounted subframe, anti-roll bar		
BRAKES:			
System	Dual-circuit brake system with diagonal split, Anti-lock Brake System (ABS), Electronic Brake pressure Distribution (EBD) and Electronic Stabilization Program (ESP); tandem brake booster		
Front	Ventilated discs		
Rear	Solid discs		
Parking brake	Electromechanical, actuated at rear wheels		

Audi of America

Audi A5 coupe 2.0 TFSI Technical Specifications

2011 Model Year

Technical Specifications (continued)		2011 Audi A5 coupe 2.0 TFSI			
WHEELS:					
Size	8.5X18 alloy	standard			
	8.5X19 alloy	optional			
TIRES:					
Size	245/40 R18 all season	standard			
	255/35 R19 summer performance	optional			
BODY:					
Material	Unitized steel structure				
Corrosion protection	All steel parts are 100% dual-side zinc-galvanized (12 year limited warranty against corrosion perforation)				
WARRANTY/MAINTENANCE:					
	4-Year/50,000 mile new vehicle limited warranty				
	12-Month/5,000 mile (whichever occurs first)				
CAPACITIES:					
Engine oil	4.8576 qt.	4.6 liter			
Fuel tank	16.896 gal.	64 liter			
Cooling system	8.2368 qt.	7.8 liter			
EXTERIOR DIMENSIONS:					
Wheelbase	108.31 in.	2751 mm			
Track: front / rear	62.5/62.09	1590/1577			
Overall length	182.09 in.	4625 mm			
Overall width incl. mirrors	79.527 in.	2020 mm			
Height (unloaded)	54.016 in.	1372 mm			
Ground clearance (loaded)	n/a in.	n/a mm			
	quattro Manual Trans		quattro Tiptronic Trans		
Curb weight	3583	lbs	3682	lbs	
Drag coefficient	Cw = 0.296 Frontal Area = = 2.17 sq. m.				
INTERIOR DIMENSIONS:					
EPA Class	Subcompact cars				
Seating Capacity	4				
Head room front / rear	39.094 in.	993 mm	/	36.0 in.	914 mm
Leg room front / rear	41.34 in.		/	31.7 in.	
Shoulder room front / rear	54.252 in.	1378 mm	/	52.8 in.	1342 mm
Int. vol. (EPA)	84 cu. ft.				
Luggage capacity (EPA)	12.2 cu. ft.				
PERFORMANCE:					
	quattro Manual Trans		quattro Tiptronic Trans		
0-60 mph	6.4	sec.	6.7	sec.	
Top speed	Electronically limited to 130 mph				
FUEL ECONOMY:					
	2011 MY EPA				
	quattro Manual Trans		quattro Tiptronic Trans		
City	21	mpg	21	mpg	
Highway	31	mpg	29	mpg	
Combined	25	mpg	24	mpg	

Audi A5



Dimensions
03/07

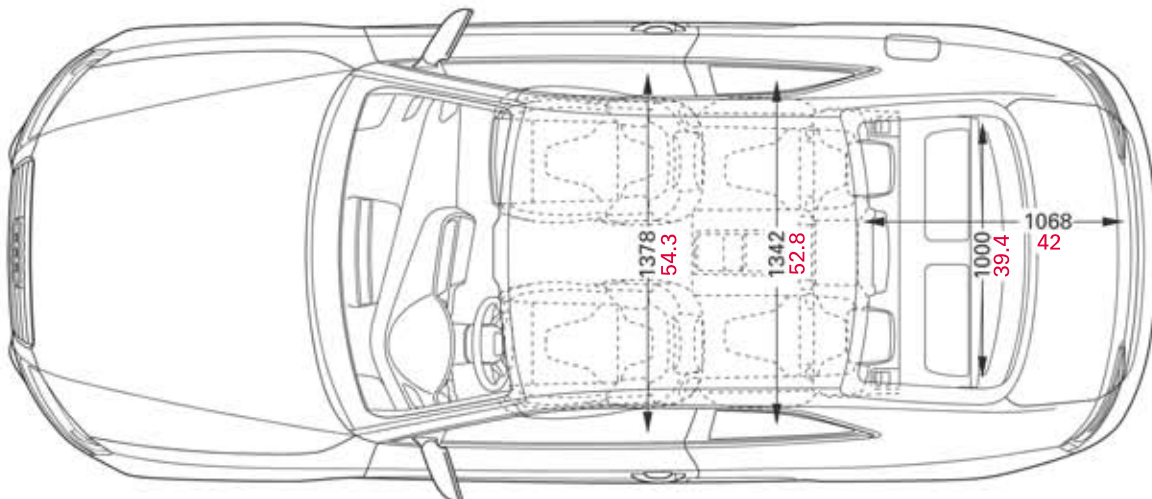
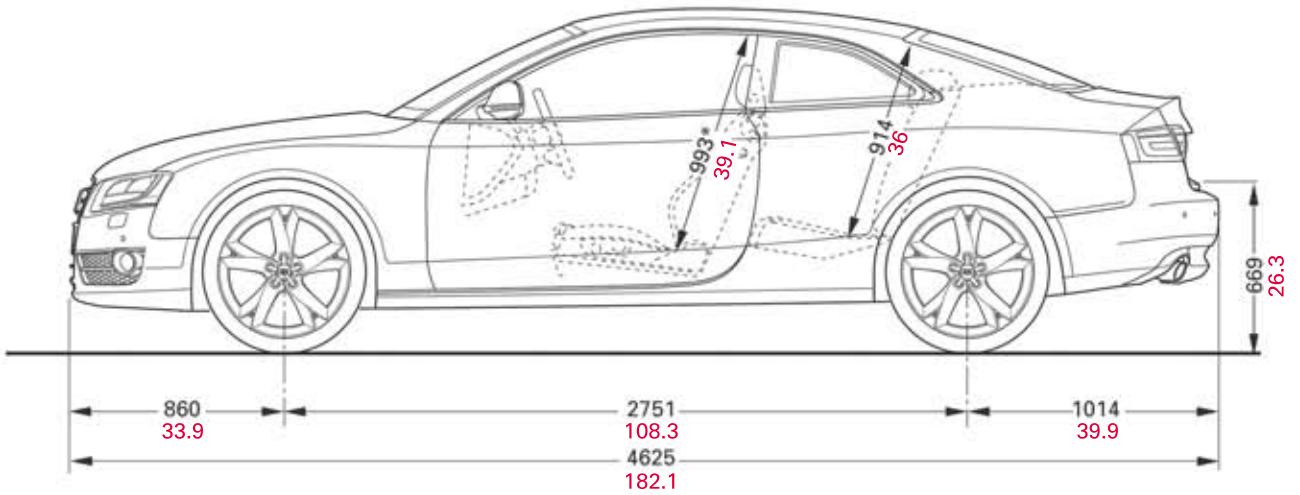
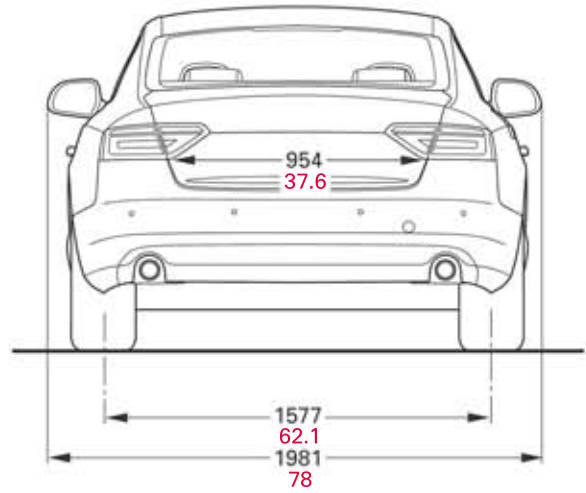
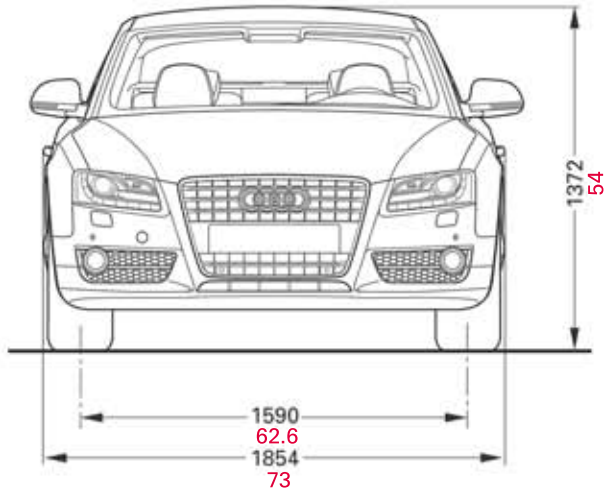

* maximum headroom
Dimensions in millimeters and inches
Dimensions of vehicle unloaded